

Technical Specification Sheet

BEST 475 K+

1.5 bowl granite sink with drainer



Specification

Material	Granite
Finish	Keratek
Colours	Black / Light Grey / White
No. of bowls	1.5
Fitting Method	Inset Only
Handing Options	Reversible
Cabinet Size (mm)	600
Overall Length (mm)	1000
Overall Width (mm)	510
Main Bowl Length (mm)	299
Main Bowl Width (mm)	421
Main Bowl Depth (mm)	200
Second Bowl Length (mm)	149
Second Bowl Width (mm)	421
Second Bowl Depth (mm)	140
Tap Hole Size (mm)	35 (Pre-drilled under sink)
Tap Hole Instructions	Drill out using diamond core drill piece
Waste Kit Included (Yes/No)	Yes
Clips & Seals Included (Yes/No)	Yes
Waste Size (mm)	90
Waste Kit Code	
Clips & Seals Code	N/A
Overflow Location	In main bowl
Cut Out Length (mm)	980
Cut Out Width (mm)	480
Product Weight (kg)	19.4
Packed Weight (kg)	22
Packed Dimensions (mm)	1080 x 590 x 340

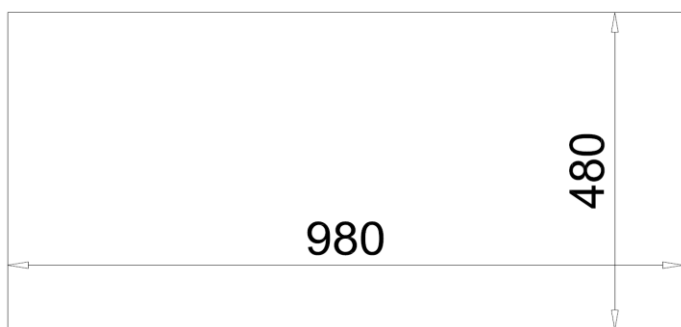
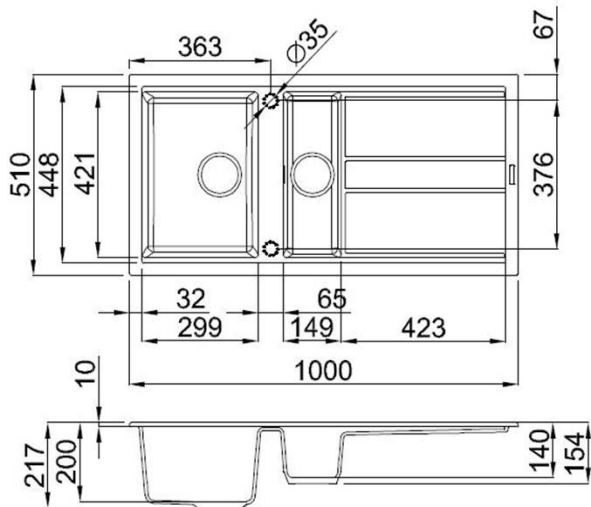

Warranty

10 Year warranty on the sink only | Serviceable Parts/waste kit etc is 1 year

Care & Maintenance

Use warm soapy water to clean/maintain sink | Elleci Daily Clean spray & Antiscale products are available for deeper cleans | Never use any abrasive chemicals/cleaning products on the surface of the sink as this will invalidate the warranty if used.