

Condens 7000 WP

Technical and specification guide

Quick installation, easy maintenance



5
Year
Guarantee*



Contents

Product overview	4	Typical use cases	31
Features and benefits	5	Single boiler application	31
Technical data	6	Cascade application	33
Installing a cascade	7		
Product breakdown	8	Getting started	34
The inside story	8	Registration / commissioning	34
Specification considerations	12	Packs and part numbers	35
Space requirements	12	Single boiler packs	35
Water system connections	16	Cascade boiler packs	36
Controls	19	Accessories	38
Flues and ventilation	24		



Training Courses

Our commercial trainers have many year's experience as technical heating technicians and deliver first-class training across a wide range of products, including the Bosch Condens 7000 WP.

To book onto one of our Bosch Condens 7000 WP training courses:



Email
training@uk.bosch.com



Visit our eAcademy
worcesterbosch-academy.co.uk

Why install the Condens 7000 WP?



Guaranteed
5 years peace of mind for you and your customers*



Quick installation
Rapid installation thanks to our new frame kit design



Efficient
Automatic modulation to match heat demand



Easy maintenance
Components accessible from the front



Connected
Touch-screen display for faster commissioning and fault-finding



High output
Outputs from 50kW up to 145kW with the ability to cascade up to 860kW

Product overview

Available in outputs of 50kW, 65kW, 85kW, 100kW, 125kW and 145kW. The Condens 7000 WP can be cascaded in banks of up to 6 boilers per bank providing up to 858.6kW at 50/30 per bank.

Applications

Our Condens 7000 WP is a wall-hung boiler suitable for large domestic properties, multi-family housing and commercial installations. It can also be used in combination with high output heat pumps to create a flexible hybrid solution.

Output flexibility and compact size

An ideal choice for applications where space is restricted but there is a demand for a modern high output, high efficiency heating solution. Control strategies can provide cascade and sequencing for up to 16 boilers at a time for up to 2.2MW of power.

High efficiency, low emissions

Our Condens 7000 WP boosts seasonal efficiencies of up to 96.5% using the much loved ALU plus heat exchanger with class 6 levels of NOx as low as 25mg/kWh @ 0% O2.**

Hydrogen blend ready

Our entire gas boiler range is able to run on a 20% hydrogen blend – so your customer can be confident it will run on gas for its lifetime.

Precise energy management

Each boiler can automatically modulate its output to precisely match the heat demand, reducing fuel consumption and improving overall seasonal efficiency.

With cascades, modulation is from the lowest output of the smallest boiler up to the total load of all the boilers. The 50-100kW products can modulate at a ratio of 1:5 and both the 125kW and 145kW boilers modulate at 1:6.

Time and cost saving

The boiler's small footprint increases installation flexibility, speeds up installation time and improves access for servicing and maintenance, reducing the need to have larger boiler rooms to achieve higher system outputs.

Patented ALU-Plus heat exchanger



The maintenance-reducing heat exchanger is lightweight, robust and allows for a rapid transfer of heat. Combined with its fully insulated case, the boiler is especially quiet in the industry, with our 50kW model being Quiet Mark certified.



*Quiet Mark certification applicable to the Condens 7000 WP 50kW single boiler.
**Applicable to GC7000 WP 50kW model variant only. Please refer to technical data table on page 6.

Features and benefits



-  **Eye-level control** – for easier commissioning
-  **Innovative control display** – simple, self-explanatory menu guidance with colour display and touch buttons
-  **C8 heat exchanger** – continuously optimised over the past 15 years
-  **Front cover** – easy to remove with just one click
-  **Electrical connection** – easily accessible from the top with reliefs for secure cables, MM100 module can be installed
-  **Exhaust gas connection** – 100/160 as standard, rotatable by 360°, flue gas measuring points integrated
-  **Everything is ready** – PWM cable connection for the pump group for easy connection
-  **Easy to assemble** – simple and safe handling thanks to ergonomic handle design

Additional features and benefits

- ▶ Condensing technology with up to 108.7% net efficiency – saves fuel compared to a standard efficiency boiler
- ▶ Modulation to just 20% of total output* – year round efficiency according to seasonal demand
- ▶ Cascade frame kits can be combined with site made hydraulic arrangements
- ▶ Low emission levels – cleaner combustion and increased carbon savings
- ▶ Expect to save up to 60% on the average installation time compared to GB162 V2**
- ▶ Integrates with solar thermal installations – maximise savings from solar hot water
- ▶ Individual lift weight only 74kg for 50–100 models†
- ▶ Easy manoeuvrability with built-in handles
- ▶ Flexible control options, including Control 8000, Sense II and BMS System – increased system functionality and reduced running costs
- ▶ LPG conversion available – suitable for off mains locations.

*Modulation range will vary depending on model and system operating temperatures.
**Time savings estimated and observed during customer installation studies.
†Ensure safe lifting methods and sufficient people appropriate for the weight to be lifted.

Technical data

Condens 7000 WP		Unit	50 kW	65 kW	85 kW	100 kW	125 kW	145 kW	
Nominal heat output @ 80/60 °C		kW	13.0 – 46.5	13.0 – 62.6	18.9 – 80.0	19.0 – 94.5	24.1 – 116.9	24.1 – 138.8	
Nominal heat output @ 50/30 °C		kW	14.3 – 49.9	14.3 – 69.5	20.8 – 84.5	20.8 – 99.5	26.2 – 124.4	26.2 – 143.1	
Rated heat input		kW	13.3 – 47.5	13.3 – 64.3	19.3 – 82.0	19.3 – 96.5	24.5 – 118.1	24.5 – 140.1	
Net efficiency (partial load 30% in accordance with EN15502)		%	108.4	108.7	109.1	108.7	109.3	109.6	
Seasonal efficiency (as L2B)		%	96	96.3	96.5	96.2	96.7	97	
ErP class and seasonal efficiency		%	A / 93			N/A			
Standby loss (in accordance with EN15502)		%	0.24	0.18	0.14	0.12	0.12	0.15	
Maximum working pressure		bar	6 *						
Maximum flow temperature		°C	85						
Maximum flow rate @ ΔT=20k		l/h	5000			7000			
Required flow rate @ ΔT=20k		l/h	2200	3000	3600	4300	5300	6300	
Resistance @ required flow rate (boiler only)		mbar	75	130	170	240	312	430	
Maximum condensate rate		l/h	6	7.6	9.3	11	13.5	16.0	
Noise level @ 1m Full load		dB(A)	55	61	61 **	64 **	65**	69**	
Fuel type		Natural gas H (G20) – LPG (G31)							
Gas category according to EN 437		GB/IE II2H,3P 20;37mbar							
Gas pressure – min/max		mbar	Natural gas 17/25 – LPG 25/45						
Gas rating – natural gas (G20)		m³/h	5.03	6.8	8.68	10.21	12.63	15.14	
Gas rating – LPG (G31)		m³/h	1.94	2.62	3.34	3.93	4.86	5.83	
CO ² content – NG (G20)		%	Full load	9.3	9.3	9.1	9.1	8.8	8.7
			Part load	8.4	8.4	8.2	8.1	8.3	8.3
CO ² emission G20		Full load	ppm	31	63	70	81	76	85
NOx emission G20 @ full load (in accordance with EN15502)		mg/kWh	25	34	34	38	35	38	
Residual head of fan		Pa	71	130	162	226	145	200	
Flue gas mass flow rate		Full load	g/s	21.6	29.2	38	44.7	56.3	67.5
Flue gas temperature @ 80/60 °C		°C	Part load	56	56	56	56	56	56
			Full load	59	62	66	72	67	71
Flue gas temperature @ 50/30 °C		°C	Part load	32	32	34	34		
			Full load	39	43	50	53	50	53
Flue type		B23, B53, C13, C33, C43, C53, C63, C83, C93							
Mains connection voltage / phase		V	230 / single phase						
Power supply rating		230 VAC, 50 Hz, 130 Watts							
Electrical ingress protection		IPX0D							
Electrical power consumption (without pump group)		tW	Standby	2	2	2	2	2	2
			Part load	8	8	12	12	15	15
			Full load	31	65	88	133	145	243

*Standard 3 bar safety valve for 50kW to 100kW pump group and 4 bar safety valve for 125kW & 145kW. 4 & 6 bar safety valves available as accessory.
 **Noise level for 85, 100, 125 & 145 kW are indicative values.

Installing a cascade

Our brand new installation concept allows you to install the boiler in less than half the time of its predecessor, the GB162 V2*. Building from the ground up allows you to quickly and efficiently install the Condens 7000 WP.

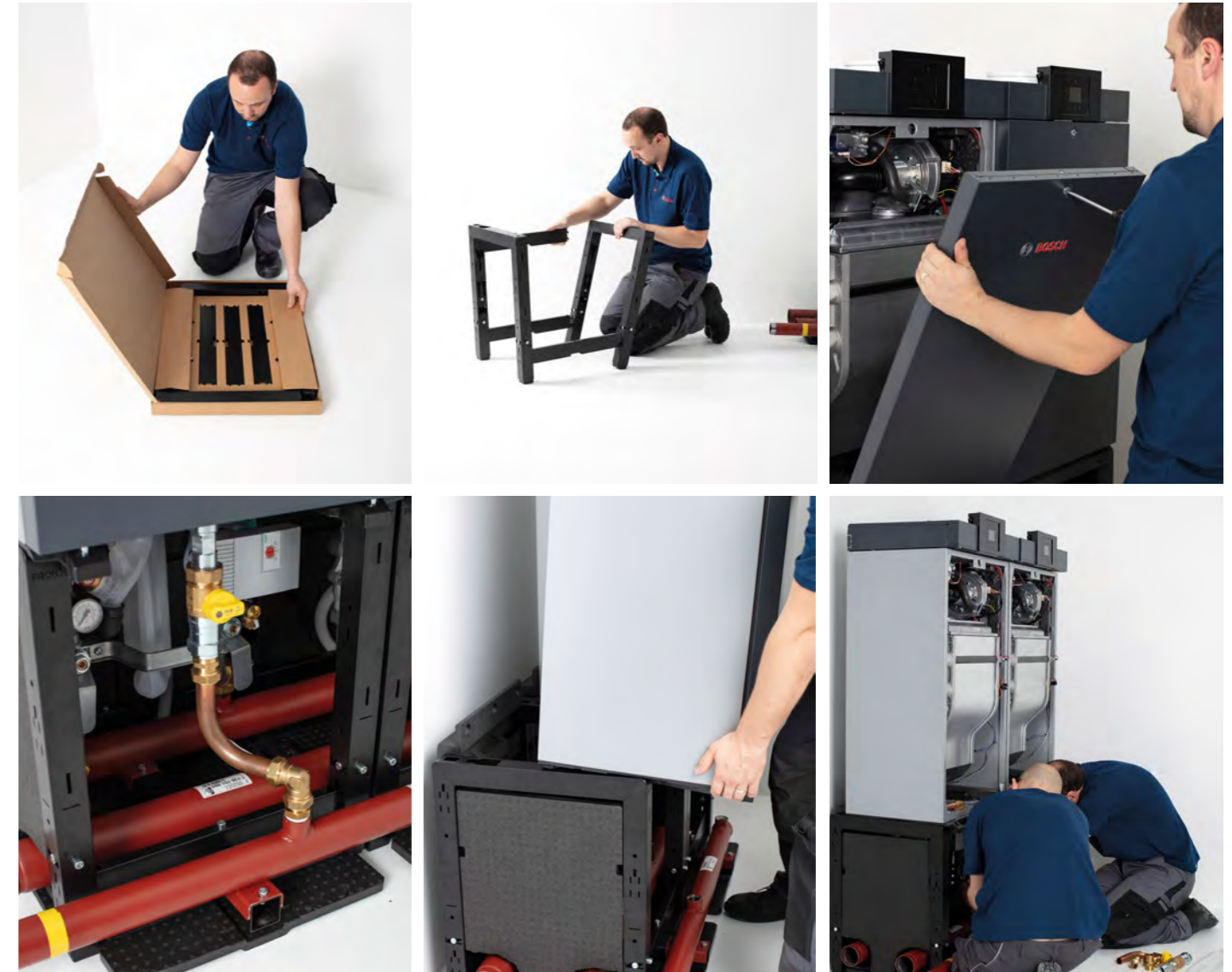

To help familiarise yourself with the installation process, there are step-by-step installation videos available as a guide on our website: bosch-industrial.co.uk/condens7000



*Time savings estimated and observed during customer installation studies.

Product breakdown

The inside story

GC7000WP 50-100kW



- 1 Basic controller BC30.2 for EMS plus
- 2 Ceramic burner with modulation ratio up to 1:5
- 3 Mounting option on the base frame for floor installation with “push and click-in” function for easy assembly
- 4 Simple connection of the control components from the top
- 5 All components accessible from the front for ease of maintenance and service
- 6 Patented ALU-Plus heat exchanger

GC7000WP 125-145kW

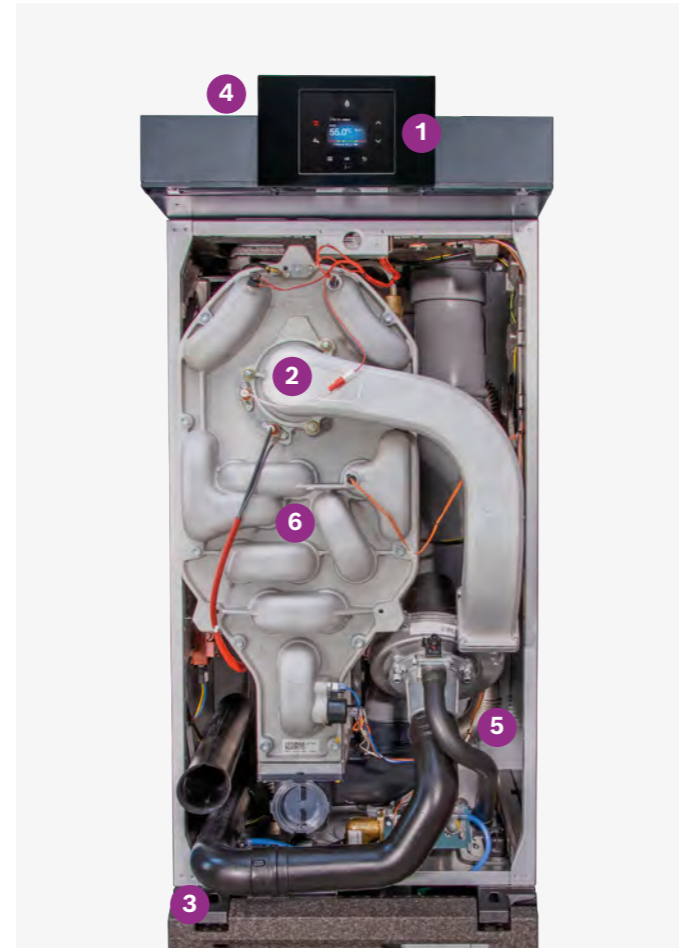

- 1 Basic controller BC30.2 for EMS plus
- 2 PFK grade burner with modulation ratio up to 1:6
- 3 Mounting option on the base frame for floor installation with “push and click-in” function for easy assembly
- 4 Simple connection of the control components from the top
- 5 All components accessible from the front for ease of maintenance and service
- 6 Patented ALU-Plus heat exchanger

Hydraulics, gas, pump connections and handles

- ▶ Front gas connection for easy access
- ▶ Easy electric connection box at bottom for pump group connections
- ▶ Comfortable bottom handles for confident handling
- ▶ “Slide and guide” – self-guiding transport slides
- ▶ Hydraulic CH connection



Modulating pump groups

Pump connection group for 50 and 65kW



- 1 Pressure Relief Valve (PRV)
- 2 Manometer
- 3 Service valve supply
- 4 Gas cock
- 5 Y-piece connector
- 6 Service valve return
- 7 Drain valve
- 8 Expansion vessel connection
- 9 Pump

- ▶ Pump connection group for 50 and 65kW with WILO-Para STG 25/8
- ▶ Supplied with 3 bar PRV as standard

Pump connection group for 85-145kW



- 1 Pressure Relief Valve (PRV)
- 2 Manometer
- 3 Service valve supply
- 4 Gas cock
- 5 Y-piece connector
- 6 Service valve return
- 7 Drain valve
- 8 Expansion vessel connection
- 9 Pump

- ▶ Pump connection group for 85 and 100kW with Wilo-Para Maxo 8
- ▶ 85 and 100kW pump group supplied with 3 bar PRV as standard
- ▶ Pump connection group for 125 and 145kW with WILO-Stratos PARA C-12
- ▶ 125 and 145kW pump group supplied with 4 bar PRV as standard

Upgrade your PRV

Product code	Part number
Pressure relief valve 4 bar (50-145kW)	7-095-595
Pressure relief valve 6 bar (50-145kW)	7-736-700-914

Heat exchanger

Patented ALU-Plus heat exchanger

- ▶ The precision engineered heat exchanger is constructed from a cast aluminium silicate compound which is lightweight, robust and allows for a rapid transfer of heat.
- ▶ The heat exchanger uses the latest ALU-Plus technology that has been developed by us, to increase durability and optimise efficiency. Fins on the outside of the aluminium tubes increase the exterior surface area so that more hot flue gas comes into contact with the heat exchanger.
- ▶ A spiral channel on the inside of the tube increases the internal surface area, bringing more water in contact with the heating surface and ensuring an optimum heat transfer. The wide channels on the heat exchanger ensure that the flow resistance is minimised and this, combined with its fully insulated case, makes the Condens 7000 WP incredibly quiet in operation.

Plasm-polymerised heat exchanger

- ▶ The surfaces of the heat exchanger's tubes are treated using a patented plasma-polymerisation process which leaves the surfaces so smooth that the heat exchanger effectively stays clean as no deposits can adhere to them.
- ▶ Its extremely high efficiency is maintained and there is no need for mechanical cleaning; the heat exchanger can be simply flushed through during servicing.

Heat Cell 50-100kW

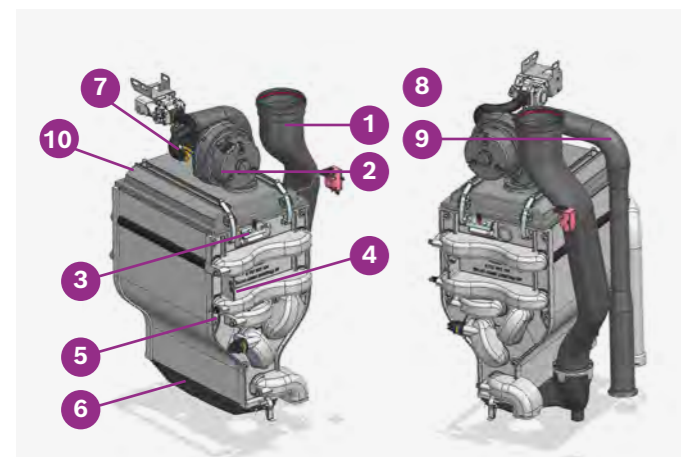

- | | |
|---|--------------------------------|
| 1 Flue exhaust
Ø110mm | 6 Condensate tray |
| 2 Fan | 7 Secured gas way
EPDM tube |
| 3 Spark igniter,
ionization sensor | 8 Gas valve |
| 4 Side wall
mounting in
boiler casing | 9 Air suction pipe |
| 5 Supply
temperature
limiter switch | 10 Auto air vent |

Heat Cell 125-145KW (C8)

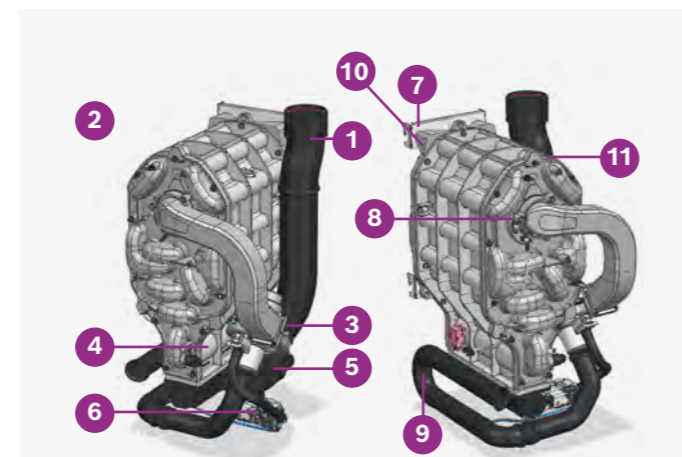

- | | |
|---|---|
| 1 Flue exhaust
Ø110mm | 6 Condensate tray
with inspection
opening |
| 2 Fan | 7 Secured gas way
EPDM tube |
| 3 Spark igniter,
ionization sensor | 8 Gas valve |
| 4 Back wall
mounting in
boiler casing | 9 Air suction pipe |
| 5 Supply
temperature
limiter switch | 10 Auto air vent |
| | 11 Integrated flue
non-return valve |

Wiring and connections

The control design ensures you have top access to do your input and output connections. The unit has integrated cable routing to keep the wiring neat. One EMS plus module (such as the MU100 for 0-10v connection to a BMS system) can be integrated into the boiler.

Low voltage connections

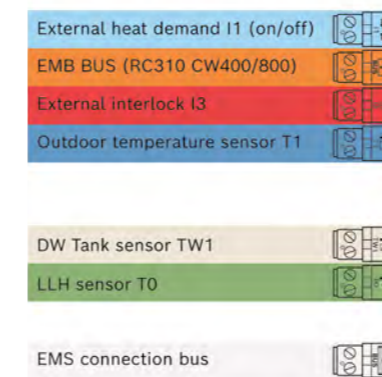

High voltage connections

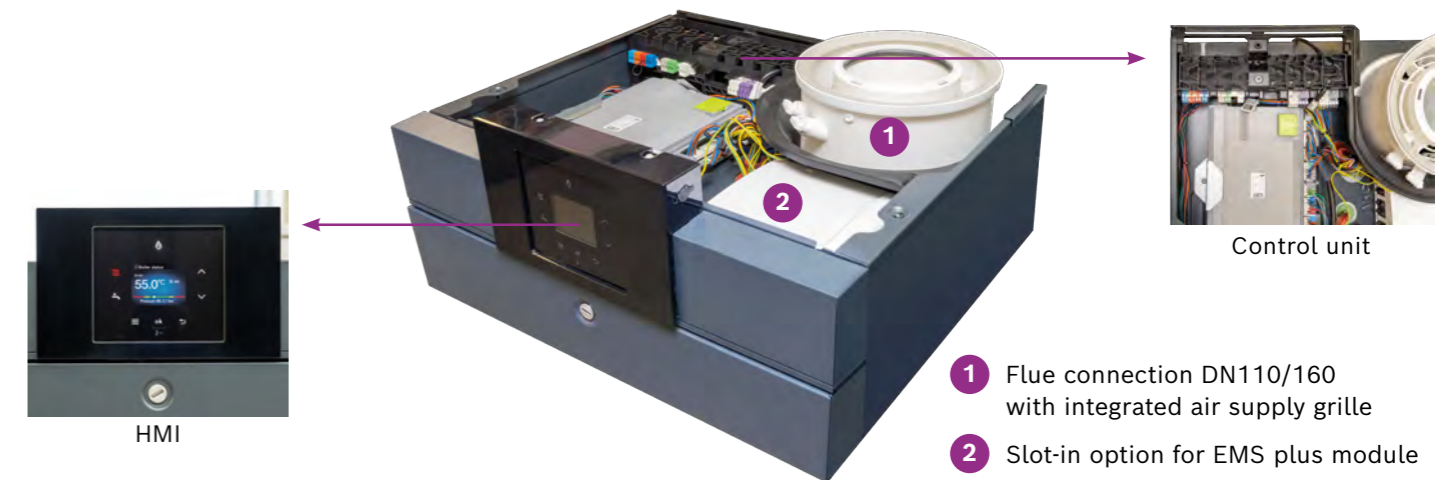
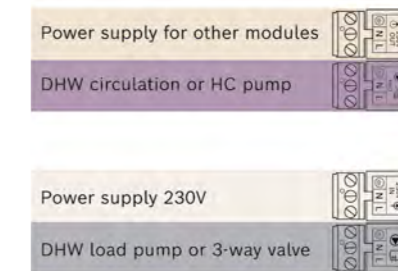

Control display

Full colour display (38.5mm x 50.7mm) with touch buttons

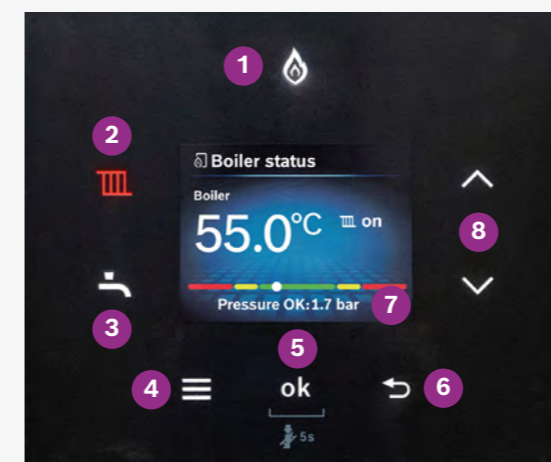

- | | |
|-----------------------------------|---------------------------------------|
| 1 Burner indicator | 6 Return button |
| 2 Heating button | 7 Heating water pressure
indicator |
| 3 Hot water button | 8 Buttons △ and ▽ |
| 4 Menu button | |
| 5 Button OK
Chimney sweep mode | |

Specification considerations

These pages provide an overview of the main installation and system requirements for the Condens 7000 WP. The full installation instructions supplied with the boiler must be adhered to before any work on the heating system takes place.

Space requirements

The Condens 7000 WP can be wall-mounted or as part of a cascade frame. When considering the final mounting position, it is important the required service and maintenance clearances are taken into account.

Minimum space required for the boiler:

Provide an unobstructed space of at least 100cm in front of the boiler to allow maintenance to be carried out.

Distance from walls at sides:

Maintain a clearance of at least 5mm on either side of the boiler.

See page 9 of installation manual for full clearances.

CAD and BIM

Files are available for download in DWG and RFA format from the website here:

<https://www.bosch-industrial.com/bim>

50-100kW boiler

GC7000WP boiler on frame

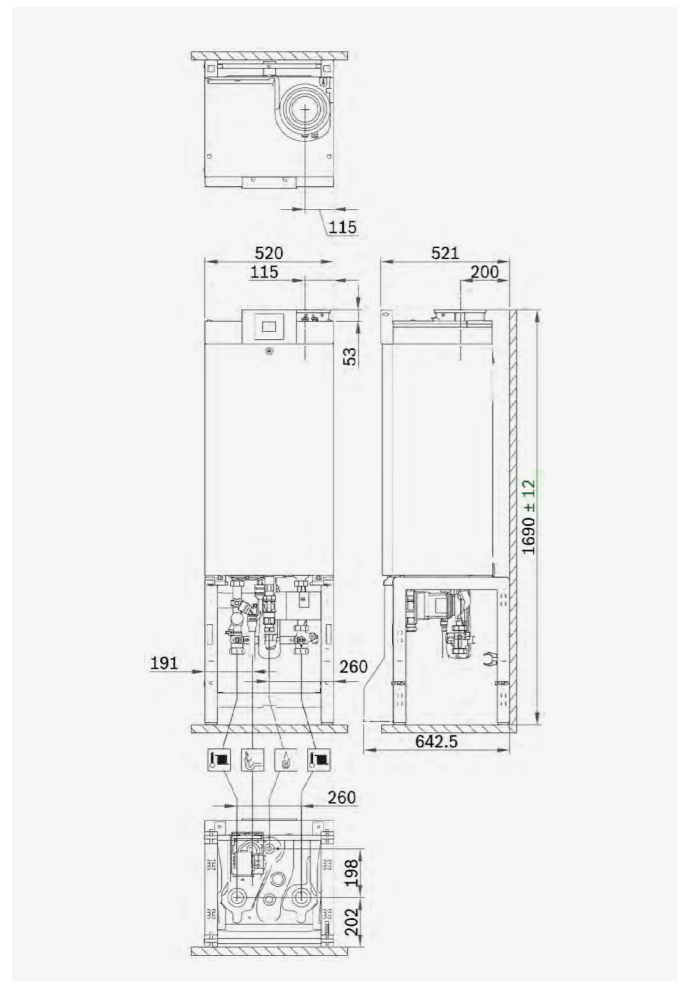

GC7000WP boiler on wall

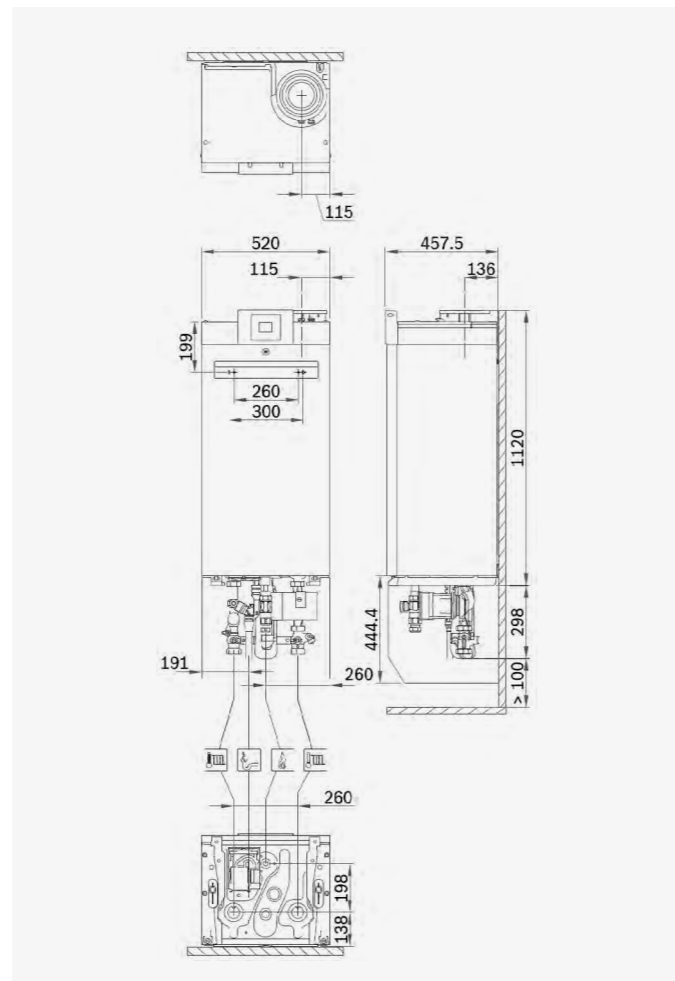

125 and 145kW boiler

GC7000WP boiler on frame

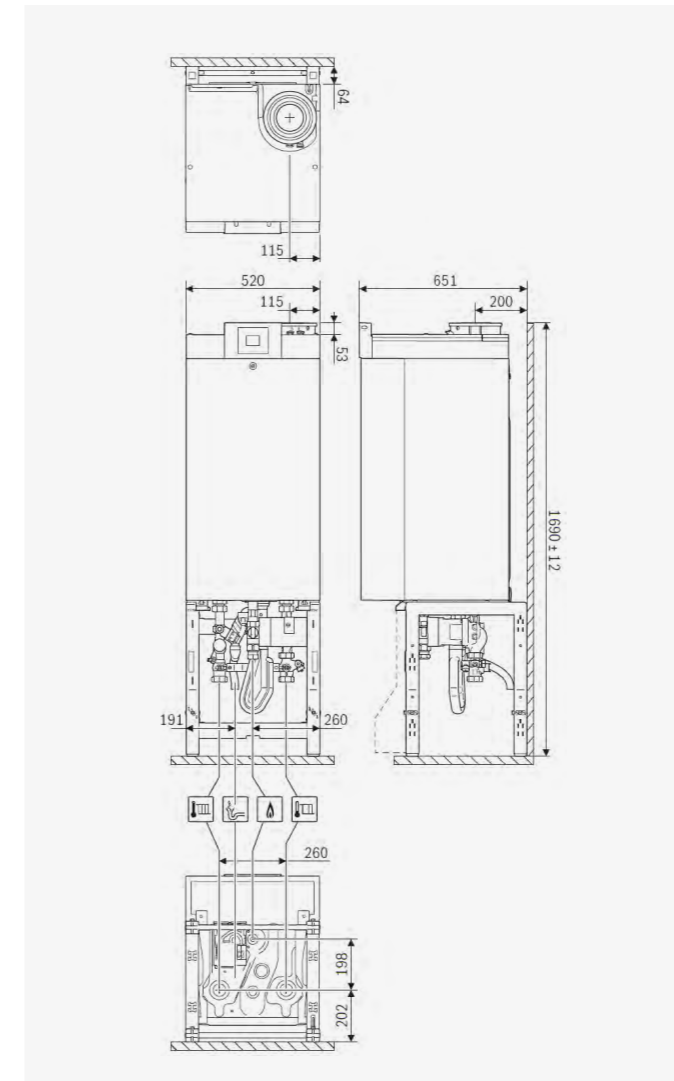

GC7000WP boiler on wall

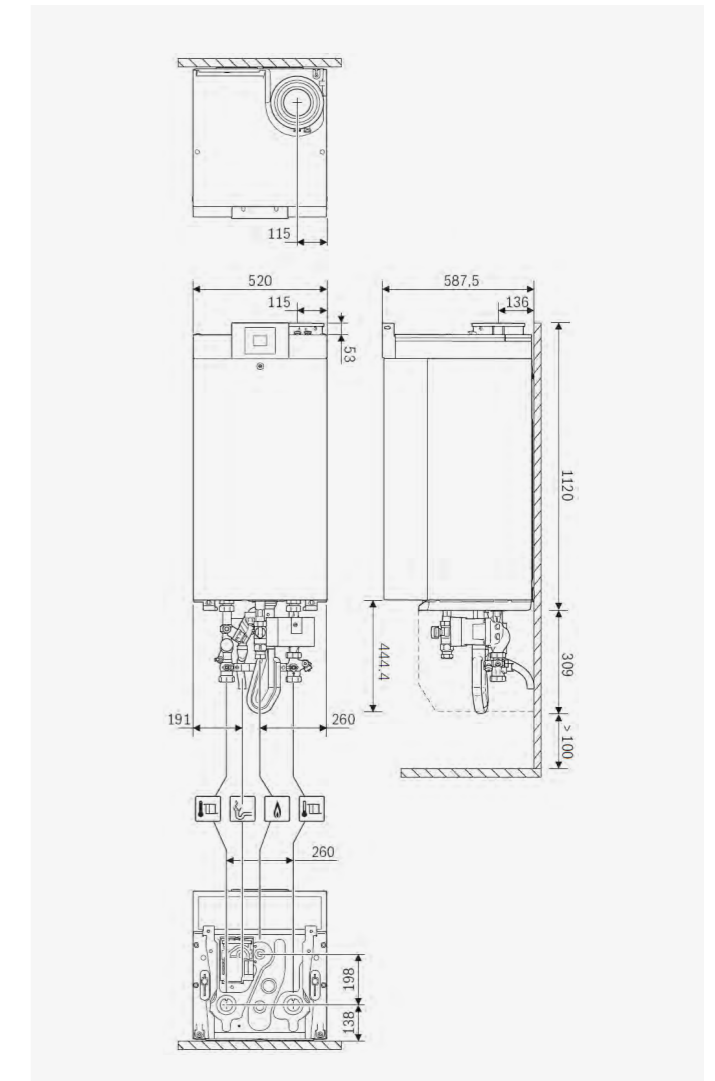

In-line (TL) arrangement

GC7000WP TL front

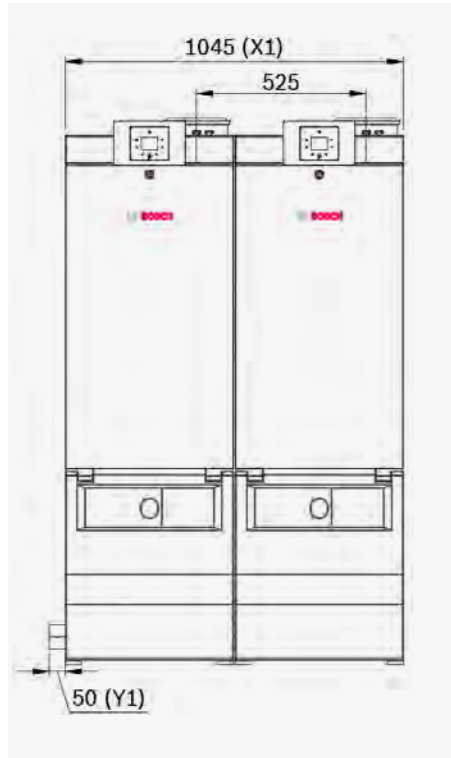

GC7000WP TL 50-100kW

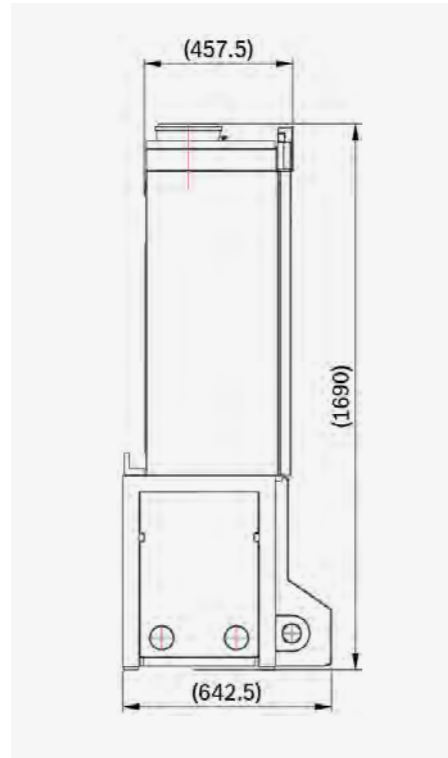

GC7000WP 125 and 145kW

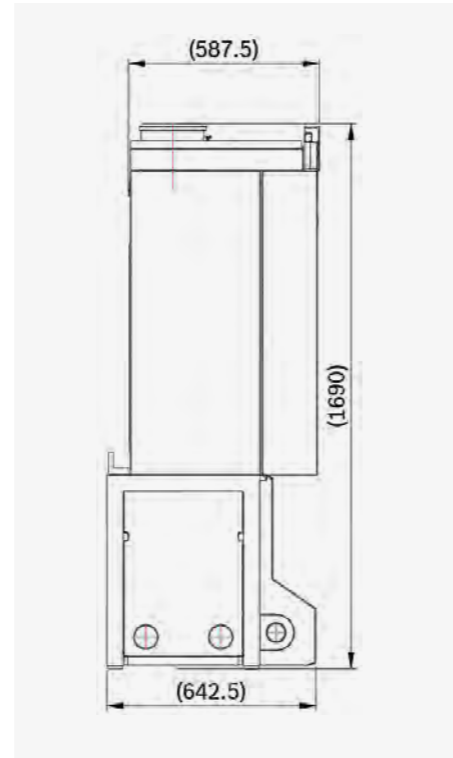

Orientation	X1 + Y1 (mm)
TL1	520 + 50 = 570
TL2	1045 + 50 = 1095
TL3	1570 + 50 = 1620
TL4	2095 + 50 = 2145
TL5	2620 + 50 = 2670
TL6	3145 + 50 = 3195

Orientation	X1 mm (boiler)	Y1 mm (spigot)	L1 mm (LLH length)	Overall (mm)
TL1	520	50	492.8	1062.8
TL2	1045	50	492.8	1587.8
TL3	1570	50	796.5	2416.5
TL4	2095	50	796.5	2941.5
TL5	2620	50	796.5	3466.5
TL6	3145	50	796.5	3991.5

Back-to-back arrangement

GC7000WP TL front



GC7000WP TL 50-100kW

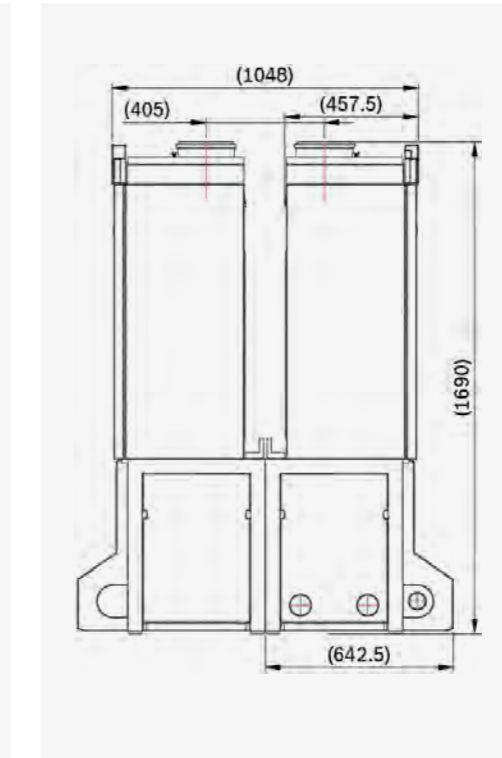

GC7000WP 125 and 145kW

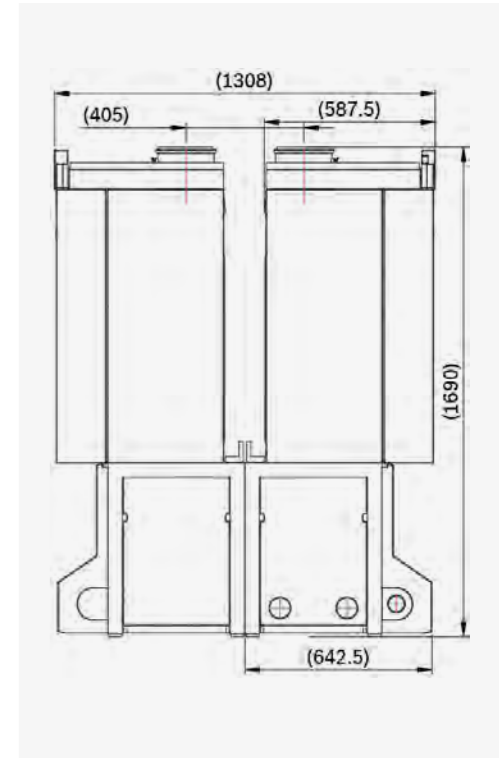

Orientation	X1 + Y1 (mm)
TR2	520 + 50 = 570
TR3 & TR4	1045 + 50 = 1095
TR5 & TR6	1570 + 50 = 1620

Orientation	X1 mm (boiler)	Y1 mm (spigot)	L1 mm (LLH length)	Overall (mm)
TR2	520	50	492.8	1062.8
TR3 & TR4	1045	50	492.8	1587.8
TR5 & TR6	1570	50	796.5	2416.5

Water system connections

When to use a low loss header or plate heat exchanger

The Condens 7000 WP must be installed on a sealed system in accordance with BS EN 12828.

For open vented systems or systems that are particularly contaminated, a plate heat exchanger should be used to separate the boiler circuit from the main system. Matched plate heat exchanger packs for the boiler or cascade output capacity are available to make selection simpler (see control section for guidance on positioning of flow temperature sensor).

For clean sealed systems where multiple heating circuits or DHW circuits controlled by separate pumps are used, it is necessary to incorporate a low loss header. Cascade kits with the appropriately sized low loss header included are available as a pack (please refer to page 35 for part numbers). The low loss header acts to hydraulically separate the boiler pump groups from the heating circuit pumps and avoids hydraulic issues that could affect the correct control of the heating system. Always use a low loss header (or plate heat exchanger) where there is more than one pump in the system.

Residual pump head

For single boiler applications, the matched boiler pump group has been selected to cope with typical radiator heating systems that are constructed in accordance with UK building regulations requirement of separating zones above 150m². Under these circumstances the residual head available from the boiler pump should be sufficient to cope with most typical radiator heating circuit resistance.

For older heating circuits that do not comply with modern building regulations, or for applications with high system resistance, a low loss header should be used.

85 and 100kW residual pump head

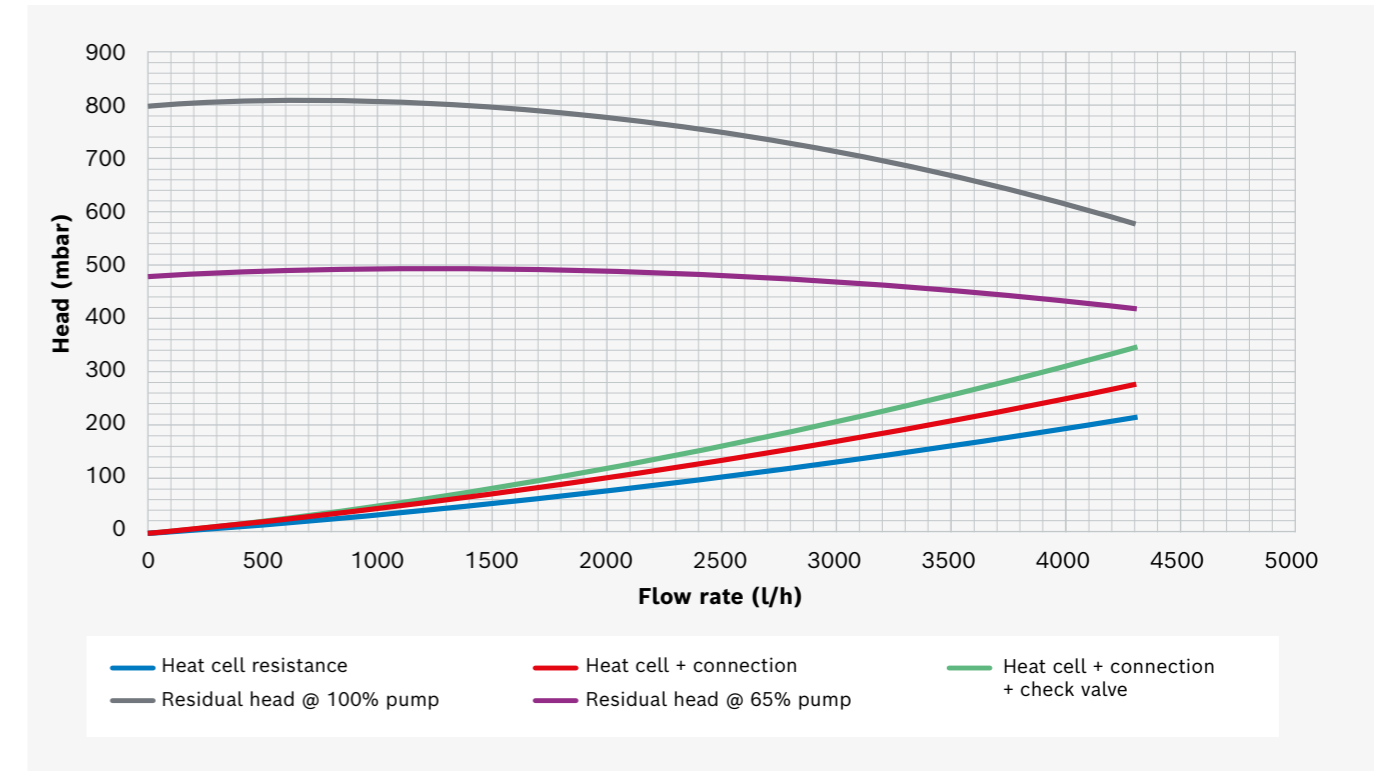

50 and 65kW residual pump head

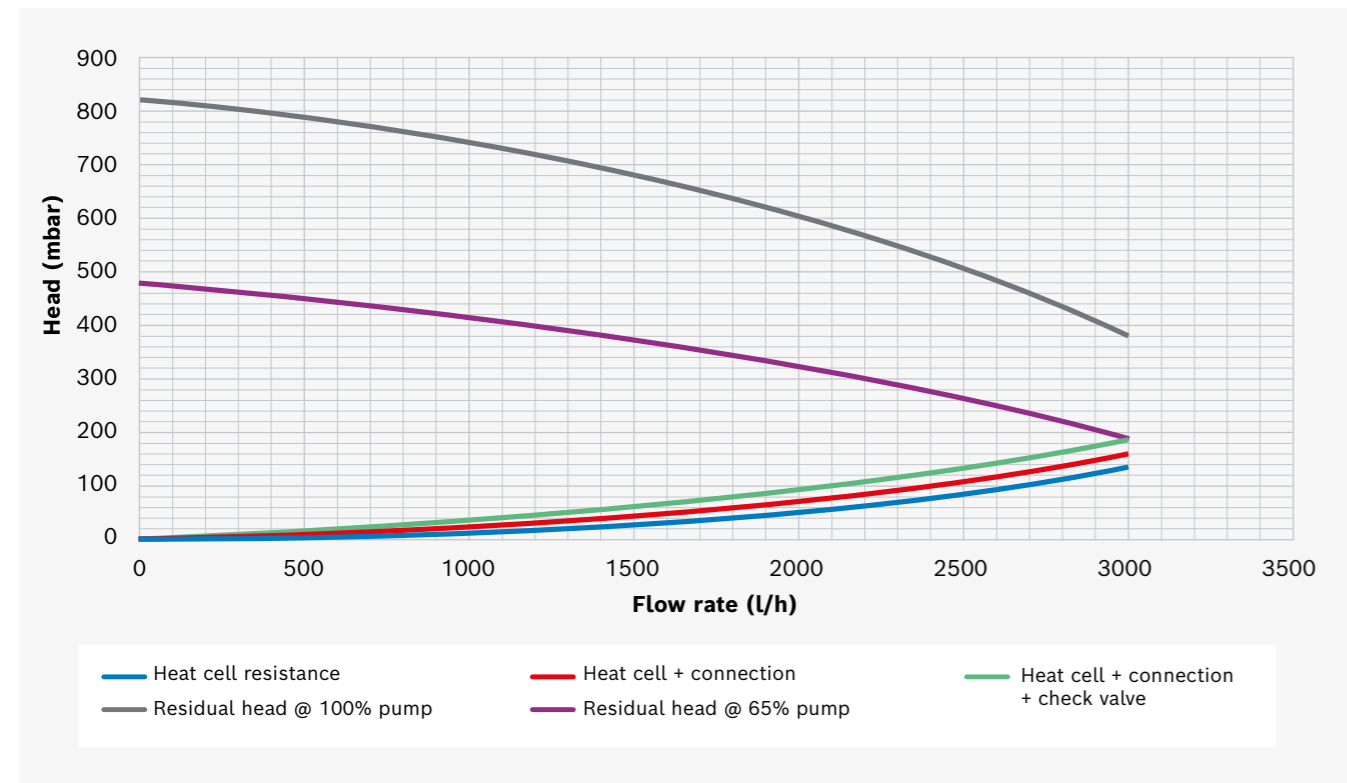

125 and 145kW residual pump head

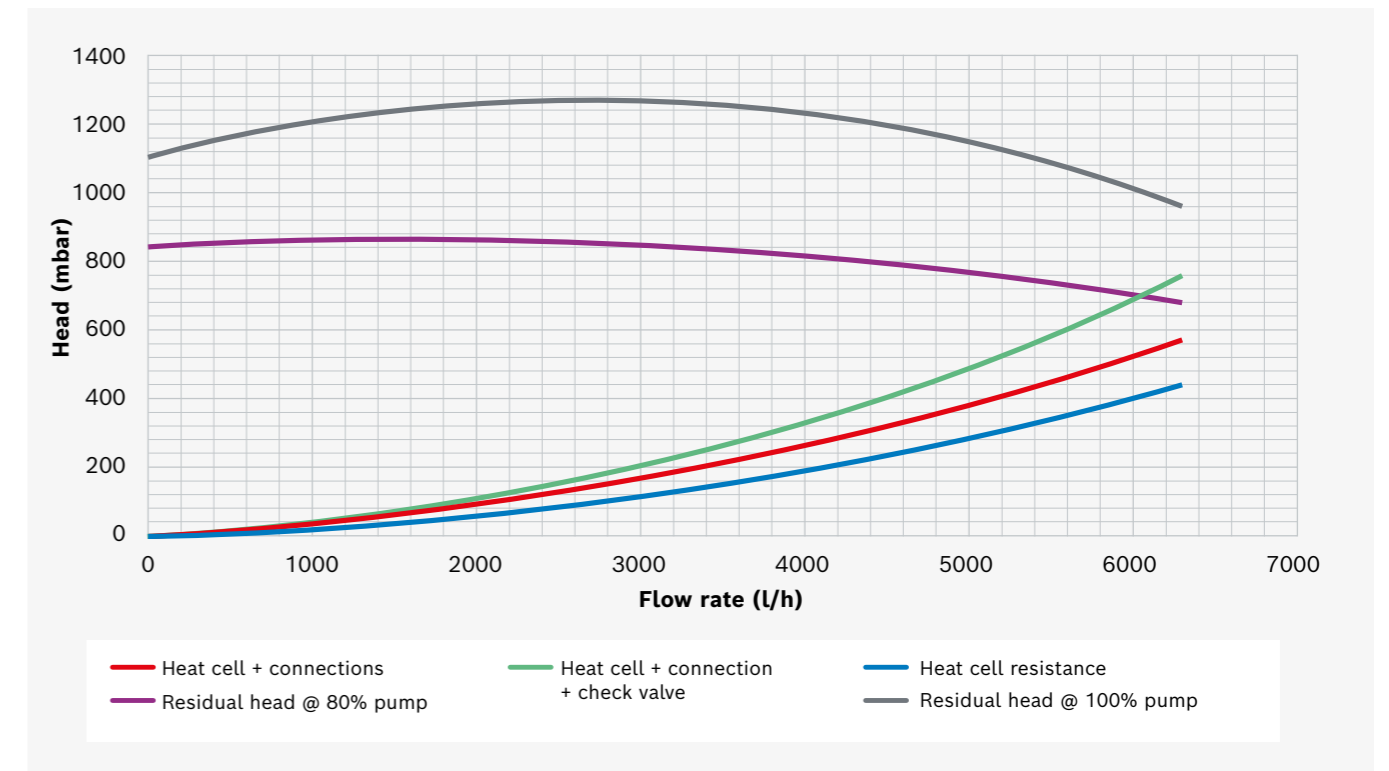

Maximum temperature difference

Heating systems designed for use with condensing boilers such as our Condens 7000 WP are at their most efficient when the return temperature is below 55 degrees. To help achieve these conditions, industry guidance recommends rebalancing older heating systems designed to operate at 82/71 to 80/60 (ΔT 20K). When this is combined with weather compensated heating circuit operation, the return temperature will regularly be below 55 degrees on all but the coldest days.

However, the maximum temperature difference should be kept below ΔT 25K. Above this temperature difference the boiler will modulate its output to ensure it continues to operate safely.

Water quality

We strongly recommend thoroughly flushing the system before filling it and using only untreated tap water when filling the system. The use of dirty water will lead to build-ups of sediment and corrosion, which can result in the boiler malfunctioning and cause damage to the heat exchanger.

Do not treat the water with pH-adjusting substances (chemical additives) or anti-freeze (other than Fernox Alpha 11) or water softeners. Sentinel X100 or Fernox MB1 can be used to achieve the desired water quality. The concentration of Sentinel or Fernox should be in accordance with the manufacturer's instructions for the volume of the water in the system.

Water treatment following the requirements of VDI 2035 may be used.

The pH of the heating system must be between 7 and 8.5. If this is not the case, please contact our technical support team before proceeding, tel. 0330 123 9229.

Artificially softened water must not be used with the Condens 7000 WP.

Quality of the pipe work

When using plastic pipe work in the heating system, e.g. for underfloor heating, it has to be oxygen-tight according to the relevant UK standards. If plastic pipes do not comply with these standards, the system parts must be separated using a plate heat exchanger.

Filling the system (water regulations)

In the UK, methods for filling heating systems are covered by the water regulations. The regulations ensure that backflow of contaminated heating system water does not enter the water supply. It is important to understand these requirements and how they relate to the type of building (house or non-house) as well as the boiler output size.

For most non-domestic applications there will be a need to comply with fluid categories 4 and 5, meaning that a simple filler loop cannot meet the requirements.

Gas supply requirements

Low gas pressure will lead to reduced boiler outputs, so it is important to ensure the gas installation can provide the necessary supply capacity and pressures.

For natural gas, the inlet supply pressure should be within 17mbar to 25mbar (see installation manual for guidance when measuring gas pressures as the appliance gas multi-function valve).

Before installation commences, the capacity of the gas meter supply should be checked to be sufficient for all of the gas appliances connected to the installation.

For the 50 and 65kW boilers in domestic properties where installers carrying out the installation hold domestic ACS qualifications only, the installation of the gas supply must comply with IGE/UP/1b. This means that the gas meter must be no greater than 16m³/h, the pipework no more than 35mm and the installation volume does not exceed 0.035m³.

LPG conversion

LPG conversion kits are available for all of the outputs. For LPG installations, the gas supply pressure should be between 25mbar and 45mbar with adequate protection for over and under pressure.

Ensure the siting of the appliance is not below ground level and that low level ventilation meets the requirements of the appropriate standard.

Available conversion sets

Product	Part number
Conversion set 3P (G31) (45-50KW)	7-736-702-378
Conversion set 3P (G31) (60-70KW)	7-736-702-379
Conversion set 3P (G31) (80-85KW)	7-736-702-380
Conversion set 3P (G31) (90-100KW)	7-736-702-381
Conversion set 3P (G31) (125KW)	7-736-701-860
Conversion set 3P (G31) (145-150KW)	7-736-701-861

Which control is right for my install?

There are a range of control options for differing applications when using the Condens 7000 WP either as a single boiler or as a cascade. Please use our handy guide below to find the one best suited for your install.

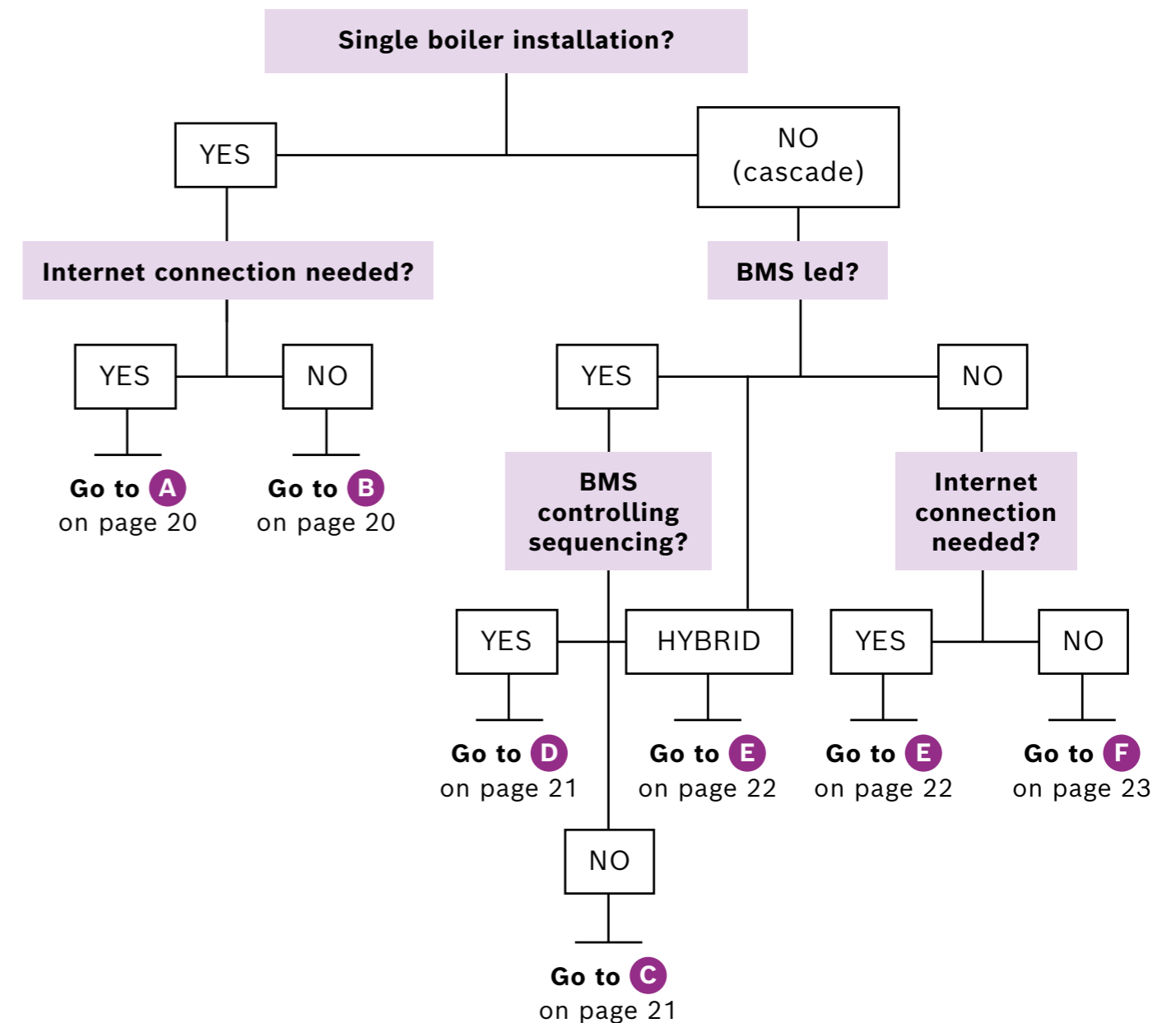

A Single boiler installation – internet-connected controls



Bosch EasyControl controller
7-736-701-341 (white)
7-736-701-392 (black)

The Bosch EasyControl is a smart internet-connected room thermostat, offering a simple, stylish and intuitive solution to optimise home comfort.

When combined with our Smart TRVs, homeowners can easily control the heating in each individual room, to achieve the perfect heating environment (feature only available for 50-100kW models).

The device can be connected to the boiler using a 2-core cable.



3 way valve
7-736-701-881

3 way valve allows for priority DHW generation, must be used in conjunction with a Sense II or EasyControl.

Plugs into the boiler's harness plug – 1 1/4" connections.

You must ensure that the cylinder coil is rated to at least 50% of the boiler's output. If demand is lower than 50%, refer to control option B, below.

B Single boiler installation – standard controls

If an internet connection is not required for your install, the Sense II controller in combination with expansion modules MM100 can be used. Where the system also includes solar thermal, either the MS100 or MS200 can be used. Where there are multiple heating circuits, a Sense I can be used to give individual zone control.



Sense II
7-738-111-064

The Sense II control platform uses the EMS 2 Energy Management System which allows advanced functions such as weather compensated control and optimum start.

Weather compensation is particularly useful for larger buildings where it can be difficult to locate a good reference room to suit the area being heated. A north facing outside sensor is used to determine the correct flow temperature needed to achieve the desired room temperature, based on a heating curve. Local TRV's on radiators, for example, can then fine tune the final room temperature to suit the occupants.

Using weather compensation allows lower flow temperatures for large parts of the heating season, which in turn leads to lower return temperatures to help make the condensing boiler more efficient.



MM100
7-738-110-140
Used for additional heating circuit (maximum of 4) or additional DHW circuit (maximum of 1).



MS100
7-738-110-144
Module for integration of solar thermal panels.

The benefits of weather compensation

The Sense II controller can change the required temperature for different heating circuits according to the outside temperature and is measured using a small external sensor.

With mixed heating circuits this means that each individual circuit has its own characteristics and the boiler will supply only the heat needed for certain parts of the system. This is particularly effective in Spring and Autumn so temperatures for the heating circuits can be reduced significantly – saving fuel and allowing the highest efficiency from the condensing process.

Flow Temp °C	Outside Temp °C
45	10
62	0
75	-10

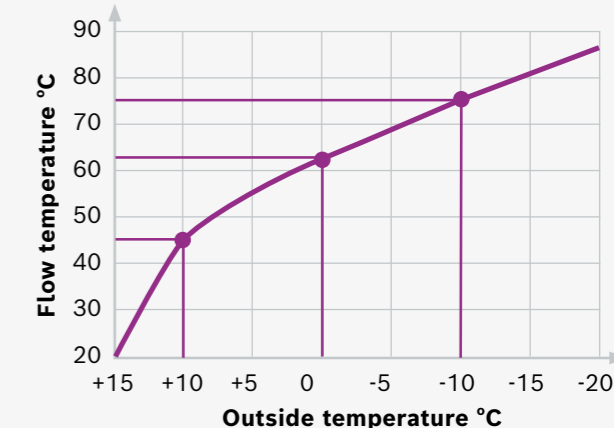

The graph above shows how the heating curve can be modified at any time using the Sense II controller, providing maximum comfort for the user.

C Cascade installation – BMS Led (Bosch controlling sequencing)



MC400 cascade sequencer
7-738-111-001

The MC400 simplifies the optimum running of a cascade system when interfacing with an existing BMS.

By rotating the lead boiler it eliminates excessive wear in any one unit and also interprets the 0-10V input signal from the BMS to modulate the heat output of the cascade. This is all achieved without the need for programming or complex set up and is a true “plug and play” control.

An individual MC400 can control up to 4 boilers and up to 16 boilers can be achieved when five MC400 units are linked together, up to 2.2MW.

Wet sensor (part number 7-735-600-657) must be used in conjunction with the MC400 cascade sequencer.

D Cascade installation – BMS Led (BMS controlling sequencing)



MU100 BMS interface module
7-738-110-145

The MU100 is used for each individual boiler and modules when interfacing with an existing BMS.

It can create a 230V fault signal, and has a 0-10V contact for signals from the BMS to control the boiler flow temperature.

E Cascade installation – internet-connected controls



Bosch CC8313 intelligent commercial control

7-736-602-245

The CC8313 is an intelligent commercial control offering internet-connected remote access and weather compensation as standard.

The control unit has the ability to work alongside or independent of a BMS system. With the addition of plug-in function modules, the CC8313 can be expanded to cascade boilers, add multiple heating circuits and provide control of two separate DHW circuits.

The CC8313 can control a DHW circuit as standard, additional function modules will be required for mixed or unmixed heating circuits. The CC8313 has the space available for up to four additional function modules.

Wet sensor (part number 7-735-600-656) must be used in conjunction with this control (please refer to page 21 for more details).



FM-MW heating and DHW control module

8-718-598-831

This controls one mixed or one unmixed heating circuit and one DHW circuit (with cylinder load and circulation pump).

All wiring has colour coded plugs for quick installation into the main control unit (BFU as accessory).



FM-MM heating circuit control module

8-718-598-828

This controls up to two mixed or unmixed circuits. Comes supplied with one FV/FZ temperature sensor.

All wiring has colour coded plugs for a quick installation into the main control unit (BFU up to 2x as accessory). An additional FV/FZ sensor is required if using two mixed circuits.



FM-CM cascade control module

7-736-602-098

The FM-CM can control the modulation and sequencing strategy from 2 to 4 boilers. A 0-10V input, for use with the BMS control.

BFU room thermostat

5-720-720

The BFU is a remote control which allows the temperature to be adjusted from the end user's living or working space. This includes a room temperature sensor.

F Cascade installation – standard controls

Gives cascade control for use with existing heating and hot water time and temperature controllers.



MC400 cascade controller

7-738-111-001

For heating systems where an existing control system will be reused and is not capable of sequencing and rotating a cascade, the MC400 is the perfect solution. The MC400 can control up to four boilers as a single control unit, but can be connected to other MC400 controllers to control up to 16 boilers (requires five MC400s). The controller will sequence the boilers to match the demand and rotate the lead boiler to ensure even use across the cascade.

MC400 has several different configuration options that allow 0-10VDC or 230V enable signals from an existing external controller. A 230V alarm signal is also available to indicate a fault situation.

A flow sensor (part number 7-735-600-657) is required for the low loss header or plate heat exchanger.

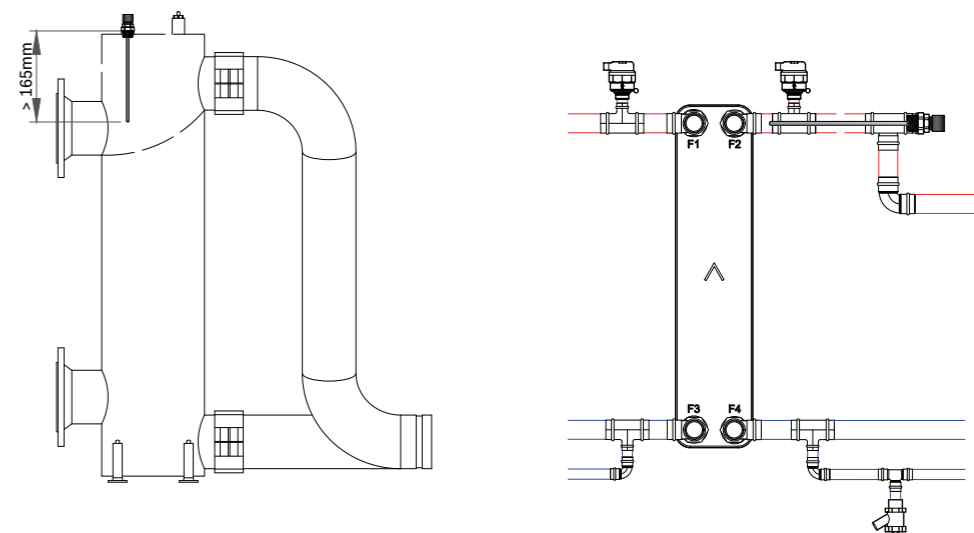

Available controls, modules and sensors

Product	Part number	Product	Part number
Programmer MU100	7-738-110-145	Module FM-MW	8-718-598-831
MM100 mixer and LLH module	7-738-110-140	Module FM-MM	8-718-598-828
MC400 cascade sequencer	7-738-111-001	Module FM-AM	7-736-602-079
MS200 intelligent solar module	7-738-110-146	FV/FZ temperature sensor set	5-991-376
Greenstar Sense II	7-738-111-064	VPN router ERT50	7-736-603-505
Greenstar Sense I	7-738-110-054	Module FM-RM (VPN router mounting rail)	8-732-900-362
CC8313 intelligent commercial control	7-736-602-245	Flow sensor (8313 controller)	7-735-600-656
Control CC8310 (module extension)	7-736-605-958	Flow sensor (MC400 controller)	7-735-600-657
Module FM-CM	7-736-602-098		

Flues and ventilation

The topic of fluing and ventilation for commercial boilers is a detailed one that crosses several industry standards and regulations.

To help guide installers and system designers, we have produced a dedicated flue and ventilation guide for commercial installations, which is available to download from our website.

Additionally, a separate flue manual is available for the Condens 7000 WP boiler range, also downloadable from our website.

Concentric flue options

Standard flue options are available for individual boilers using room sealed (RS) concentric flue systems. The Condens 7000 WP has an extensive range of concentric flue components available for horizontal, vertical and plume management terminations.

C13 and C33 concentric flue lengths and reductions



The following equivalent flue lengths and reduction for bends are applicable to the Condens 7000 WP boiler range.

7000 WP boiler series horizontal room sealed fluing options

Horizontal room sealed flue

Maximum equivalent flue lengths	110/160 mm	90° Bend	45° Bend
7000 WP 50kW	11m	1.5m	0.5m
7000 WP 65kW	16m	1.5m	0.5m
7000 WP 85 kW	11m	1.5m	0.5m
7000 WP 100 kW	12m	1.5m	0.5m
7000 WP 125 kW	3m	1.5m	0.5m
7000 WP 145 kW	3m	1.5m	0.5m

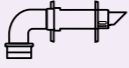
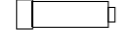
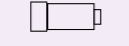
110/160mm horizontal room sealed flue accessories

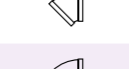
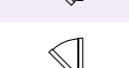
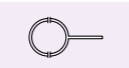
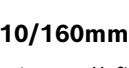
Components	Part number	Description
	7-738-113-669	110/160mm dia. horizontal flue kit
	7-738-113-100	110/160mm dia. 1m flue extension
	7-738-113-099	110/160mm dia. 0.5m flue extension
	7-738-113-101	110/160mm dia. 2m flue extension
	7-738-113-105	110/160mm dia. 87° bend
	7-738-113-104	110/160mm dia. 45° bend
	7-738-113-103	110/160mm dia. 30° bend
	7-738-113-102	110/160mm dia. 15° bend
	7-738-113-677	Flue wall clamps 160mm dia. (pack qty. 3)

110/160mm horizontal flue kit

- ▶ 1 x wall finishing plate (white)
- ▶ 1 x external wall finishing plate (stainless)
- ▶ 1 x external flue terminal (stainless)
- ▶ 1 x 87° bend
- ▶ 1 x horizontal flue (500mm length)

Part No. 7-738-113-669



Standard horizontal flue assembly

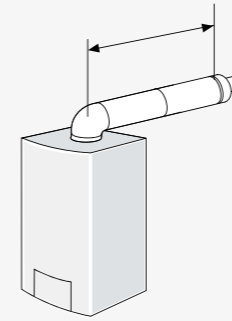

Components	
Part No. 110/160mm	7-738-113-669
Maximum lengths (mm) & no. of components required	
7000 WP 50kW	1115mm 1
7000 WP 65kW	1115mm 1
7000 WP 85kW	1115mm 1
7000 WP 100kW	1115mm 1
7000 WP 125kW	1115mm 1
7000 WP 145kW	1115mm 1

Extension flue horizontal

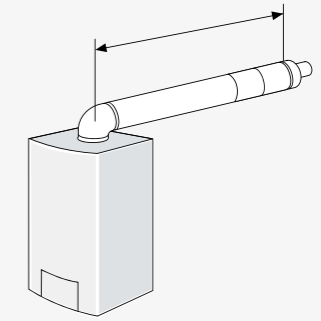

Components		
Part No. 110/160mm	7-738-113-669	7-738-113-100
Maximum lengths (mm) & no. of components required		
7000 WP 50kW	11,000mm	1 up to 10
7000 WP 65kW	16,000mm	1 up to 15
7000 WP 85kW	11,000mm	1 up to 10
7000 WP 100kW	12,000mm	1 up to 11
7000 WP 125kW	3,000mm	1 up to 2
7000 WP 145kW	3,000mm	1 up to 2

Extension flue horizontal using a second 90° bend

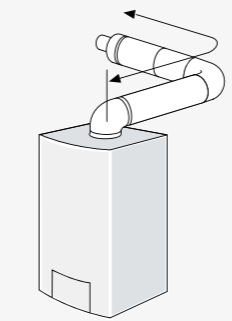

Components			
Part No. 110/160mm	7-738-113-669	7-738-113-100	7-738-113-105
Maximum lengths (mm) & no. of components required			
7000 WP 50kW	9,500mm	1 up to 8	1
7000 WP 65kW	14,500mm	1 up to 13	1
7000 WP 85kW	9,500mm	1 up to 8	1
7000 WP 100kW	10,500mm	1 up to 9	1
7000 WP 125kW	1,500mm	1	N/A 1
7000 WP 145kW	1,500mm	1	N/A 1

Note:

The maximum flue length must be reduced by the following amounts for each bend used.

7000 WP 50, 65, 85, 100, 125, 145kW 110/160mm flue	
45° bend	0.5m
87° bend	1.5m

Extension flue horizontal and upwards

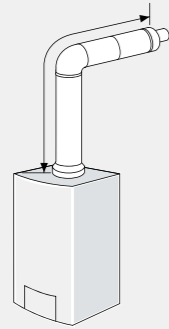

Components	7-738-113-669	7-738-113-100	7-738-113-105
Part No. 110/160mm			

Maximum lengths (mm) & no. of components required

7000 WP 50kW	7000 WP 65kW	7000 WP 85kW	7000 WP 100kW	7000 WP 125kW	7000 WP 145kW
11,000mm	16,000mm	11,000mm	12,000mm	3,000mm	3,000mm
1	1	1	1	1	1
up to 10	up to 15	up to 10	up to 11	up to 2	up to 2
0*	0*	0*	0*	0*	0*

*Horizontal flue kit includes a 90° bend.

Extension flue upwards and horizontal using a second 90° bend

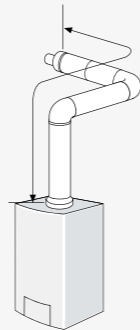

Components	7-738-113-669	7-738-113-100	7-738-113-105
Part No. 110/160mm			

Maximum lengths (mm) & no. of components required

7000 WP 50kW	7000 WP 65kW	7000 WP 85kW	7000 WP 100kW	7000 WP 125kW	7000 WP 145kW
9,500mm	14,500mm	9,500mm	10,500mm	1,500mm	1,500mm
1	1	1	1	1	1
up to 8	up to 13	up to 8	up to 9	N/A	N/A
1*	1*	1*	1*	1*	1*

*Horizontal flue kit includes a 90° bend, therefore only 1 additional bend needs to be ordered.

Notes:

- ▶ The short 0.5m flue extension may be used as an alternative to the standard extension.
- ▶ The maximum flue length must be reduced by the following amounts for each bend used.

7000 WP 50, 65, 85, 100, 125, 145kW 110/160mm flue	
45° bend	0.5m
87° bend	1.5m

7000 WP boiler series vertical room sealed fluing options

Vertical room sealed flue

Maximum equivalent flue lengths	110/160 mm	90° Bend	45° Bend
7000 WP 50kW	21m	1.5m	0.5m
7000 WP 65kW	22m	1.5m	0.5m
7000 WP 85kW	16m	1.5m	0.5m
7000 WP 100kW	16m	1.5m	0.5m
7000 WP 125kW	5m	1.5m	0.5m
7000 WP 145kW	5m	1.5m	0.5m

110/160mm vertical room sealed flue accessories

Components	Part number	Description
	7-738-113-668	110/160mm dia. vertical flue kit
	7-738-113-100	110/160mm dia. 1m flue extension
	7-738-113-099	110/160mm dia. 0.5m flue extension
	7-738-113-101	110/160mm dia. 2m flue extension
	7-738-113-105	110/160mm dia. 87° bend
	7-738-113-104	110/160mm dia. 45° bend
	7-738-113-103	110/160mm dia. 30° bend
	7-738-113-102	110/160mm dia. 15° bend
	7-738-113-677	Flue wall clamps 160mm dia. (pack qty. 3)
	7-738-113-126	110/160mm dia. Flat roof flashing 0° 170mm
	7-738-113-127	110/160mm dia. Flat roof flashing 0° - 15° 170mm
	7-738-113-128	110/160mm dia. 5 - 25° pitched roof flashing
	7-738-113-129	110/160mm dia. 25 - 45° flashing

Notes:

- ▶ The short 0.5m flue extension may be used as an alternative to the standard extension.
- ▶ The maximum flue length must be reduced by the following amounts for each bend used.

7000 WP 50, 65, 85, 100, 125, 145kW 110/160mm flue	
45° bend	0.5m
87° bend	1.5m



110/160mm vertical flue kit

- ▶ 1 x flue terminal
- ▶ 1 x support bracket
- ▶ 1 x inner duct
- ▶ 1 x outer duct

Part No. 7-738-113-668

Standard vertical flue assembly

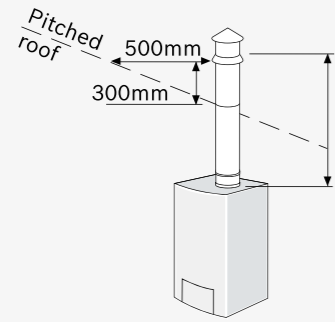

Components	
Part No. 110/160mm	7-738-113-668

Maximum lengths (mm) & no. of components required

7000 WP 50kW	
2,000mm	1
7000 WP 65kW	
2,000mm	1
7000 WP 85kW	
2,000mm	1
7000 WP 100kW	
2,000mm	1
7000 WP 125kW	
2,000mm	1
7000 WP 145kW	
2,000mm	1

Vertical balanced flue system maximum height

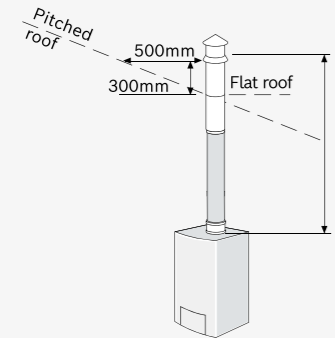

Components		
Part No. 110/160mm	7-738-113-668	7-738-113-100

Maximum lengths (mm) & no. of components required

7000 WP 50kW		
21,000mm	1	up to 19
7000 WP 65kW		
22,000mm	1	up to 20
7000 WP 85kW		
16,000mm	1	up to 14
7000 WP 100kW		
16,000mm	1	up to 14
7000 WP 125kW		
5,000mm	1	up to 3
7000 WP 145kW		
5,000mm	1	up to 3

Vertical balanced flue system with two 45° bends

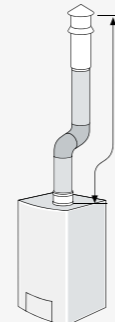

Components			
Part No. 110/160mm	7-738-113-668	7-738-113-100	7-738-113-104

Maximum lengths (mm) & no. of components required

7000 WP 50kW			
20,000mm	1	up to 18	2
7000 WP 65kW			
21,000mm	1	up to 19	2
7000 WP 85kW			
15,000mm	1	up to 13	2
7000 WP 100kW			
15,000mm	1	up to 13	2
7000 WP 125kW			
5,000mm	1	up to 2	2
7000 WP 145kW			
4,000mm	1	up to 2	2

Vertical balanced flue system with two 90° bends

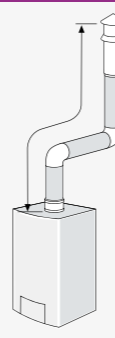

Components			
Part No. 110/160mm	7-738-113-668	7-738-113-100	7-738-113-105

Maximum lengths (mm) & no. of components required

7000 WP 50kW			
18,000mm	1	up to 16	2
7000 WP 65kW			
19,000mm	1	up to 17	2
7000 WP 85kW			
13,000mm	1	up to 11	2
7000 WP 100kW			
13,000m	1	up to 11	2
7000 WP 125kW			
2,000mm	1	N/A	2
7000 WP 145kW			
2,000mm	1	N/A	2

Please refer to the installation manual and flue guidance document for further information.

Plume management flue kit

For single boilers, sometimes finding a suitable compliant flue termination position can be difficult. Plume management kits allow termination positions to be raised up to a level where plume is less likely to cause a nuisance, allowing more options for a compliant flue termination position. The plume management kit replaces a standard horizontal terminal and allows a concentric flue system to be used internally, where the boiler is positioned some distance from the outside wall.

All external components are made from stainless steel to ensure a durable long life flue system. Stainless steel bends and additional sections allow further options depending on the site conditions.

For further information about permissible flue lengths, please refer to the flue installation manual for the 7000 WP.



Available accessories

Product	Part number	Product	Part number
Plume management kit, Ø110/160	7-738-113-670	Supply air intake Ø110/160 stainless	7-738-113-147
Pipe concentric Ø110/160 0,5m stainless	7-738-113-140	Wall bracket Ø160, 40-65mm stainless	7-738-113-149
Pipe concentric Ø110/160 1,0m stainless	7-738-113-141	Extension wall bracket Ø160, 65-165mm	7-738-113-150
Pipe concentric Ø110/160 2,0m stainless	7-738-113-142	Extension wall bracket Ø160, 178-284mm	7-738-113-151
Elbow concentric Ø110/160 15° stainless	7-738-113-143	Extension wall bracket Ø160, 294-394mm	7-738-113-152
Elbow concentric Ø110/160 30° stainless	7-738-113-144	Extension console Ø160, 54-187mm	7-738-113-153
Elbow concentric Ø110/160 45° stainless	7-738-113-145	Extension console Ø160, 180-271mm	7-738-113-154
Elbow concentric Ø110/160 87° stainless	7-738-113-146	Extension console Ø160, 271-362mm	7-738-113-155



B23 open flues

For situations when a suitable room sealed flue run cannot be found, open flue systems using existing chimneys or purpose made flue systems can be used. The Condens 7000 WP has a range of flue components for use with B23 open flue systems.



Flue via an existing chimney

For individual boilers, DN110 flue system components are available to line existing chimneys and connect the boiler to the lining. Rigid sections, available in 500mm, 1,000mm and 2,000mm, can be used with flue spacers, terminal, and base sections to build a complete flue system. For chimneys that are not straight, DN110 flexible liners are available in 15m and 25m lengths. Installation tools are also available.



C93 room sealed flues

Where a room sealed flue arrangement is desired, but it is not possible to use a standard concentric flue to achieve this, the C93 flue option using an existing chimney is possible. The chimney must be inspected and found to be sound, clean and of minimum size before this option can be considered. C93 flue systems use the chimney as a supply duct for combustion air via a special terminal and base section. The inner exhaust duct uses standard flue components similar to those described in the B23 flue for both rigid and flexible options.



Cascade combined flue systems

One of the advantages of a Condens 7000 WP cascade is the ability to combine individual boiler flues into a common flue header using off-the-shelf recommended flue components. There are two types of cascade flue systems, which should be considered at the design stage.

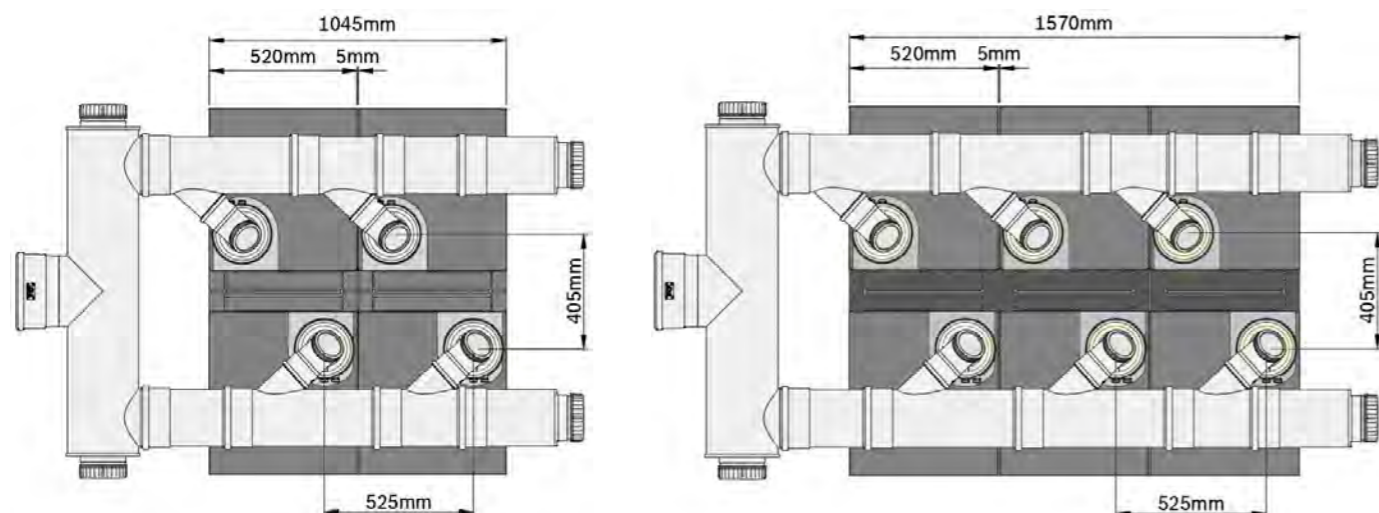

Natural draught cascade flues

Cascade flue systems that rely on natural draught are durable due to their simplicity. They require a minimum vertical height and diameter based on the cascade output and can use existing chimneys, operating as an open flue system.

Where no chimney is available, flues can be run externally using standard twin wall stainless steel components. Internal flue runs must consider any fire protected areas they may pass through and local Building Regulations.

Standard cascade flue headers are available to suit all common cascade arrangements.

Over pressure cascade flues

Where the use of a natural draught flue system is difficult to achieve, due to chimney size and height restrictions, an over pressure flue system can be used. This provides greater flexibility to achieve compliant flue options in demanding situations.

Over pressure flue systems use an individual non-return valve at each boiler flue exit to ensure there are no possibilities of flue spillage when a boiler is not operating. The Condens 7000 WP incorporates a flue safety sensor which monitors the non-return valve is fully shut. If the non-return valve does not shut completely, the flue sensor activates the boiler fan and creates an alarm to maintain safety.

The over pressure non-return valve comes as standard with our Condens 7000 WP 125kW and 145kW range.

Non Return Valve

7-736-701-917

Non return valve for overpressure flue cascade kit 50-100kW (not required for 125 & 145kW)



Boiler room safety

CO sensors for cascade flue systems

Bosch has taken the decision to require the mandatory use of CO detection for boiler systems using cascade flue systems, such as the 7000 WP, where there is more than one appliance connected. This is to reflect state of the art in the industry and will help to raise safety standards.

The base cascade flue kits now contain a CO detector for use in the installation. For third party cascade flue system, a CO detector that is interlocked with the boilers will be required. A suitable CO detector is available as an accessory.

Part Numbers:

CO Detector - 7-736-606-211

CO-Detector & Cut-off module set - 7-736-606-214

Typical use cases

The Condens 7000 WP has been developed to allow specifiers and heating engineers greater flexibility to design heating systems, providing reliable and efficient performance for any project.

The following hydraulic schematics show just some of the many options that are available for individual and cascade installations.

Single boiler application

Single boiler applications are most commonly found in large domestic or light commercial applications such as restaurants, churches and more.

Single boiler (heating + hot water)

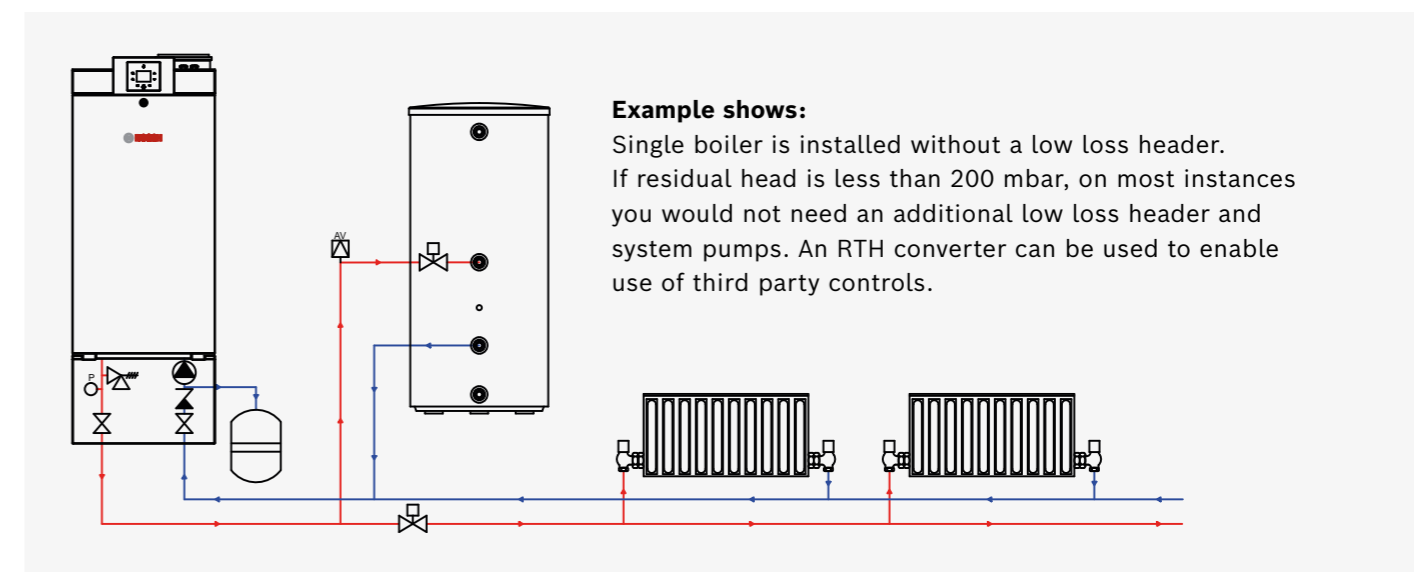

Single Boiler with plate heat exchanger (heating + hot water)

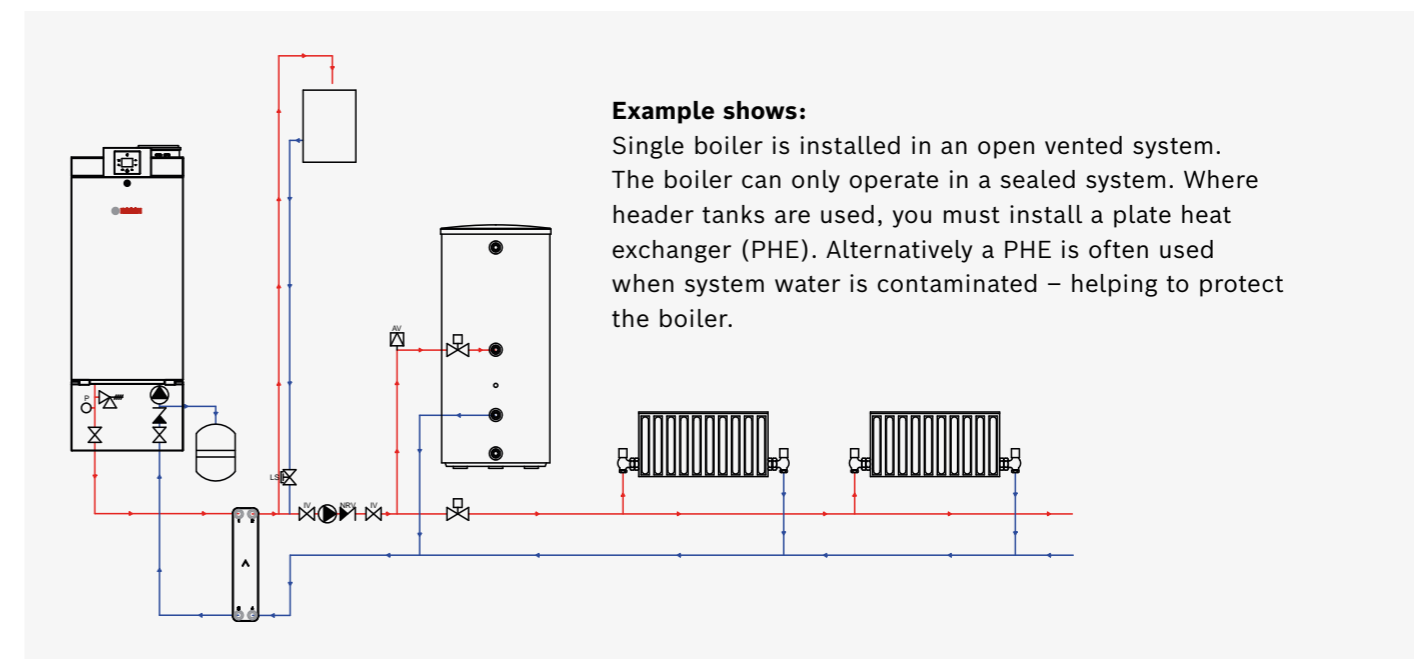

Single Boiler (heating only)

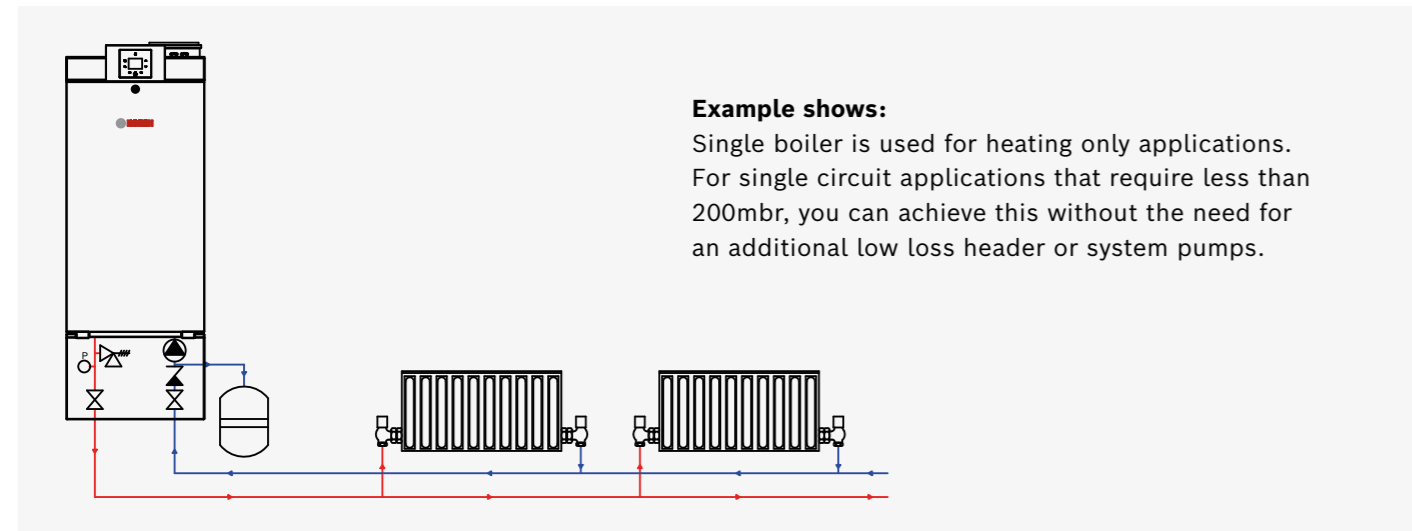

Single boiler with diverter valve (heating + hot water)

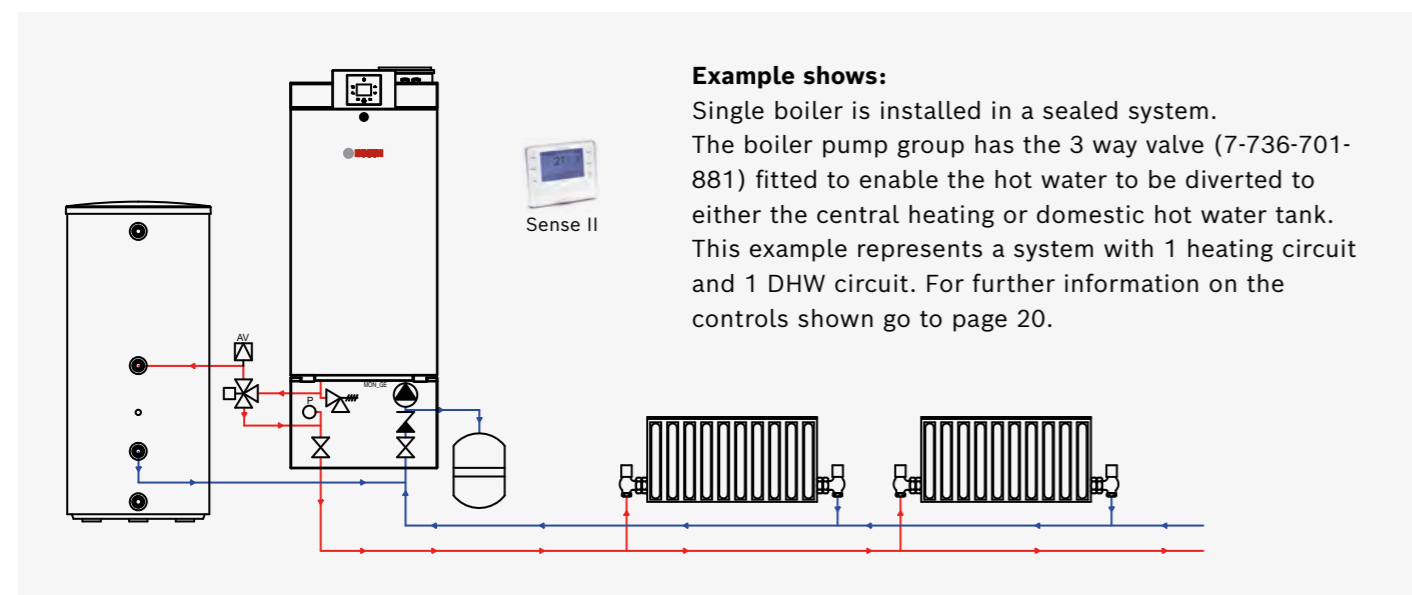

Single boiler with LLH (heating + hot water)

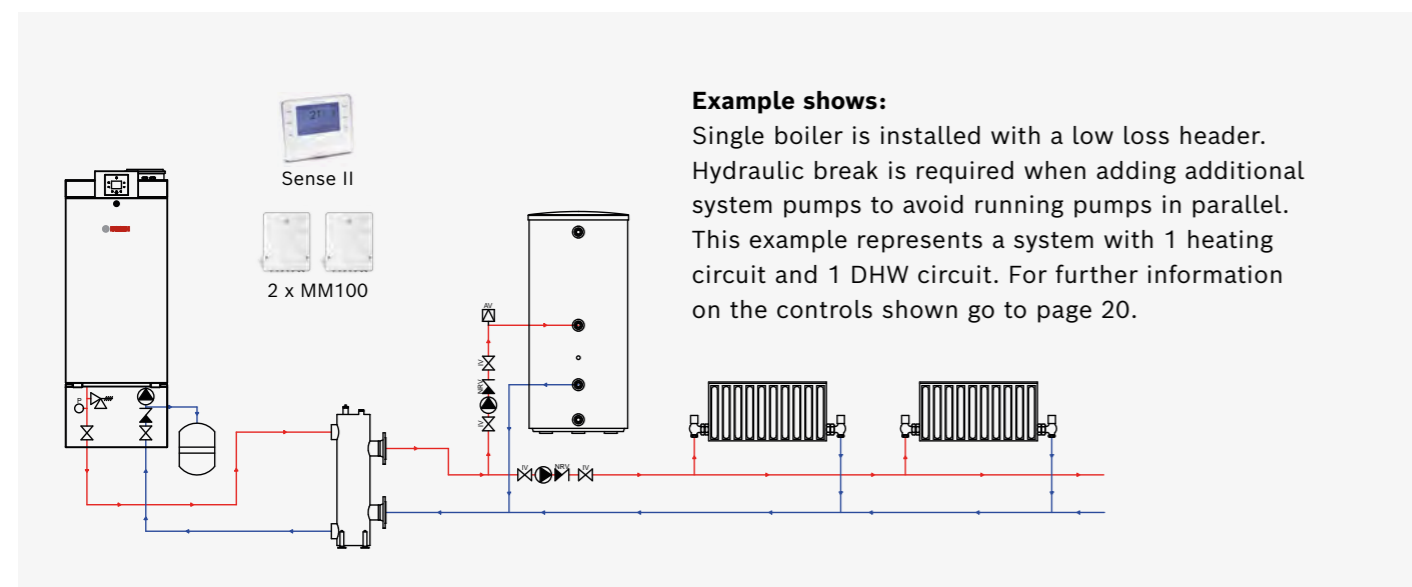

Cascade application

It is important that a cascade controller is always used when cascading our 7000 WP boilers. The following examples show how this is achieved using either the MC400 or 8313 controllers.

Cascade with LLH (heating + hot water) using MC400 cascade sequencer (BMS run signal)

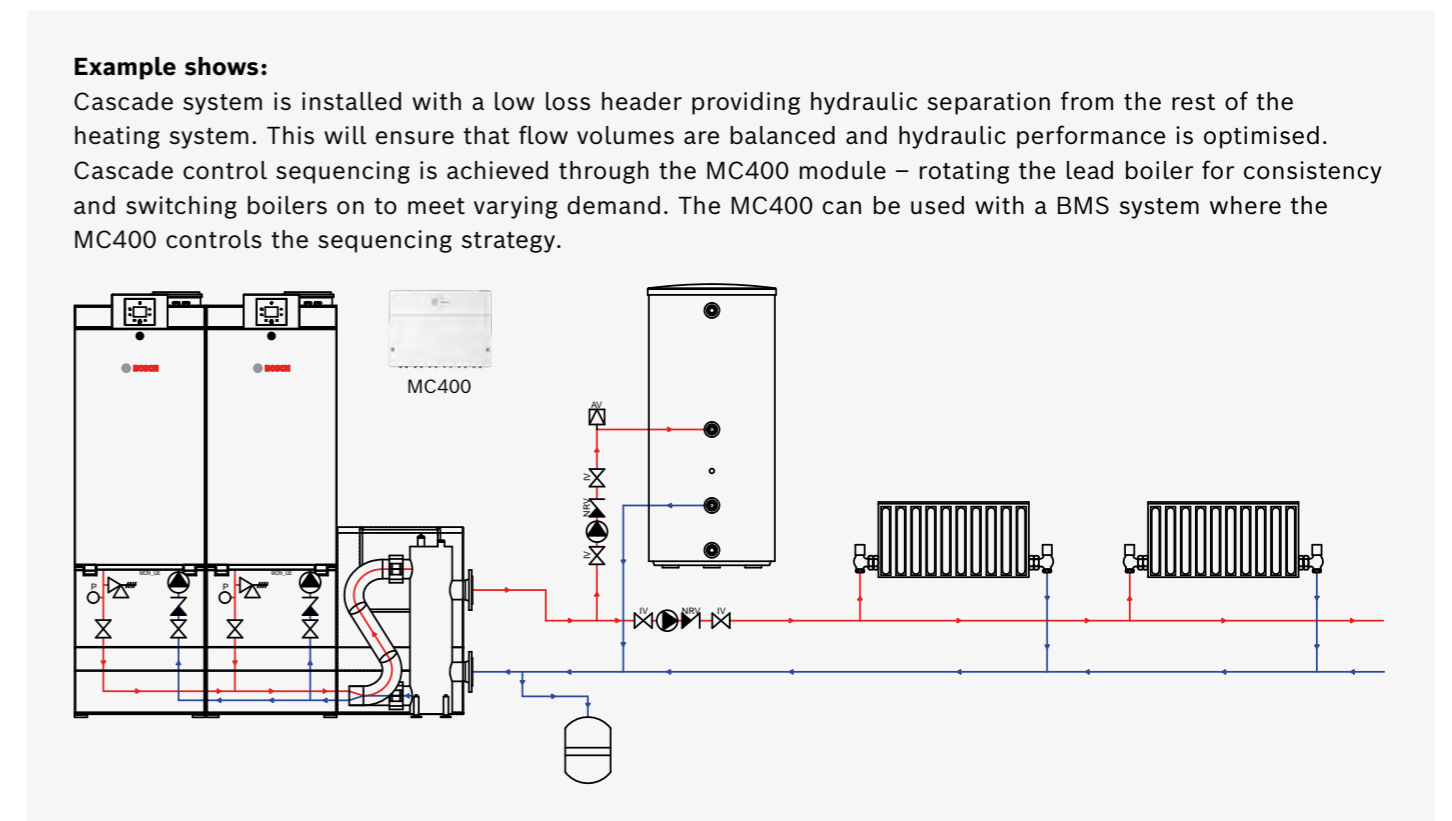

Cascade with LLH (heating + hot water) using CC8313 controller

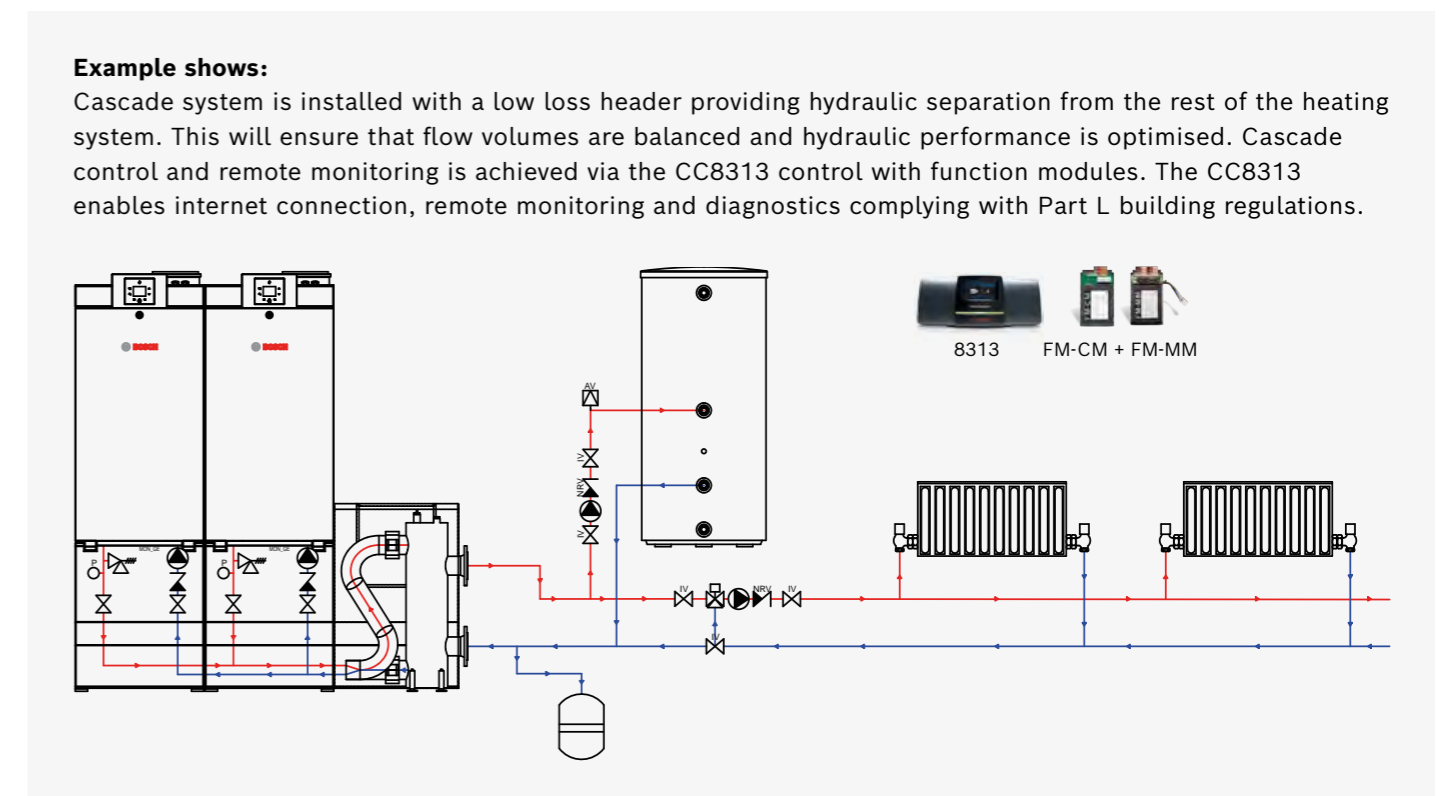

Getting started



REGISTER A PRODUCT

To register a boiler or cascade system and activate the 5 year guarantee, click the link below, or scan the QR code:

bosch-industrial.co.uk/guarantee



BOOK COMMISSIONING

In order to book commissioning for a boiler or cascade system, simply visit the below link, or scan the QR code, and complete the pre-commissioning checklist:

bosch-industrial.co.uk/commissioning



*Terms & conditions apply. Please visit bosch-industrial.co.uk/guarantee-terms-and-conditions for details



Boiler configurations

Single boiler

The Condens 7000 WP can be configured in various ways to meet the heating demands of your installation. Please use the numbered steps below to choose the correct boiler configuration for your project. Please contact us if you require assistance.



A
A++ → G

Dimensions 50-100kW	
Width	520mm
Height	1,429mm*
Depth	458mm
Dimensions 125-145kW	
Width	520mm
Height	1,429mm*
Depth	588mm

**ErP only relevant to 50kW and 65kW models.
*Height with pump group

1 Boiler

Description	Part number
Bosch Condens GC7000WP 50kW	7 736 702 194
Bosch Condens GC7000WP 65kW	7 736 702 195
Bosch Condens GC7000WP 85kW	7 736 702 196
Bosch Condens GC7000WP 100kW	7 736 702 197
Bosch Condens GC7000WP 125kW	7 736 702 198
Bosch Condens GC7000WP 145kW	7 736 702 199

2 Pump group (1 required per boiler)

Description	Part number
Pump group 70kW (3 bar PRV) (for use with 50kW and 65kW boilers)	7 736 701 864
Pump group 100kW (3 bar PRV) (for use with 85kW and 100kW boilers)	7 736 701 865
Pump group 150kW (4 bar PRV) (for use with 125kW and 145kW boilers)	7 736 702 214

3 Wall hung or frame set option

Wall hung	Part number
Pump group insulation	7 736 701 876
Pump group connection set	5 584 552

Floor standing frame*	Part number
TL1 frame set with insulation*	7 736 701 912
Pump group connection set	5 584 552

*TL1 floor standing frame available with flow and return headers if required, please contact your local CTM.

4 Hydraulic separation options (if required)

Low loss header**

Optional accessories	Part number
Sinus LLH 180kW***	8 920 097 2

Required accessories	Part number
Temperature sensor pocket (R1/2")	5 446 142

**Bosch 300kW LLH available if required, please contact your local CTM.
***Output requirements over 100kW must be designed to 20K ΔT.

Plate heat exchanger

Optional accessories	Part number	PHE connection type
50KW Plate heat exchanger	7 733 600 013	1 1/4" Male BSPP flat face
65KW Plate heat exchanger	7 733 600 014	1 1/4" Male BSPP flat face
80-100KW Plate heat exchanger	7 733 600 016	1 1/4" Male BSPP flat face
101-140KW Plate heat exchanger	7 733 600 017	2" Male BSPP flat face
141-180KW Plate heat exchanger	7 733 600 018	2" Male BSPP flat face

5 Controls

Bosch controls	Part number
Greenstar Sense II (interface controller)	7 738 111 064
MM100 (one required per zone)	7 738 110 140

BMS integration	Part number
MU100 Programmer	7 738 110 145

3rd party controls	Part number
RTH Converter (included as standard with 50 and 65kW variants)	7 807 9

Boiler configurations

Cascade boiler sets

Our Condens 7000 WP can be cascaded on a six boiler cascade frame set to achieve up to 860kW.

An ideal choice for applications where space is restricted but there is a demand for a modern high output, high efficiency heating solution. Control strategies can provide cascade and sequencing for up to 16 boilers at a time for up to 2.2MW of power.

1 Boiler

Description	Part number
Bosch Condens GC7000WP 50kW	7 736 702 194
Bosch Condens GC7000WP 65kW	7 736 702 195
Bosch Condens GC7000WP 85kW	7 736 702 196
Bosch Condens GC7000WP 100kW	7 736 702 197
Bosch Condens GC7000WP 125kW	7 736 702 198
Bosch Condens GC7000WP 145kW	7 736 702 199

2 Pump group (1 required per boiler)

Description	Part number
Pump group 70kW (3 bar PRV) (for use with 50kW and 65kW boilers)	7 736 701 864
Pump group 100kW (3 bar PRV) (for use with 85kW and 100kW boilers)	7 736 701 865
Pump group 150kW (4 bar PRV) (for use with 125kW and 145kW boilers)	7 736 702 214

3 Cascade frame sets

Cascade setup	Description	Part number
TL2	2 Boiler in-line cascade set with insulation	7 736 701 883
TL3	3 Boiler in-line cascade set with insulation	7 736 701 884
TL4	4 Boiler in-line cascade set with insulation	7 736 701 885
TL5	5 Boiler in-line cascade set with insulation	7 736 701 886
TL6	6 Boiler in-line cascade set with insulation	7 736 701 887

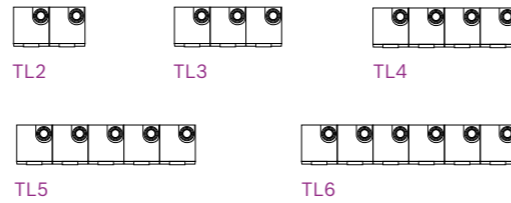

Cascade setup	Description	Part number
TR2	2 Boiler back-to-back cascade set with insulation	7 736 701 888
TR3	3 Boiler back-to-back cascade set with insulation	7 736 701 889
TR4	4 Boiler back-to-back cascade set with insulation	7 736 701 890
TR5	5 Boiler back-to-back cascade set with insulation	7 736 701 891
TR6	6 Boiler back-to-back cascade set with insulation	7 736 701 892

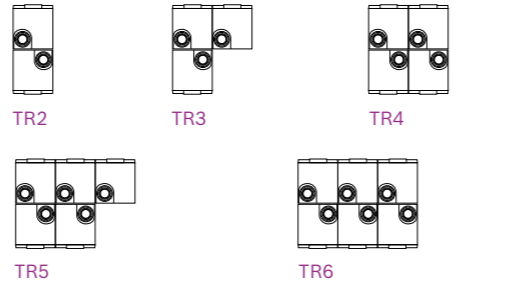

4 Victaulic connections

Only required when **NOT** using a Bosch specified low loss header. If using a low loss header skip to 6.

Cascade setup	Description	Part number
TL1	Victaulic 2.5" to flange connection DN65 PN6 (Pack Qty. 2)	7 736 701 914
TL2/TR2		
TL3/TR3	Victaulic 4" to flange connection DN100 PN6 (Pack Qty. 2)	7 736 701 913
TL4/TR4		
TL5/TR5		
TL6/TR6		

Boiler configurations

Cascade with plate heat exchanger or low loss header

A plate heat exchanger can be used to separate the boiler from the system in both open vented and sealed systems. This provides greater protection for the boiler, especially where the water quality in the existing system is poor.



A low loss header is a device that hydraulically separates the boiler from the heating circuit. This helps to improve the efficiency and performance of the heating system by regulating the pressure and flow rate of the system.



5 Plate heat exchangers

Description	Part number	PHE connection type
50KW Plate heat exchanger	7 733 600 013	1 ¼" Male BSPP flat face
65KW Plate heat exchanger	7 733 600 014	1 ¼" Male BSPP flat face
80-100KW Plate heat exchanger	7 733 600 016	1 ¼" Male BSPP flat face
101-140KW Plate heat exchanger	7 733 600 017	2" Male BSPP flat face
141-180KW Plate heat exchanger	7 733 600 018	2" Male BSPP flat face
181-230KW Plate heat exchanger	7 733 600 020	2" Male BSPP flat face
231-280KW Plate heat exchanger	7 733 600 021	2 ½" Male BSPP flat face
281-400KW Plate heat exchanger	7 733 600 023	2 ½" Male BSPP flat face
401-520KW Plate heat exchanger	7 733 600 025	2 ½" Male BSPP flat face
521-640KW Plate heat exchanger	7 733 600 026	2 ½" Male BSPP flat face
641-860kW Plate heat exchanger	7 733 600 027	DN100 compact flange

6 Low loss header

Cascade Setup	Description	Part number	Optional flanges	Part number
TL1	Low loss header + Insulation 300kW	7 736 701 907	Threaded flange DN65 PN6	7 736 700 487
TL2/TR2				
TL3/TR3	Low loss header + Insulation 900kW	7 736 701 908	Threaded flange DN100 PN6	7 736 700 964
TL4/TR4				
TL5/TR5				
TL6/TR6				

7 Controls

Bosch intelligent controls	Part number
8313 Control	7 736 602 245
Temperature sensor set EMS plus 200mm	7 735 600 656
FM-CM Module (cascade sequencer)	7 736 602 098
FM-MM Module (2 heating circuits)	8 718 598 828
FM-MW Module (1 heating, 1 hot water circuit)	8 718 598 831

Bosch sequencing controls	Part number
MC400 Cascade sequencer	7 738 111 001
Temperature sensor set TF HW EMS2 200mm (MC400 required accessory)	7 735 600 657
MM100 Zone control module	7 738 110 140
Greenstar Sense II (interface controller, MM100 required accessory)	7 738 111 064

BMS integration	Part number
MU100 Programmer (BMS interface module)	7 738 110 145

Condens 7000 WP accessories



Pressure relief valve 4 bar

7-095-595

4 bar pressure relief valve for installation in the Condens 7000 WP pump group.



Pressure relief valve 6 bar

7-736-700-914

6 bar pressure relief valve for installation in the Condens 7000 WP pump group.



Non-return valve - return pipe

7-736-700-432

(Included in hydraulic frame kit)

DN32 non-return valve. For Condens 7000 WP installations not using the Bosch hydraulic cascade kit.



Connection set (hydraulic TL)

7-736-702-047

(Included in hydraulic frame kit)

Connection set for hydraulic cascade Condens 7000 WP boilers in a line (TL set up).



Connection set (hydraulic TR)

7-736-702-048

(Included in hydraulic frame kit)

Connection set for hydraulic cascade Condens 7000 WP boilers in a back-to-back configuration (TR set up).



Connection set (gas TL)

7-736-701-870

(Included in hydraulic frame kit)

Gas connection set from pump group to gas manifold. Front boiler assembly for Condens 7000 WP boilers in a line (TL set up).



Connection set (gas TR)

7-736-701-872

(Included in hydraulic frame kit)

Gas connection set from pump group to gas manifold. Front boiler assembly for Condens 7000 WP boilers in a back-to-back set up (TR set up).



RTH converter

7-807-9

RTH converter to enable the use of third party 230Vac controls. Included as standard with the 50 and 65kW models.



TL1 boiler frame set w. insul wo Gas

7-736-701-882

Single hydraulic frame kit (TL1 set up) with insulation for use with the Condens 7000 WP boiler. Includes frame kit, insulation, hydraulic headers and connection set (without gas header).



TL1 basic boiler frame set

7-736-701-912

Single frame kit (TL1 set up) with insulation for use with the Condens 7000 WP boiler. Includes frame kit and insulation only.



Flange connection 2.5" incl. victaulic

7-736-701-914

Hydraulic connections from victaulic 2.5 inch to flange DN65, PN6 for the Condens 7000 WP hydraulic cascade kits. Please specify this when using the cascade kit without low loss header or when using plate heat exchangers (pack of 2).



Flange connection 4" incl. victaulic

7-736-701-913

Hydraulic connections from victaulic 4 inch to flange DN100, PN6 for the Condens 7000 WP hydraulic cascade kits. Please specify this when using the cascade kit without low loss header or when using plate heat exchangers (pack of 2).



Gas cock

7-736-701-868

(Included in pump group) Gas isolating valve for Condens 7000 WP pump group.



Victaulic coupling 2.5"

7-736-701-915

Victaulic coupling 2.5 inch (pack of 1).



Victaulic coupling 4"

7-736-701-916

Victaulic coupling 4 inch (pack of 1).



AS/HKV 32 connection set

5-584-552

Connection set for when using a pump group without hydraulic cascade kit (1 1/4 inch).

Training

Install with confidence

Learn all you need to know about the Condens 7000 WP commercial boiler range. We specifically tailor all our product courses to meet your needs. This hands-on course is perfect for those who want to specify and install the Condens 7000 WP boilers for commercial and domestic applications.

Supporting you

Our courses are here to support your installation from beginning to end. The Condens 7000 WP course covers:

- ▶ Specification and installation
- ▶ Service and maintenance
- ▶ Fault finding and diagnostics

Our product training courses will help you get hands-on experience and understand all the features and benefits.



Scan to start your training:

worcester-bosch.co.uk/eacademy

Get in touch

Sales

Tel: 03330 608 456

Email: commercial.industrial@uk.bosch.com

Technical Helpline

Tel: 0330 123 0165

Email: technical-advice@uk.bosch.com

Controls Helpline

Tel: 0330 123 3641

Training

Tel: 0330 123 0166

Email: training@uk.bosch.com

Bosch Commercial and Industrial

Cotswold Way, Warndon, Worcester. WR4 9SW

[bosch-industrial.co.uk](https://www.bosch-industrial.co.uk)

Share

We would love to see your installations!



Bosch Commercial Industrial



Bosch Industrial UK

Calls to and from Bosch Thermotechnology Ltd may be recorded for training and quality assurance purposes. This brochure is accurate at the date of printing, but may be superseded and should be disregarded if specification and/or appearances are changed in the interest of continued improvement. The statutory rights of the consumer are not affected.

