

**Recycling**



This product should not be disposed of with household waste. Please recycle the products where facilities for electronic waste exist. Check with your local authorities for recycling advice.

CONFORMS TO THE ESSENTIAL REQUIREMENTS OF THE FOLLOWING DIRECTIVE

- Relevant EU Directives:
- 2014/30/EU – Electromagnetic compatibility
  - 2014/35/EU – Low voltage directive
  - 2011/65/EU – RoHS directive
  - 2012/19/EU – WEEE directive

Standards: EN60730-1; EN60730-2-7; EN60730-2-9



**ATAG**

ATAG Heating Technology Ltd  
80 Churchill Square Business Centre  
Kings Hill  
West Malling  
Kent  
ME19 4YU

Technical Tel: 0800 254 5065  
Email: technical@atagheating.co.uk  
Website: www.atagheating.co.uk

**ATAG**

**2 Port (22mm) Twin Zone System Control Pack with LWC 1 Wiring Centre**

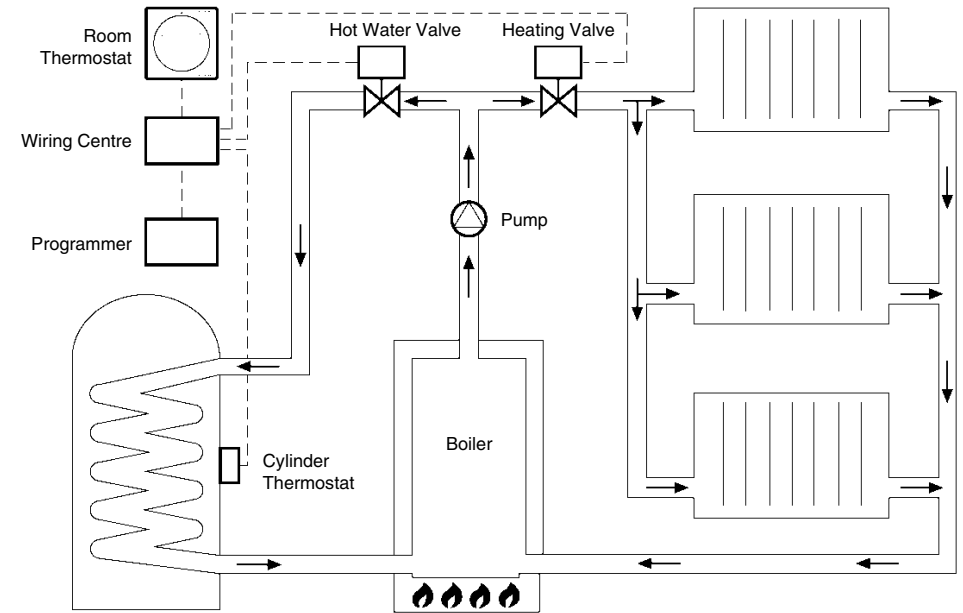

**INSTALLATION AND WIRING GUIDE**

**CONTENTS**

- Programmer
- Zone Valve Heating
- Zone Valve Hot Water
- Room Thermostat
- Cylinder Thermostat
- LWC 1 Wiring Centre

# INSTALLATION INSTRUCTIONS

## PROGRAMMER

Please refer to separate leaflet.

## ROOM THERMOSTAT

Please refer to separate leaflet.

## MOTORISED VALVE

### Installation

Install the valve in a clean, dry location where the ambient temperature does not exceed 52°C. Ensure that the motor housing is not below the valve body. The manual lever and motor cover retaining-screw should be left accessible and the position indicator visible. Cut connecting copper tubes to allow 10-15mm penetration (22mm valve) or 22-25mm penetration (28mm valve) into the valve body, and ensure tube ends are square and free of burrs. Slip the compression nuts over the ends of the tubes, followed by the copper olives so that these fit within the threaded sections of the nuts. Offer up to the valve body, screw on and tighten the compression nuts by hand until finger tight and then tighten fully using suitable spanner or adjustable wrench. Care must be taken not to over tighten or to put any mechanical force on the plastic parts of the valve.

### Fitting/Removing Actuator

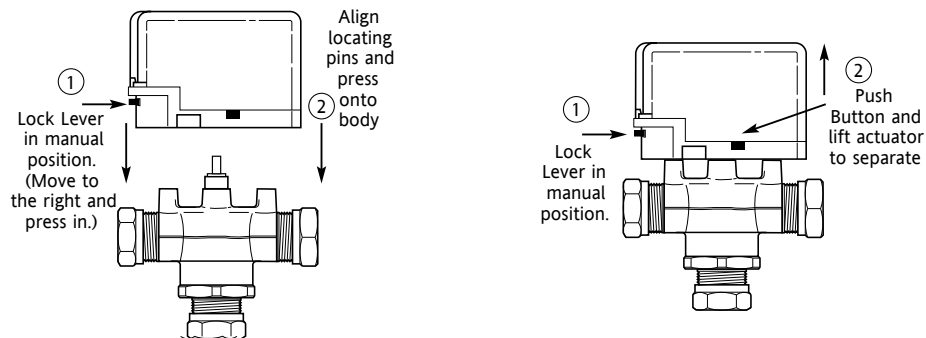

### Minimum Clearances

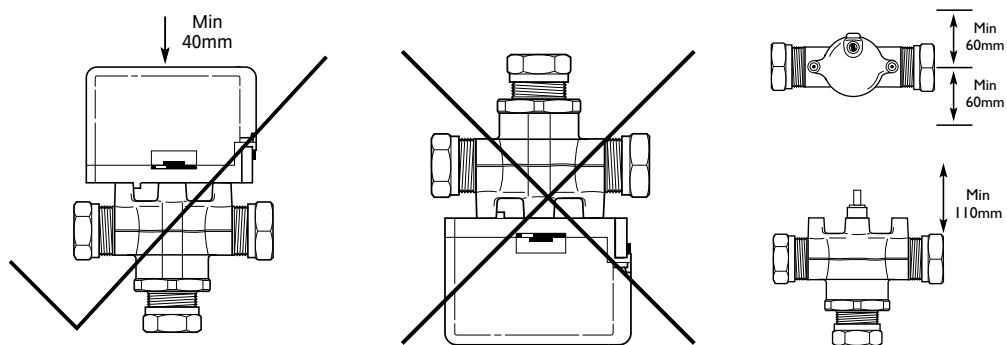

## OPERATION

Two port valves are supplied *normally* closed, i.e. they have to be powered to open. They spring return to the closed position when the power is removed. Flow direction should be in through Port 'A' and out through Port 'B'.

## MANUAL LEVER

The manual lever is used when filling, venting and draining the installation. To open the valve, the manual lever should be moved from left to right across the valve and then pressed in. When released it will lock in this position. It automatically releases when power is applied to the valve.

## VALVE POSITION INDICATOR

A = valve closed B = valve open

## CYLINDER THERMOSTAT

### Positioning

The HTS3 should be installed approximately one third of the way up the hot water cylinder, and at the front for ease of access. With pre-insulated cylinders, mark the position and size, and remove just enough insulation to allow the HTS3 to fit against the metal of the cylinder in the recess formed.

The base of the HTS3 should be held in good contact with the metal of the hot water cylinder.

The plastic covered spring fixing cable should be cut to an unstretched length of approximately 2 1/2" - 3" less than the circumference

of the cylinder and the hook and eyelet screwed into the ends. Stretch the cable round the cylinder, above the insulation, and position it in the groove across the front of the HTS3. Engage the hook and eyelet.

### Commissioning

The two setting marks outside the temperature scale on the HTS3 provide positive ON and OFF positions to assist with commissioning or checking the system operation. Rotate the setting arrow fully clockwise for ON, and anticlockwise for OFF.

### Setting

With a screwdriver, position the setting arrow at the desired nominal hot water temperature. A popular setting is 60°C but if this is not exactly suitable, simply adjust up or down as appropriate.

### Frost Protection

If frost protection is required, we recommend that a frost thermostat (RTS3) is fitted in series with a pipe thermostat (PTS1) to provide 'Two Stage' protection.

## ZONE VALVE Systems with LWC1 Wiring centre

### Wiring Centre - BASIC LINK

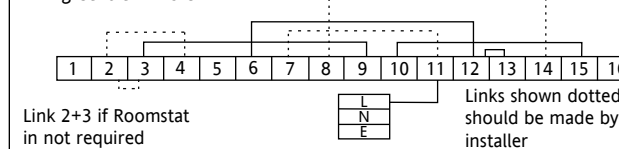

### CONNECTIONS

The numbers printed at the tip of each arrow represent the Wiring Centre Terminals to which those leads or terminals should be connected.

### Pump

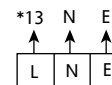

### Boiler

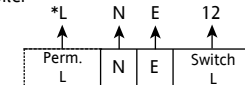

\* Refer to Boiler Handbook for wiring details of Pump Overrun boilers. Use boiler manufactures instructions.

### Controls

#### Room Thermostat

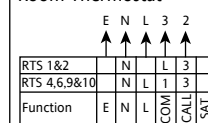

#### Cyl. Thermostat

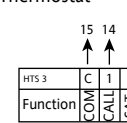

#### Programmer

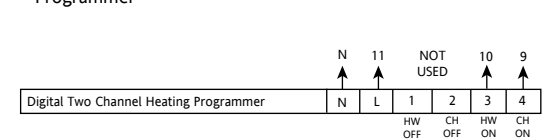

### Mains Input 230V 50HZ

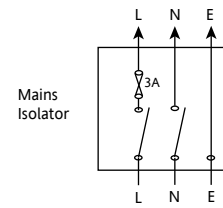

### Motorized Valves

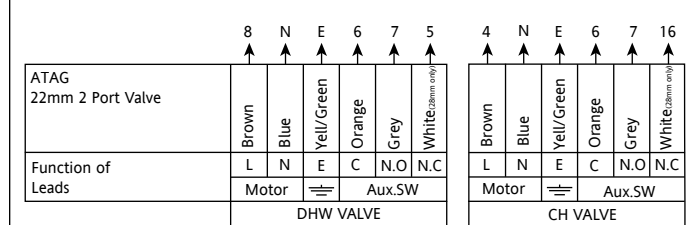

The white wire (28mm Valves) becomes live when the valve closes, it is not used and is wired to 'spare' terminals for sale isolation.

Every effort has been made to simplify the instructions and to ensure accuracy. However, the information is provided for guidance only and ATAG are unable to accept liability for incorrect installation.

WHERE ANY DOUBT EXIST, PLEASE SEEK PROFESSIONAL ADVICE