



# Installation & Maintenance Instructions



**The Electric Heating Company Ltd**  
Unit 40 Block 5 Third Road  
Blantyre Industrial Estate  
Blantyre Glasgow  
G72 0UP  
Tel: 01698 820533  
Fax: 01698 825697  
email: [info@electric-heatingcompany.co.uk](mailto:info@electric-heatingcompany.co.uk)

CODE: 026651



## CONTENTS

3	Your cylinder and its components
4-5	Preparing to install the cylinder
6-9	Installation instructions
10	Product specification details
11-14	Product diagrams, connections & measurements
14-15	Schematic wiring diagrams
16	Commissioning and decommissioning
17	Servicing instructions and fault-finding
18	Information for homeowners
19	Commissioning record
20-25	Service history
26-28	Guarantee and product registration

See insert sheet for product-specific technical performance, specification details and lists of spare parts and approvals.

## INTRODUCTION

The EHC Neptune Unvented cylinder is made from Duplex Stainless Steel for excellent corrosion resistance. The EHC Neptune has a strong rust-resistant steel case and is highly insulated with environmentally friendly foam.

The EHC Neptune is supplied complete with all the necessary safety and control devices needed to connect to the cold water mains. All are pre-adjusted. High quality controls have been selected to combine high flow rate performance with minimum pressure drop to make the EHC Neptune perform well in all areas, even those with poor water pressure.

## IMPORTANT NOTE TO THE INSTALLER



Read these instructions before commencing installation. Unvented cylinders are a controlled service as defined in the latest edition of the building regulations and should only be fitted by a competent person.

You must ensure the installation complies with the current Building Regulations and or Technical Standards Documents for England, Scotland, Wales, N Ireland or Ireland.

After installation the Commissioning Checklist on page 19 must be completed and left, with these instructions, with the householder for future reference.

## IMPORTANT NOTE TO THE HOMEOWNER



Please ensure that the installer has fully completed the Commissioning Checklist on page 19 of this installation manual. You will need this information should you need to make a claim against your product guarantee in the future.

This product requires servicing every 12 months and the Service Record must be maintained to protect your 25-year guarantee

Please note all images are for illustrative purposes only and specific products will vary for each product line.

# YOUR CYLINDER AND ITS COMPONENTS

## YOUR CYLINDER AND ITS COMPONENTS

The unvented cylinder comes complete with the necessary fittings, safety and control devices needed to connect to the cold water mains. All have been pre-adjusted. High quality controls have been selected to combine high flow rate performance with minimum pressure drop to make the unvented cylinder perform well in all areas, even those with poor water pressure. See insert sheet for a list of spare parts.

## TABLE OF COMPONENTS

All cylinders are supplied with installation and maintenance instructions, an inlet control set, a temperature and pressure relief valve, an acetald tundish and an external expansion vessel, for a full list of spare parts codes please refer to the technical performance and specification insert sheet.

Some products are fitted with a smart immersion heater, see the specification insert sheet for details or see the inside of the immersion heater cap to determine which type your product has.

If the water quality is aggressive (max chloride 250mg/l) we recommend exchanging the immersion heater for a titanium element and an electrolytic scale reducer.



**Table 1:** Supplied components

	Inlet Control Set	Temperature Pressure Relief Valve	Tundish	External Expansion Vessel - DHW	Room Thermostat	2 Channel Programmer	3 Channel Programmer	Robo-kit including Heating Expansion Vessel	Sensor Pocket Retaining Bungs	Single High Limit Thermostat	Dual Thermostat 1 Zone Heating	Two-Port Valve	Immersion Heater
Direct Models (Electric) and Slimline Direct Models (Electric)	⊙	⊙	⊙	⊙									⊙
Indirect Pre-Plumb Models – 1 Zone	⊙	⊙	⊙	⊙	⊙	⊙		⊙	⊙		⊙	⊙	⊙
Slimline Indirect Pre-Plumb Models – 1 Zone	⊙	⊙	⊙	⊙	⊙	⊙		⊙	⊙		⊙	⊙	⊙
Indirect Pre-Plumb Models – 2 Zone	⊙	⊙	⊙	⊙	⊙		⊙	⊙	⊙		⊙	⊙	⊙
Indirect Models and Slimline Indirect Models	⊙	⊙	⊙	⊙							⊙	⊙	⊙
Solar Indirect Models	⊙	⊙	⊙	⊙					⊙	⊙	⊙	⊙	⊙



# PREPARING TO INSTALL THE CYLINDER

## STORAGE PRIOR TO INSTALLATION

The unvented cylinder should be stored in its original packaging in an upright position in an area free from excessive moisture.

## HANDLING PRODUCT

The unvented cylinder should be carried upright where possible. Assessments of risks for carrying the cylinder should be conducted. Use more than one person for carrying where appropriate. Never carry the cylinder using the pre-plumbed pipework or components. Always follow latest guidelines for lifting techniques, to avoid injury, or damage to the product.

## WATER SUPPLY

The unvented cylinder operates at 3 bar (controlled by the inlet control set) and is capable of delivering over 50 litres per minute. The high quality inlet control set has been designed to make the most of the flow rates available, however the performance of any unvented system is only as good as the mains water supply. The maximum possible water demand should be assessed, taking into consideration that both hot and cold services are supplied simultaneously from the mains.

The water supply should be checked to ensure it can meet these requirements. If necessary, consult the local water company regarding the likely pressure and flow rate availability.

If measuring the water pressure, note that a high static (no flow) mains pressure is no guarantee of good flow availability. In a domestic installation 1.5 bar and 25 l/min. should be regarded as the minimum. The maximum mains pressure that the inlet control set can accept is 12 bar.

Consideration should be given to upgrading existing 1/2" (15mm) cold mains pipework to a larger size if the recommended minimum pressure/flow rate is not being achieved.

## ELECTRICITY SUPPLY

The unvented cylinder requires 240 Volt electrical supply for the immersion elements. The electrical supply to each immersion heater must be fused at 13A via a double pole isolating switch that meets the current BS Standards. The cable must be at least 2.5mm<sup>2</sup> heat resistant (85°C HOFR) sheathed flex complying to the current BS Standards

## SITING THE UNIT

The unvented cylinder can supply outlets above it or at some distance from it. Site the unit to minimise "dead leg" distances, especially to the point of most frequent use.

Outlets above the unvented cylinder will reduce the outlet pressure available by 0.1 bar for every 1m of height difference. The unit should be protected from frost. Particular care is needed if siting in a garage, outbuilding or loft space. All exposed pipework should be insulated. The unvented cylinder must be installed in the correct orientation i.e. vertically (unless you're using a horizontal model), on a flat base capable of supporting the weight of the cylinder when full. See technical specification insert sheet for weights. The minimum recommended cupboard size for vertical models is 750mm square.

## Access

Consideration should be given to the position of discharge pipes (tundish) drain valves. Avoid positioning these too close to electrical devices and components. Also allow sufficient space so that the cylinder can be inspected, maintained and serviced in the future.

The immersion heaters are 400mm long and care should be taken to ensure that they can be withdrawn, enabling the immersion heater to be replaced at the end of its working life and providing inspection access to the interior of the cylinder in servicing if required.

The discharge pipework from the safety valves should fall continuously and terminate safely.

## VERTICAL UNIT

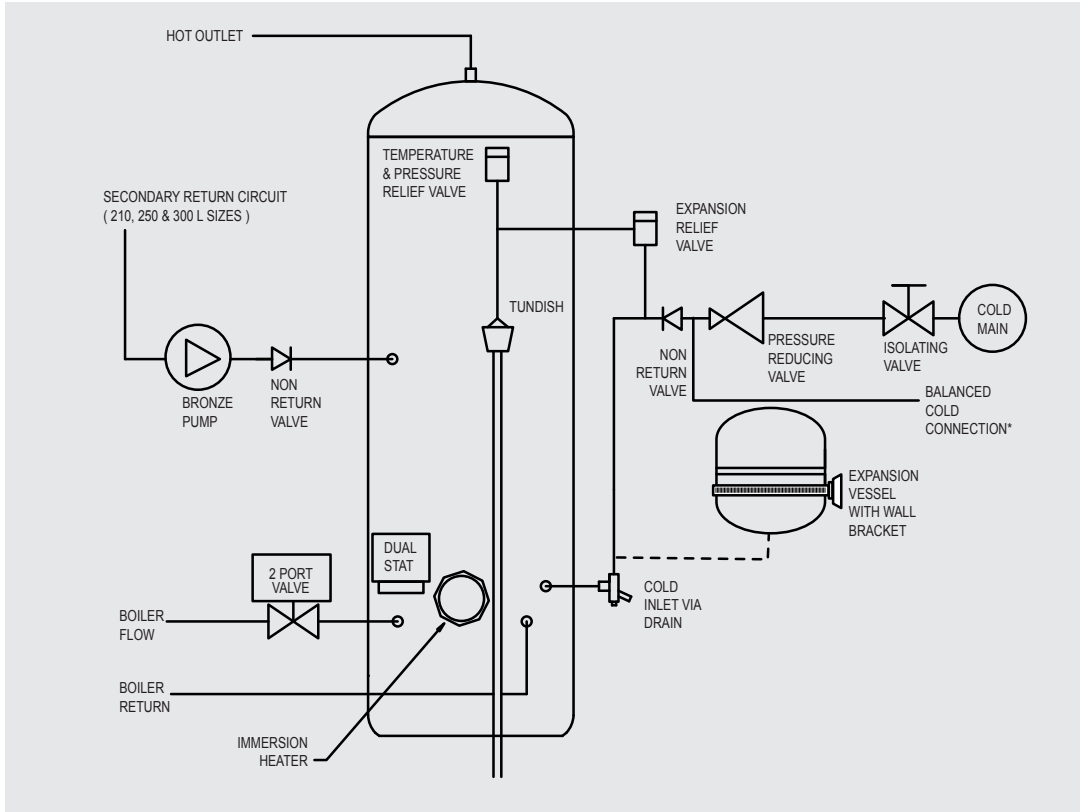

### Notes:

The pressure reducing valve, non-return valve and expansion relief valve are combined together in the inlet control set.

On 120 – 180 litre sizes there is no dedicated secondary return boss and the secondary return circuit should be tee'd into the cold feed pipe just above the drain elbow.



# INSTALLATION INSTRUCTIONS

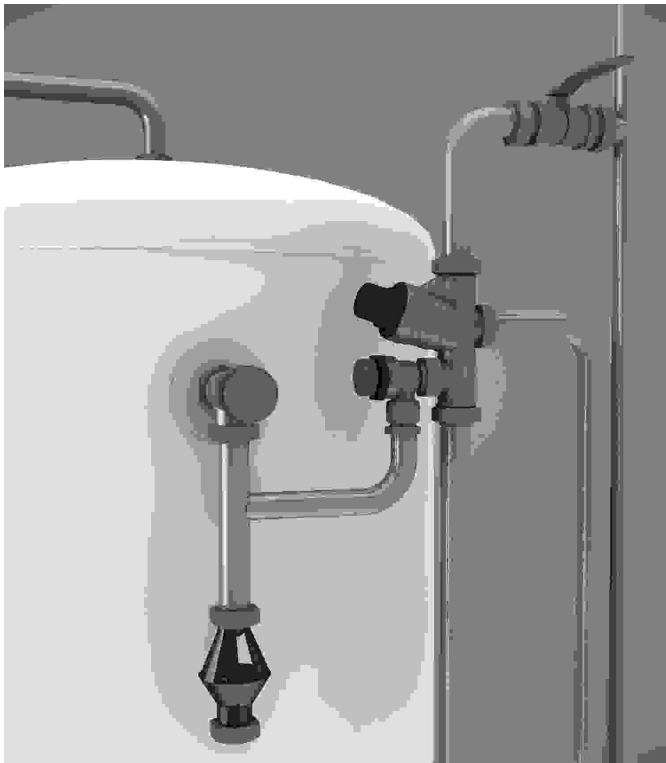

## COLD MAINS PIPEWORK

Run the cold mains through the building to the place where the unvented cylinder is to be installed. Take care not to run the cold pipe near hot water or heating pipework so that the heat pick-up is minimised. Identify the cold water supply pipe and fit an isolating valve (not supplied).

We recommend using a full bore 22mm quarter turn ball valve, alternatively a 22mm stopcock can be used, however this may reduce the flow rate. **Do not** use a “screwdriver slot” or similar service valve.

For pre-plumbed units simply make the connection to the inlet control set (Position A Page 11). For standard models make the connection to the cold feed of the cylinder and incorporate a drain valve. Position the drain valve no higher than the cold inlet to ensure sufficient draining of the cylinder when required. Position the inlet control just **above** the Temperature & Pressure Relief Valve (TPRV) mounted on the side of the cylinder. This ensures that the cylinder does not have to be drained down in order to service the inlet control set. Ensure that the arrow points in the direction of the water flow.

Select a suitable position for the expansion vessel. Mount it to the wall using the bracket attached to the vessel. Use suitable fittings capable of supporting full vessel weight (and with appropriate consideration to wall material). Connect the expansion vessel to the cold feed pipework between the inlet control set and the cold inlet on the cylinder. Ensure that the top of the vessel is accessible for servicing.

## Connecting to the cylinder

All of the pipework connections on the cylinder are 22mm compression and supplied complete with gland nuts and olives, in the Accessory Kit box. Only connect 22mm BS EN1057-R250 copper tube to these connections.

Cut the tube square using a rotary tube cutter and ensure no sharp edges or burrs protrude. Slide both gland nut and olive onto the tube and push tube fully home into the connection, ensuring the tube end fully bottoms on the connection recess. Smear the outer wall of the olive with plumbing paste and tighten the gland nut in the prescribed manner. Upon filling/commissioning, ensure all connections are completely watertight, including immersion bosses and any pre-plumbed pipework if applicable.

**Note:** No control or isolation valve should be fitted between the expansion relief valve and the storage cylinder. The relief valve connections should not be used for any other purpose.

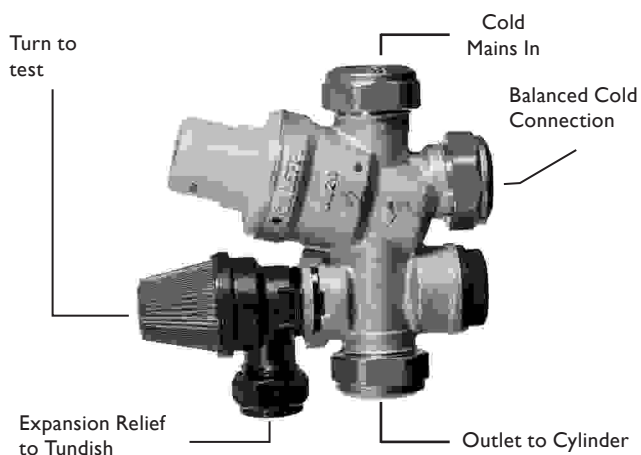

# INSTALLATION INSTRUCTIONS (CONTINUED)

## BALANCED CONNECTIONS

Where there are showers, bidets or monobloc mixing taps in the installation, these should be installed to comply with the Water Supply (Water Fittings) Regulations 1999.

If these devices have un-balanced supplies there should be single check valves installed at both inlets, to stop over-pressurisation of either supply. A balanced cold supply is necessary.

On some cylinder models the inlet control set, features a 22mm balanced cold connection, refer to the spare parts list on the insert sheet for details. This connection must be capped off if not used.

## HOT WATER PIPEWORK

Run the first part of the hot water distribution pipework in 22mm.

This can be reduced near to the outlet to 15mm or 10mm if appropriate, for example to suit the type of tap. You should aim to keep the run length of any hot water pipework from the cylinder to outlet to a practical minimum so the time taken for the hot water to reach the outlet is as quick as possible.

Then connect the hot water pipework to the hot water draw-off on the cylinder (Position B in the diagrams on pages 11-14).

## CONNECTIONS FOR INDIRECT UNITS

For Solar input models refer to the shaded box before making any connections.

Connect the primary connections using the compression connections provided. The primary circuit must be positively pumped. Gravity circulation is not suitable.

Either primary connection may be used as the primary flow, reheat times are not affected. The primary circuit can be open vented or sealed, up to a maximum pressure of 3.5 bar. If you seal the primary circuit an additional expansion vessel and safety valve is required.

Connect the two port valve into the primary flow pipework. The direction of the flow arrow should be towards the primary flow connection.

Where connecting to a boiler, the boiler can be Gas, Electric or Oil, but must be under effective thermostatic control. Uncontrolled heat sources such as some AGAs, back boilers, solid fuel stoves, etc. are not suitable. Please contact our Technical department for guidance.

On pre-plumbed models (page 11), connect to the boiler flow and return Positions F & G, for single zone heating systems connect the radiator circuit to Positions H & J and with twin zone heating systems connect the second zone to Positions I & J. Note, pre-plumbed models are supplied with an additional expansion vessel and safety valve for the heating circuit. Consult the boiler manufacturer's instructions to confirm sizing is suitable for the heating system and guidance on positioning.

## SOLAR INDIRECT UNVENTED (TWIN COIL)

### Upper coil

The upper coil is connected to the fossil fuel boiler as per the instructions for the unvented indirect single coil model, with the dual stat control and high limit thermostat inserted into pocket G2 (boiler) or Pocket G1. The wiring requirements are shown on page 14.

### Lower coil: solar installation

The flow and return from the solar heat source are to be connected to the bottom coil. Either primary coil connection may be utilised as the flow or return. The solar primary circuit must have its own dedicated circulating pump, thermal and safety controls, which must be installed as per the solar manufacturer's instructions. The solar control system used must be of the solar differential control type and should be connected to the solar sensor.

The solar sensor, supplied as part of the solar controls should be inserted into Pocket G1 (boiler) and is held in-situ with the black sensor pocket retaining bung provided.

It is necessary to connect the solar pump via the overtemperature high limit cut-out (provided) to ensure the heat input to the solar coil is interrupted if the cylinder overheats. Some method to prevent thermosyphoning must also be employed. Non-return check valves in the primary flow and return pipework would be acceptable. If solar controls do not offer appropriate isolation, a two port zone valve (not supplied) can be used with the pump and high limit stat as shown on page 14.

**Note:** If it is intended to fit a cylinder with a solar coil to be used at a later date, the two coils should be connected in series to make use of the solar coil, using the dual stat in Pocket G2 (boiler), as shown in the diagram on page 14.

The Domestic Heating Compliance Guide document LIA and LIB provides excellent advice in sizing both cylinder dedicated solar areas and heat exchangers to the surface area of the solar collectors. Using this guide we are able to offer sizing advice for specification.

**Note:** Consult all details of the compliance guide documentation prior to specifying product or commencing design.



# INSTALLATION INSTRUCTIONS (CONTINUED)

## SECONDARY CIRCULATION CONNECTION

This can be used with secondary circulation. An appropriate WRAS approved bronze or stainless steel circulator should be used in conjunction with a non-return valve to prevent backflow.

On large secondary circulation systems it may be necessary to incorporate an extra expansion vessel into the circuit to accommodate the increased system water volume. Secondary circulation should be minimised or avoided on Direct electrically heated units, especially if the unit is being used on an off-peak electricity tariff.

A secondary return boss is fitted as standard on 210, 250 & 300 ltr units. On smaller sizes, use a swept tee to connect into the cold feed pipe above the drain.

## IMMERSION HEATERS

Only immersion heaters with a thermal cut-out that comply with BS EN 60335-2-73 may be used. To help ensure this, the immersion heaters have a special 1 3/4" thread. They are rated at 3kW at 240V and are of a low noise Incoloy construction.

They have both a thermostat and a high limit cut-out. Please order the correct replacement via ourselves; fitting non-approved immersions may affect your guarantee. When fitting, ensure the 'O' ring is positioned correctly on the head of the immersion heater and lubricate before fitting. Fit it by hand until almost home then tighten gently, as the 'O' rings will seal easily. Electrical supply refer to page 4.

Do not operate the immersion heater/s until the cylinder is full of water.

Do not operate the immersion heater/s if any sterilisation liquid is in the cylinder as this will cause premature failure.

If the water quality is aggressive (max chloride 250mg/l) we recommend exchanging the immersion heater for a titanium element and an electrolytic scale reducer.

**Note:** Immersion heaters should never be used as the primary heat source except for the lower immersion on a direct cylinder.

Selected cylinder models feature a smart control, fitted to the lower immersion heater. See insert sheet for details.

## ELECTRICAL CONNECTIONS

Complete the wiring – use the appropriate wiring diagrams on pages 14-15.

## DISCHARGE ARRANGEMENT

For pre-plumbed models, you simply need to connect 22mm discharge pipe to the tundish and then route the discharge pipe as explained below. For non pre-plumbed cylinders you will need to position the inlet control group so that the discharge from both safety valves can be joined together via a 15mm tee (see diagram below). Connect the tundish and then connect and route the discharge pipe.

Ensure all pipes to and from the tundish are cut square, are free from burrs or damage, and that the tundish if fitted vertically.

The discharge pipework must be routed in accordance with Part G3 of schedule 1 of the Building Regulations. The information that follows is not exhaustive and if you are in doubt you should seek advice.

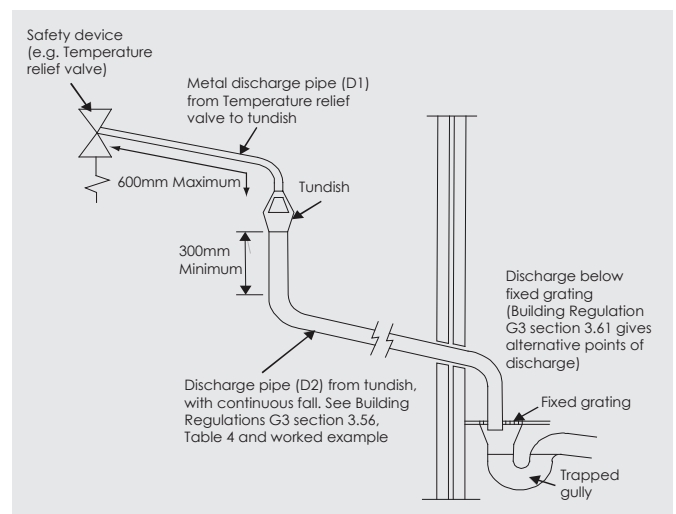

**Note:** The discharge will consist of scalding water and steam. Asphalt, roofing felt and non-metallic rainwater goods may be damaged by such discharges.

**Note:** Although building regulations now permit the D2 pipe from the tundish to be installed in soil stacks within premises, we do not recommend this, as discharge from the temperature and pressure valve may continue for long periods of time. It is the installer's responsibility to ensure the discharge pipework can support the discharge for prolonged periods. If used, follow the guidance given in the G3 Building Regulations (mechanical seal without water trap). As discharge can be in excess of 90°C, discharge into plastic pipework is also not recommended.



# INSTALLATION INSTRUCTIONS (CONTINUED)

The two safety valves will only discharge water under fault conditions. When operating normally water will not be discharged. The tundish should be located in the same space as the unvented hot water storage system and be fitted as close as possible to, and lower than, the safety device, with no more than 600mm of pipe between the valve outlet and the tundish. The tundish should be positioned away from electrical devices.

Any discharge should be visible at the tundish. The tundish should be located such that any discharge is visible. In addition, where discharges from safety devices may not be apparent, extra consideration should be given, e.g. for people with impaired vision or mobility. This could be via the installation of a suitable electronically operated or other safety device to warn when discharge takes place.

The discharge pipe (D2) from the tundish should:

- A) Have a vertical section of pipe at least 300mm long, below the tundish before any elbows or bends in the pipework.
- B) Be installed with a continuous fall of at least 1 in 200 thereafter.

The discharge pipe (D2) from the tundish should be of metal or other material that has been demonstrated to be capable of withstanding temperatures of the water discharged.

The discharge pipe (D2) should be at least one pipe size larger than the nominal outlet size of the safety device, unless its total equivalent hydraulic resistance exceeds that of a straight pipe 9m long. Therefore, discharge pipes between 9m and 18m equivalent resistance length should be at least two sizes larger than the nominal outlet size of the safety device; between 18 and 27m at least three sizes larger. Bends must be taken into account in calculating the flow resistance. Refer to the diagram, Table 2 and the worked example.

An alternative approach for sizing discharge pipes would be to follow BS EN 806:2 specifications for design, installation, testing and maintenance of services supplying water for domestic use within buildings and their curtilages.

The discharge pipe (D2) should terminate in a safe place where there is no risk to persons in the vicinity of the discharge. Examples of acceptable discharge arrangements are:

- A) To a trapped gully with the end of the pipe below the fixed grating and above the water seal.
- B) Downward discharges at a low level; i.e. up to 100mm above external surfaces such as car parks, hard standings, grassed areas etc. are acceptable, providing that – where children play or otherwise could come into contact with discharges – a visible wire cage or similar guard is positioned to prevent contact.
- C) Discharges at a high level; e.g. into a metal hopper and metal down pipe with the end of the discharge pipe clearly visible; or onto a roof capable of withstanding high temperature discharges of water and 3m from any plastic guttering systems that would collect such discharges.
- D) Device to warn when discharge takes place.

### Discharge worked example

The example below is for G1/2 temperature relief valve with a discharge pipe (D2) having four elbows and a length of 7m from the tundish to the point of discharge.

Maximum resistance allowed for a straight length of 22mm copper discharge pipe (D2) from a G1/2 temperature relief valve is: 9.0m.

Subtract the resistance for four 22mm elbows at 0.8m each = 3.2m.

Therefore the maximum permitted length equates to: 5.8m.

5.8m is less than the actual length of 7m, therefore calculate the next largest size.

Maximum resistance allowed for a straight length of 28mm pipe (D2) from a G1/2 temperature relief valve equates to: 14m.

As the actual length is 7m, a 28mm (D2) copper pipe will be satisfactory.

**Table 2:** Sizing of copper discharge pipe 'D2' for a temperature relief valve with a G1/2 outlet size (as supplied).

Size of discharge pipework	Maximum length of straight pipe (no bends or elbows)	Deduct the figure below from the maximum length for each bend or elbow in the discharge pipe
22mm	Up to 9m	0.8m
28mm	Up to 18m	1.0m
35mm	Up to 27m	1.4m



# SPECIFICATION DETAILS

The unvented cylinder is made from Duplex stainless steel for excellent corrosion resistance. The cylinder has a strong rust-proofed steel case and is highly insulated with environmentally-friendly foam. Further details are below.

## MATERIALS

- Inner shell – Duplex stainless steel
- Coil – 22mm diameter stainless steel
- Bosses – Stainless steel
- Polyurethane CFC- and HCFC-free foam insulation. This insulation has an Ozone Depletion Potential of Zero and a Global Warming Potential of 3.1.
- Casing – galvanized steel, durable finish
- Anode – none fitted/required

All cylinders are welded using our advanced TIG welding production methods, under a controlled oxygen purged process, to maximize the corrosion resistant qualities of the high-grade Duplex stainless steel. Every cylinder is checked using 15 bar pressure testing.

## IMMERSION HEATER

- 1 3/4" BSP parallel threaded head
- Long life incoloy sheathed low noise element and thermostat pocket
- Brazed construction
- Combined thermostat and safety cut-out
- Element rating 3kW at 240V A/C

Smart control fitted to the lower immersion heater on selected models only, please refer to insert sheet for details.

## GUARANTEE

The inner cylinder carries a 25-year guarantee against faulty materials or manufacture on indirect and direct models. All parts supplied with the cylinder carry a 2-year guarantee. All guarantees must be registered at [www.electric-heatingcompany.co.uk/warranty-registration/](http://www.electric-heatingcompany.co.uk/warranty-registration/) or by completing and returning the guarantee card on page 28.

## FLOW RATES

Our cylinders are renowned for their fast flow rates. The graph on the insert sheet illustrates the speed at which hot water can be distributed reliably throughout the home.

**Table 3:** Pressure specifications

<b>Maximum Inlet Water Pressure</b>	12.0 bar
<b>Operating Pressure/Maximum Design Pressure</b>	3.0 bar
<b>Expansion Valve Opening Pressure</b>	6.0 bar
<b>Expansion Vessel Charge Pressure</b>	3.0 bar
<b>Maximum Operating Pressure</b>	7.0 bar
<b>Opening Pressure of T &amp; P Valve</b>	7.0 bar
<b>Opening Temperature of T &amp; P Valve</b>	90°C
<b>Maximum Pressure on Primary Circuit (Indirect or Solar Coil)</b>	3.5 bar

**Table 4:** Immersion element specifications

<b>Element Rating</b>	3kW 240V
<b>Thread Type</b>	1 3/4" BSP
<b>Fuse Requirement</b>	13A via Double Pole Switch
<b>Control Thermostat for Element Temperature Range</b>	45°C - 65°C
<b>High Limit Thermostat for Element Temperature Set Point</b>	85°C

# PRODUCT DIAGRAMS

## INDIRECT PRE-PLUMBED

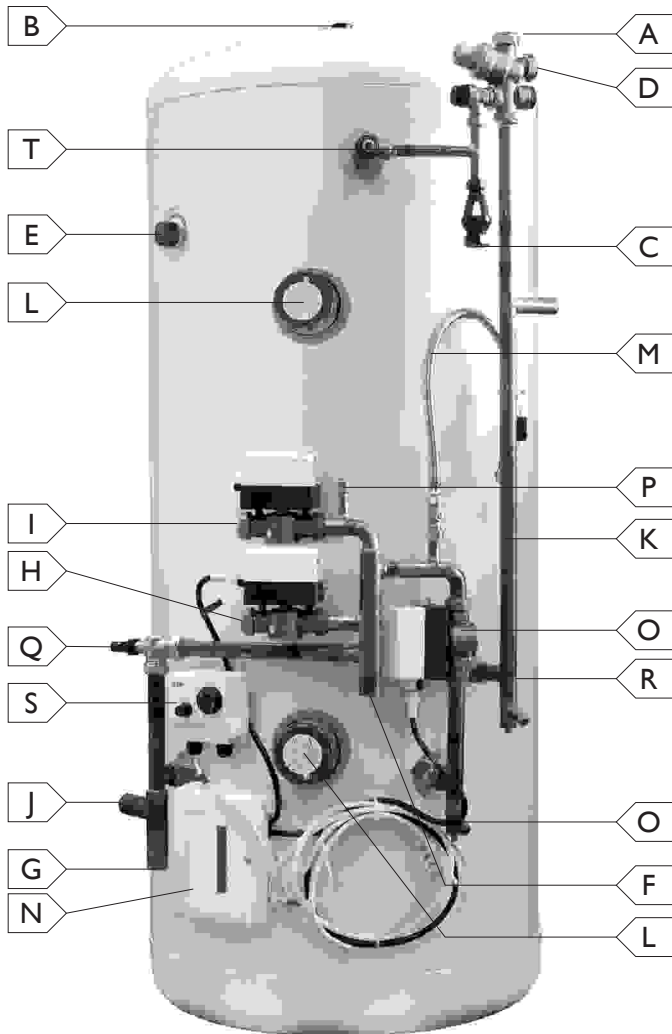

- A 22mm Inlet control set - cold feed
- B 22mm Hot water draw-off
- C 22mm Tundish drain-off
- D 22mm Balanced cold
- E Secondary return (210L, 250L & 300L)
- F 28mm Flow from boiler (28x22mm reducers are supplied)
- G 28mm Return to boiler (28x22mm reducers are supplied)
- H 22mm Central heating flow (Zone 1)
- I 22mm Central heating flow (Zone 2 - only fitted on twin zone)
- J 28mm Return from radiator circuit
- K 22mm DHW two port valve
- L Immersion heater
- M Filling loop flexible hose
- N Wiring box
- O Draincock - Heating
- P Manual bottle air eliminator
- Q Auto bypass valve
- R Cold feed draincock
- S Dual Stat
- T 1/2" Temperature relief valve

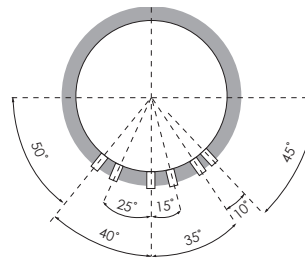

Model Type	Capacity (L)	Height (mm)	Dia (mm)	A (mm)	B (mm)	C (mm)	D (mm)	E (mm)	F (mm)	G (mm)	H (mm)	I (mm)	J (mm)
Single Zone	150	1120	550	1070	1120	782	1025	n/a	462	212	550	n/a	287
Single Zone	180	1308	550	1325	1308	1037	1280	n/a	462	212	550	n/a	287
Single Zone	210	1496	550	1445	1496	1157	1400	1150	597	246	685	n/a	321
Single Zone	250	1746	550	1695	1746	1407	1650	1400	597	246	685	n/a	321
Single Zone	300	2055	550	2008	2055	1720	1963	1602	703	246	790	n/a	321
Twin Zone	150	1120	550	1070	1120	782	1025	n/a	462	212	550	670	287
Twin Zone	180	1308	550	1325	1308	1037	1280	n/a	462	212	550	670	287
Twin Zone	210	1496	550	1445	1496	1157	1400	1150	597	246	685	805	321
Twin Zone	250	1746	550	1695	1746	1407	1650	1400	597	246	685	805	321
Twin Zone	300	2055	550	2008	2055	1720	1963	1602	703	247	790	910	321

### Slimline Pre-Plumb

Single Zone	150	1465	478	1395	1465	1117	1353	n/a	711	259	803	n/a	334
-------------	-----	------	-----	------	------	------	------	-----	-----	-----	-----	-----	-----

**Note:** Please refer to the specification insert sheet for performance details on individual cylinders.

# PRODUCT DIAGRAMS (CONTINUED)

## DIRECT

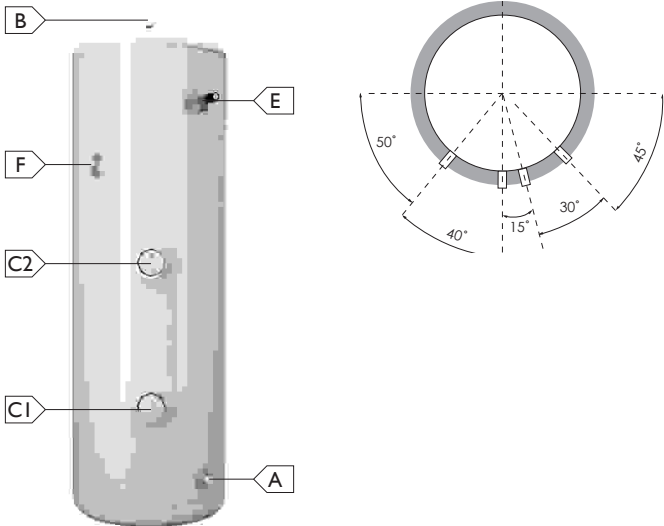

### CONNECTIONS:

- A 22mm Cold feed with dip pipe to the bottom of cylinder
- B 22m Hot water outlet
- C1 Immersion heater
- C2 Secondary immersion heater
- D1 22mm Boiler coil connections
- D2 22mm Solar coil connections
- E ½" Temperature relief valve (factory-fitted to cylinder)
- F 22mm Secondary return – for cylinders with a capacity of 210 litres and above only
- G1 Dry stat pocket
- G2 Dry stat pocket

Capacity (L)	Height (mm)	Dia (mm)	A (mm)	B (mm)	C1 (mm)	C2 (mm)	D1 (mm)	D2 (mm)	E (mm)	F (mm)	G1 (mm)	G2 (mm)
120	933	550	160	933	195	510	n/a	n/a	705	n/a	n/a	n/a
150	1120	550	160	1120	195	610	n/a	n/a	895	n/a	n/a	n/a
180	1308	550	160	1308	195	710	n/a	n/a	1080	n/a	n/a	n/a
210	1496	550	160	1496	195	810	n/a	n/a	1270	1150	n/a	n/a
250	1746	550	160	1746	195	950	n/a	n/a	1520	1400	n/a	n/a
300	2055	550	160	2055	195	1830	n/a	n/a	1687	1600	n/a	n/a

## SLIMLINE DIRECT

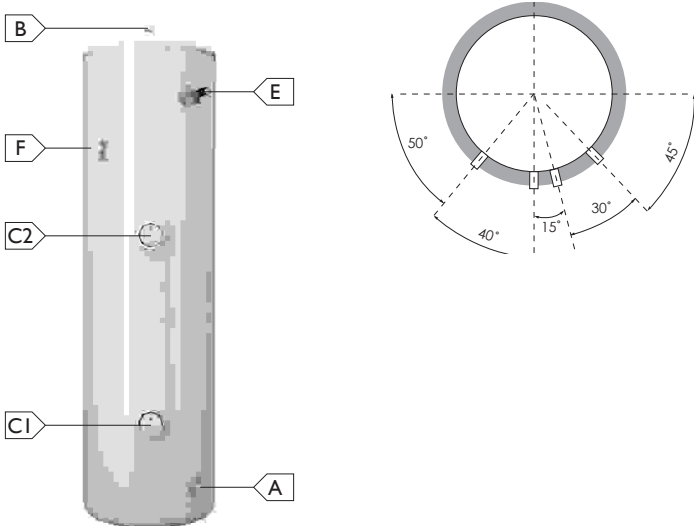

### CONNECTIONS:

- A 22mm Cold feed with dip pipe to the bottom of cylinder
- B 22m Hot water outlet
- C1 Primary immersion heater
- C2 Secondary immersion heater
- D1 22mm Boiler coil connections
- D2 22mm Solar coil connections
- E ½" Temperature relief valve (factory-fitted to cylinder)
- F 22mm Secondary return – for cylinders with a capacity of 210 litres only
- G1 Dry stat pocket
- G2 Dry stat pocket

Capacity (L)	Height (mm)	Dia (mm)	A (mm)	B (mm)	C1 (mm)	C2 (mm)	D1 (mm)	D2 (mm)	E (mm)	F (mm)	G1 (mm)	G2 (mm)
90	1091	478	175	1091	210	610	n/a	n/a	858	n/a	n/a	n/a
120	1279	478	175	1279	210	710	n/a	n/a	1046	n/a	n/a	n/a
150	1467	478	175	1467	210	810	n/a	n/a	1234	n/a	n/a	n/a
180	1717	478	175	1717	210	910	n/a	n/a	1484	n/a	n/a	n/a
210	2030	478	175	2030	210	1110	n/a	n/a	1797	1500	n/a	n/a

# PRODUCT DIAGRAMS (CONTINUED)

## INDIRECT

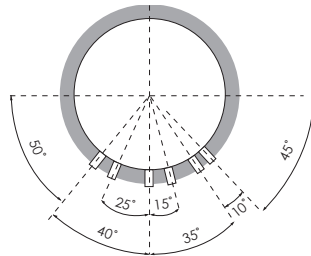
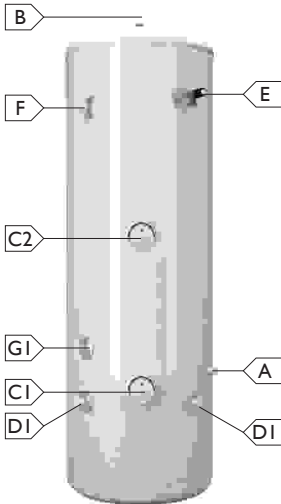

### CONNECTIONS:

- A 22mm Cold feed with dip pipe to the bottom of cylinder
- B 22m Hot water outlet
- C1 Immersion heater
- C2 Secondary immersion heater
- D1 22mm Boiler coil connections
- D2 22mm Solar coil connections
- E 1/2" Temperature relief valve (factory-fitted to cylinder)
- F 22mm Secondary return – for cylinders with a capacity of 210 litres and above only
- G1 Dry stat pocket
- G2 Dry stat pocket

Capacity (L)	Height (mm)	Dia (mm)	A (mm)	B (mm)	C1 (mm)	C2 (mm)	D1 (mm)	D2 (mm)	E (mm)	F (mm)	G1 (mm)	G2 (mm)
120	933	550	390	933	330	n/a	290	n/a	705	n/a	385	n/a
150	1120	550	465	1120	370	n/a	330	n/a	895	n/a	425	n/a
180	1308	550	465	1308	370	n/a	330	n/a	1080	n/a	425	n/a
210	1496	550	465	1496	405	n/a	365	n/a	1270	1150	465	n/a
250	1746	550	465	1746	405	950	365	n/a	1520	1400	560	n/a
300	2055	550	465	2055	405	1100	365	n/a	1830	1600	660	n/a

## SLIMLINE INDIRECT

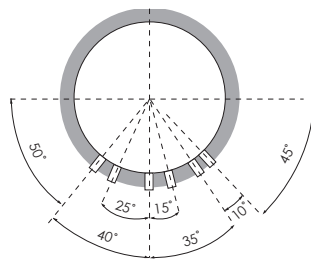
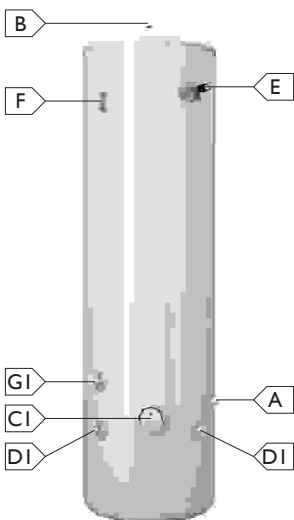

### CONNECTIONS:

- A 22mm Cold feed with dip pipe to the bottom of cylinder
- B 22m Hot water outlet
- C1 Immersion heater
- C2 Secondary immersion heater 250 & 300 litre cylinders only
- D1 22mm Boiler coil connections
- D2 22mm Solar coil connections
- E 1/2" Temperature relief valve connection (valve factory-fitted to cylinder)
- F 22mm Secondary return – for cylinders with a capacity of 210 litres only
- G1 Dry stat pocket
- G2 Dry stat pocket

Capacity (L)	Height (mm)	Dia (mm)	A (mm)	B (mm)	C1 (mm)	C2 (mm)	D1 (mm)	D2 (mm)	E (mm)	F (mm)	G1 (mm)	G2 (mm)
90	1091	478	440	1091	380	n/a	340	n/a	858	n/a	395	n/a
120	1279	478	440	1279	380	n/a	340	n/a	1046	n/a	395	n/a
150	1467	478	520	1467	420	n/a	380	n/a	1234	n/a	520	n/a
180	1717	478	520	1717	420	n/a	380	n/a	1484	n/a	610	n/a
210	2030	478	520	2030	420	n/a	380	n/a	1797	1500	710	n/a



# PRODUCT DIAGRAMS (CONTINUED)

## SOLAR INDIRECT

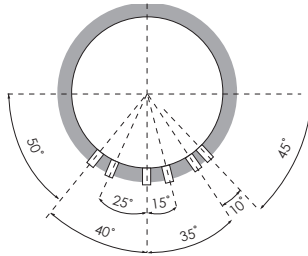
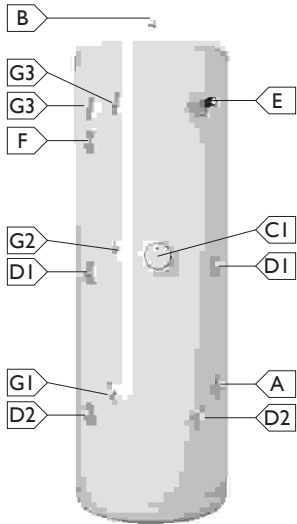

### CONNECTIONS:

- A 22mm Cold feed with dip pipe to the bottom of cylinder
- B 22mm Hot water outlet
- C1 Immersion heater
- C2 Secondary immersion heater
- D1 22mm Boiler coil connections
- D2 22mm Solar coil connections
- E ½" Temperature relief valve (factory-fitted to cylinder)
- F 22mm Secondary return – for cylinders with a capacity of 210 litres and above only
- G1 Dry stat pocket
- G2 Dry stat pocket
- G3 Dry stat pocket

Capacity (L)	Height (mm)	Dia (mm)	A (mm)	B (mm)	C1 (mm)	D1 (mm)	D2 (mm)	E (mm)	F (mm)	G1 (mm)	G2 (mm)	G3 (mm)
180	1308	550	390	1308	725	674	290	1080	n/a	345	729	1080
210	1496	550	465	1496	830	779	365	1270	1150	420	834	1270
250	1746	550	465	1746	1000	950	365	1520	1400	420	1005	1520
300	2055	550	465	2055	1030	980	365	1830	1600	420	1035	1830

# WIRING DIAGRAMS (CONTINUED)

## SOLAR HIGH LIMIT CONTROL

These schematic wiring diagrams depict an IMIT high limit control stat and the connections are numbered accordingly. Where an alternative is supplied connect as per manufacturer's instructions.

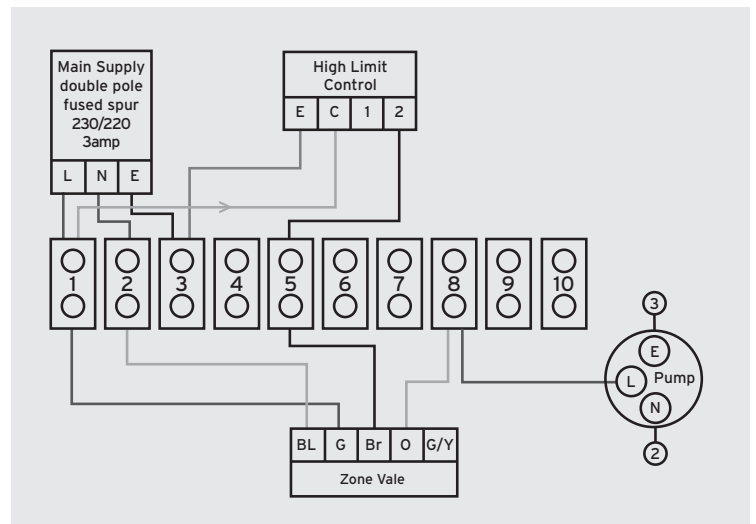
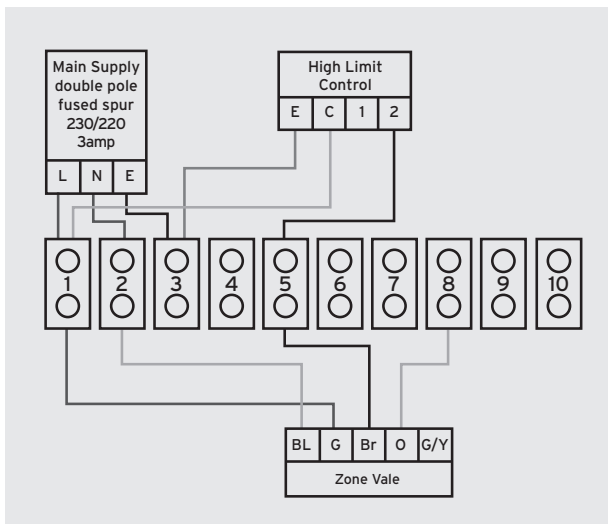

# WIRING DIAGRAMS (CONTINUED)

## INDIRECT AND PRE-PLUMBED CYLINDERS

The diagrams shown relate to the components listed. Other components and other manufacturers' components may vary in their wiring requirements, particularly thermostats. Always refer to manufacturers' instructions which may override the detail in order to function correctly.

### Heating & Hot Water Wiring: S Plan (Non Standard Volt Free Switching)

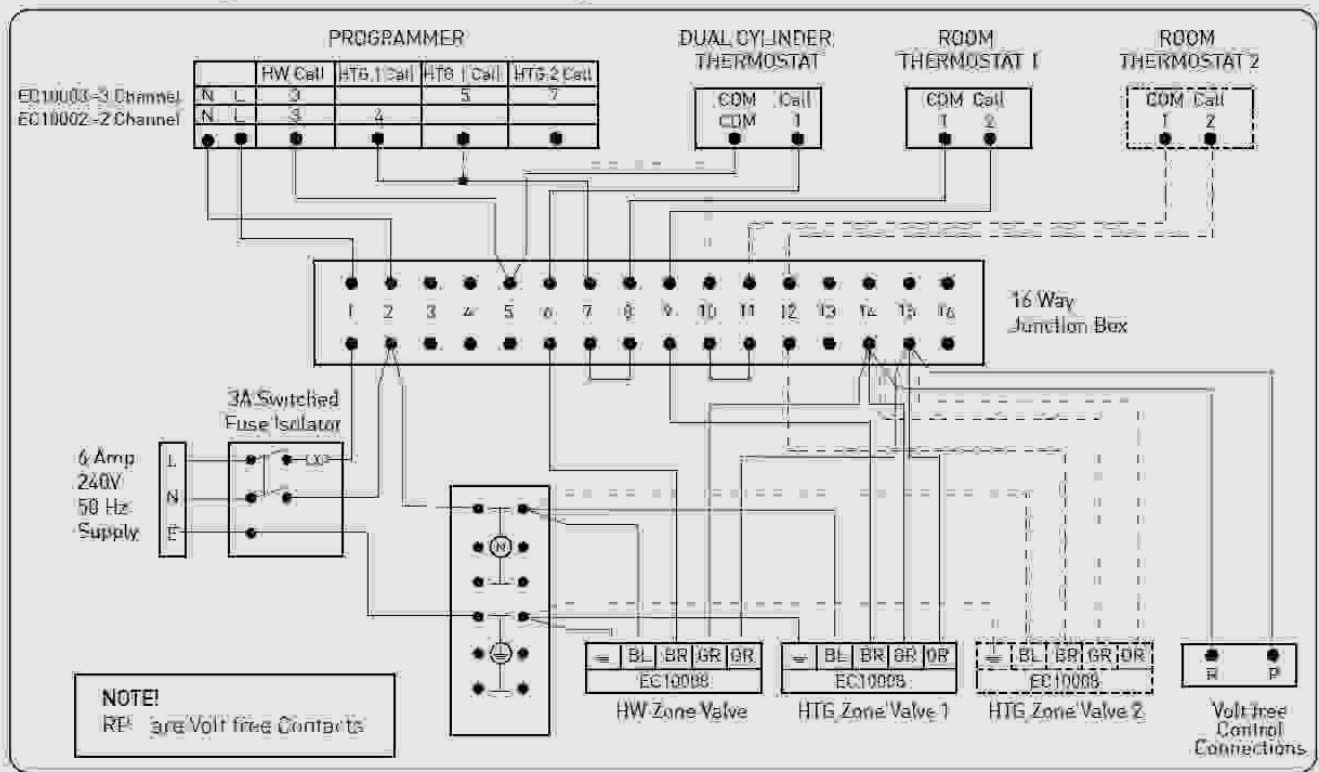

Product: WC3-1  
Description: 16 Way junction box

230V-10A 50Hz Class II -15T55  
BS6220 FIXED WIRING MAX 1.5mm



IP20  
Optional 2nd heating zone





# COMMISSIONING

## STERILISATION

Only switch on power to the immersion heaters once sterilisation liquid has been purged and the cylinder filled with water.

## FLUSHING & FILLING THE CYLINDER

Check that the pressure in the expansion vessel is 3 bar (45PSI), i.e. the same as the setting of the pressure reducing valve. The valve is of the car tyre (Schrader) type. Check all the connections for tightness including any factory made connections such as the immersion heater and the temperature and pressure relief valve. Before filling, open the hot tap furthest away from the unvented cylinder to let air out.

Open the cold main isolation valve and allow the unit to fill. When water flows from the tap allow it to run for a short while to flush through any dirt, swarf or flux residue. Close the tap and open every other hot tap in turn to purge all remaining air.

## DIRECT UNITS

Allow the unit to start to heat, the immersion heater is supplied preset at 55°C. Turning fully to '+' set to approx 65°C. Allow unit to heat up, adjust the thermostat so that the heater switches off at 60°C. Record information on the Commissioning Checklist (Page 19).

## INDIRECT UNITS

Ensure the heating circuit has been fully flushed, carrying out commissioning in line with the boiler manufacturer's commissioning instructions for the heating and the primary circuit. Primary pipework must be filled, vented and tested in accordance with the boiler manufacturer's instructions. To ensuring all pipework is fully vented, bleed valves may need opening, especially on any raised pipes; inadequate flushing or venting could cause damage to the circulation pump.

Ensure the lever on the two port valve is set to the filling position and fill the primary circuit; ensuring the appropriate inhibitors are added in the right concentrations. When full, move the lever back. Switch the programmer to Domestic Hot Water (DHW) and allow the unit to start to heat. Adjust the dial of the dual thermostat to between 55°C and 65°C as required. Allow unit to heat up, adjust the thermostat so that the heater switches off at 60°C. Record information on the Commissioning Checklist (Page 16).

## STORAGE TEMPERATURE

The recommended storage temperature for both direct and indirect cylinders is 60-65°C. In hard water areas consideration should be given to reducing this to 50-55°C. In many healthcare applications the guidance on Legionella control and safe water delivery temperatures will require storing the water at 60-65°C, distributing at 50-55°C and using thermostatic mixing valves to control the final temperature. For details consult the NHS Estates Guidance on safe hot water temperatures.

## SAFETY CHECKS

During heat-up double check all pipework for leaks, ensuring all connections including the immersion heaters and any pre-plumbed connections are water tight. There should have been no sign of water coming from either the expansion relief valve or the temperature/pressure relief valve. Now hold both of these safety valves fully open, allowing as much water as possible to flow through the tundish. Check that your discharge pipework is free from debris and is carrying the water away to waste efficiently. It is normal that some water will splash out of the tundish. This should be minimised by ensuring the tundish, D1 and D2 pipes are vertical to allow clean flow. Release the valves and check that they reseal properly. On completion of commissioning, fill in the Commissioning Checklist & leave with the homeowner.

## DECOMMISSIONING & DISPOSAL

Damage to the environment and risks to personal health are avoided by the proper decommissioning and disposal of this product.

To decommission your unvented hot water cylinder, isolate the electricity supply to the immersion heater and boiler, before draining the cylinder and safely disconnecting all fixtures and fittings.

The cylinder is made from many recyclable materials; therefore we strongly encourage recycling of this product at your Local Authority recycling centre at the end of its working life. For more information on proper disposal, please contact your local council or waste disposal office.



# SERVICING

## GENERAL

Servicing should only be carried out by competent installers and only spare parts approved by the manufacturer may be used. Never bypass any of the safety devices and never operate the unit without all of the safety devices being in place and fully operational.

## DRAINING

Isolate from the electrical supply to prevent the immersion heaters burning out. Turn off the boiler. Isolate the unit from the cold mains. Attach a hose to the draining tap ensuring that it reaches to a level below the unit (this will ensure an efficient syphon is set up and the maximum amount of water is drained from the unit). First open the hot tap closest to the unit and then open the draining tap.

**Warning: water drained off may be very hot!**

**Important:** After draining the cylinder do not close the hot tap until the cylinder has fully cooled, failure to follow this instruction may result in damage to the cylinder and will invalidate the guarantee.

## ANNUAL MAINTENANCE

The unvented cylinder requires an annual service in order to ensure safe working and optimum performance and to maintain the guarantee. It is essential that the following checks are performed by a competent installer on an annual basis. Commonly this is done at the same time as the annual boiler service.

1) Twist the cap of the expansion relief valve on the inlet control set and allow water to flow for 5 seconds. Release and make sure it reseats correctly. Repeat with the pressure / temperature relief valve. In both cases check that the discharge pipework is carrying the water away adequately. If not, check for blockages etc. and clear.

**Warning: the water discharged may be very hot!**

2) Check that any immersion heaters fitted are working correctly and that they are controlling the water at a temperature between 55°C and 65°C.

3) Check the pressure in the expansion vessel is charged to 3 bar. Turn off the water supply to the unit and open a hot tap first. The air valve on expansion vessel is a Schrader (car tyre) type. Air, nitrogen or CO<sub>2</sub> may be used to charge the expansion vessel.

4) Unscrew the head on the inlet control set and clean the mesh filter within (some water may escape).

5) The Service Record on page 20-25 of this manual must be updated at each service.

**Your guarantee may be void without proof of annual servicing.**

**Table 6:** Fault finding

Fault	Possible Cause	Solution
Water escaping from the case	Compression fitting on hot draw-off not sealing	Check/remake joint with sealing paste
	Leaking cylinder	Isolate supply and contact us
Cold water at hot taps	Direct - immersion heater not switched on or cut-out has triggered	Check / reset
	Indirect - boiler not working	Check boiler - consult boiler manufacturer's instructions
	Indirect - motorised valve fault	Check plumbing / wiring to motorised valve
	Indirect - cut-out in dual stat has operated	Reset and investigate cause
Water discharges from expansion relief valve	If continual - pressure reducing valve (part of inlet control set) may not be operating correctly	Check outlet pressure from inlet control set is 3 bar
	If continual - expansion relief valve seat may be damaged	Remove cartridge - check seat and renew if necessary
	If intermittent - expansion vessel charge may have reduced / bladder perished	Check pressure in expansion vessel. Recharge to 3 bar if necessary. If bladder perished replace vessel
	Unit is being back pressurised	With cylinder cold check pressure in cylinder. If this is the same as the incoming mains pressure then you are getting backfeed. Install a balanced cold supply (see page 7)
Water discharges from temperature & pressure relief valve	Unit has overheated - thermal controls have failed	Switch off power to boiler and immersion heaters. Leave water supply on. Wait until discharge stops. Isolate water supply and replace if faulty
Milky / cloudy water	Oxygenated water	Water from any pressurised system will release oxygen bubbles when flowing. The bubbles will settle out
No hot water flow	Cold mains off	Check and open stopcock
	Strainer blocked in pressure reducing valve	Isolate water supply and clean
	Inlet control set may be fitted incorrectly	Check and refit as required
Noise during hot water draw-off - typically worse in the morning	Loose pipework	Install extra clips
	Water hammer	Fit a shock arrestor
Hot or warm water from cold tap	If tap runs cold after a minute or so the pipe is picking up heat from heating pipework	Insulate / re-route



# INFORMATION FOR HOMEOWNERS

## SPARE PARTS

See insert sheet for a list of part numbers.

## USER INSTRUCTIONS

Your stainless system is automatic in normal use and requires only annual servicing, normally this is timed to coincide with the annual boiler service. You should employ a competent installer to perform the annual service and the installer **MUST** complete the service history to maintain your 25-year guarantee on the inner vessel. see the guarantee terms and conditions on pages 26-28 for further details.

**If water is flowing from the safety valves through the tundish, this indicates a fault in your heating system and action is needed.**

If this water is hot, turn the boiler and/or immersion heaters off. Do not turn off the water until the discharge runs cool. The discharge may also stop.

**Call out a competent installer to diagnose the fault.**

Tell them you have a fault on your hot water system and that the system includes an unvented hot water cylinder.

## AFTER DRAINING

**Important:** After draining the cylinder, the hot tap must be left fully open until the cylinder has fully cooled, failure to follow this instruction may result in damage to the cylinder & will invalidate the guarantee.

## SPECIFICATION - CYLINDER DETAILS & PERFORMANCE

Please refer to the insert sheet that came with this installation manual.

**Important:** Please ensure that the installer has fully completed the Commissioning Checklist on page 19 of the installation instructions supplied with the product and that you have signed it to say that you have received a full and clear explanation of its operation.

The installer is legally required to complete this Commissioning Checklist as a means of complying with the appropriate Building Regulations.

All installations must be notified to Local Area Building Control either directly or through a Competent Persons Scheme. A Building Regulations Compliance Certificate will then be issued to the customer who should, on receipt, write the Notification Number on the Commissioning Checklist. This product should be serviced regularly to optimise its safety, efficiency and performance. The service engineer should complete the relevant Service Record Commissioning after each service. The Commissioning Checklist and Service Record will be required in the event of any guarantee claim.



# COMMISSIONING RECORD

Commissioning Date..... Engineer's Name.....

Customer Name..... Company Name.....

Customer Phone Number ..... Company Address .....

Cylinder Model Number ..... Telephone Number.....

Cylinder Serial Number ..... Registered Operator ID Number.....

Building Regulation Notification Number (if applicable)

.....

## PRIMARY INDIRECT SYSTEM INFORMATION

Primary circuit      SEALED      OPEN VENTED

Primary circuit flow temperature .....

Primary circuit expansion vessel size required .....

Primary circuit expansion vessel pre-charge .....

Primary flow temperature .....

Where is the Pressure Reducing Valve fitted?

.....

What is the PRV setting?.....

Has the Expansion Relief Valve been tested? .....

Has the T & P valve been tested? .....

Does the discharge pipework meet building regulations?

.....

## POTABLE WATER INFORMATION

What is the standing pressure at the cylinder? .....

What is the dynamic pressure at the cylinder? .....

What is the pre-charge in the potable vessel? .....

Does the discharge pipework carry discharge away in a safe manor? .....

Have all safety features been checked? .....

DOES THE INSTALLATION COMPLY WITH THE APPROPRIATE BUILDING REGULATIONS?	YES	NO
HAS THE SYSTEM BEEN COMMISSIONED IN LINE WITH INSTRUCTIONS?	YES	NO
HAS THE PRIMARY CIRCUIT BEEN DOSED WITH INHIBITOR?	N/A	YES      NO
HAVE THE CORRECT CONTROLS BEEN INSTALLED?	YES	NO
HAS THE SYSTEM BEEN FULLY EXPLAINED TO THE CUSTOMER?	YES	NO

COMMISSIONING ENGINEER SIGNATURE.....

CUSTOMER SIGNATURE .....DATE .....



# SERVICE HISTORY

SERVICE 1 Date.....

Engineer's Name.....

Company Name.....

Telephone Number.....

Pressure in Potable Expansion Vessel.....

Safety valves functioning    YES            NO

Actions .....

Discharge pipe clear            YES            NO

Actions.....

Temperature of hot water.....

Immersion heater connected    YES            NO    N/A

Actions .....

Signature.....

SERVICE 2 Date.....

Engineer's Name.....

Company Name.....

Telephone Number.....

Pressure in Potable Expansion Vessel.....

Safety valves functioning    YES            NO

Actions .....

Discharge pipe clear            YES            NO

Actions.....

Temperature of hot water.....

Immersion heater connected    YES            NO    N/A

Actions .....

Signature.....

SERVICE 3 Date.....

Engineer's Name.....

Company Name.....

Telephone Number.....

Pressure in Potable Expansion Vessel.....

Safety valves functioning    YES            NO

Actions .....

Discharge pipe clear            YES            NO

Actions.....

Temperature of hot water.....

Immersion heater connected    YES            NO    N/A

Actions .....

Signature.....

SERVICE 4 Date.....

Engineer's Name.....

Company Name.....

Telephone Number.....

Pressure in Potable Expansion Vessel.....

Safety valves functioning    YES            NO

Actions .....

Discharge pipe clear            YES            NO

Actions.....

Temperature of hot water.....

Immersion heater connected    YES            NO    N/A

Actions .....

Signature.....



# SERVICE HISTORY

SERVICE 5 Date.....

Engineer's Name.....

Company Name.....

Telephone Number.....

Pressure in Potable Expansion Vessel.....

Safety valves functioning    YES            NO

Actions .....

Discharge pipe clear            YES            NO

Actions.....

Temperature of hot water.....

Immersion heater connected    YES            NO    N/A

Actions .....

Signature.....

SERVICE 6 Date.....

Engineer's Name.....

Company Name.....

Telephone Number.....

Pressure in Potable Expansion Vessel.....

Safety valves functioning    YES            NO

Actions .....

Discharge pipe clear            YES            NO

Actions.....

Temperature of hot water.....

Immersion heater connected    YES            NO    N/A

Actions .....

Signature.....

SERVICE 7 Date.....

Engineer's Name.....

Company Name.....

Telephone Number.....

Pressure in Potable Expansion Vessel.....

Safety valves functioning    YES            NO

Actions .....

Discharge pipe clear            YES            NO

Actions.....

Temperature of hot water.....

Immersion heater connected    YES            NO    N/A

Actions .....

Signature.....

SERVICE 8 Date.....

Engineer's Name.....

Company Name.....

Telephone Number.....

Pressure in Potable Expansion Vessel.....

Safety valves functioning    YES            NO

Actions .....

Discharge pipe clear            YES            NO

Actions.....

Temperature of hot water.....

Immersion heater connected    YES            NO    N/A

Actions .....

Signature.....



# SERVICE HISTORY

SERVICE 9 Date.....

Engineer's Name.....

Company Name.....

Telephone Number.....

Pressure in Potable Expansion Vessel.....

Safety valves functioning    YES            NO

Actions .....

Discharge pipe clear            YES            NO

Actions.....

Temperature of hot water.....

Immersion heater connected    YES            NO    N/A

Actions .....

Signature.....

SERVICE 10 Date.....

Engineer's Name.....

Company Name.....

Telephone Number.....

Pressure in Potable Expansion Vessel.....

Safety valves functioning    YES            NO

Actions .....

Discharge pipe clear            YES            NO

Actions.....

Temperature of hot water.....

Immersion heater connected    YES            NO    N/A

Actions .....

Signature.....

SERVICE 11 Date.....

Engineer's Name.....

Company Name.....

Telephone Number.....

Pressure in Potable Expansion Vessel.....

Safety valves functioning    YES            NO

Actions .....

Discharge pipe clear            YES            NO

Actions.....

Temperature of hot water.....

Immersion heater connected    YES            NO    N/A

Actions .....

Signature.....

SERVICE 12 Date.....

Engineer's Name.....

Company Name.....

Telephone Number.....

Pressure in Potable Expansion Vessel.....

Safety valves functioning    YES            NO

Actions .....

Discharge pipe clear            YES            NO

Actions.....

Temperature of hot water.....

Immersion heater connected    YES            NO    N/A

Actions .....

Signature.....



# SERVICE HISTORY

SERVICE 13 Date.....

Engineer's Name.....

Company Name.....

Telephone Number.....

Pressure in Potable Expansion Vessel.....

Safety valves functioning    YES            NO

Actions .....

Discharge pipe clear            YES            NO

Actions.....

Temperature of hot water.....

Immersion heater connected    YES            NO    N/A

Actions .....

Signature.....

SERVICE 14 Date.....

Engineer's Name.....

Company Name.....

Telephone Number.....

Pressure in Potable Expansion Vessel.....

Safety valves functioning    YES            NO

Actions .....

Discharge pipe clear            YES            NO

Actions.....

Temperature of hot water.....

Immersion heater connected    YES            NO    N/A

Actions .....

Signature.....

SERVICE 15 Date.....

Engineer's Name.....

Company Name.....

Telephone Number.....

Pressure in Potable Expansion Vessel.....

Safety valves functioning    YES            NO

Actions .....

Discharge pipe clear            YES            NO

Actions.....

Temperature of hot water.....

Immersion heater connected    YES            NO    N/A

Actions .....

Signature.....

SERVICE 16 Date.....

Engineer's Name.....

Company Name.....

Telephone Number.....

Pressure in Potable Expansion Vessel.....

Safety valves functioning    YES            NO

Actions .....

Discharge pipe clear            YES            NO

Actions.....

Temperature of hot water.....

Immersion heater connected    YES            NO    N/A

Actions .....

Signature.....



# SERVICE HISTORY

SERVICE 17 Date.....

Engineer's Name.....

Company Name.....

Telephone Number.....

Pressure in Potable Expansion Vessel.....

Safety valves functioning    YES            NO

Actions .....

Discharge pipe clear            YES            NO

Actions.....

Temperature of hot water.....

Immersion heater connected    YES            NO    N/A

Actions .....

Signature.....

SERVICE 18 Date.....

Engineer's Name.....

Company Name.....

Telephone Number.....

Pressure in Potable Expansion Vessel.....

Safety valves functioning    YES            NO

Actions .....

Discharge pipe clear            YES            NO

Actions.....

Temperature of hot water.....

Immersion heater connected    YES            NO    N/A

Actions .....

Signature.....

SERVICE 19 Date.....

Engineer's Name.....

Company Name.....

Telephone Number.....

Pressure in Potable Expansion Vessel.....

Safety valves functioning    YES            NO

Actions .....

Discharge pipe clear            YES            NO

Actions.....

Temperature of hot water.....

Immersion heater connected    YES            NO    N/A

Actions .....

Signature.....

SERVICE 20 Date.....

Engineer's Name.....

Company Name.....

Telephone Number.....

Pressure in Potable Expansion Vessel.....

Safety valves functioning    YES            NO

Actions .....

Discharge pipe clear            YES            NO

Actions.....

Temperature of hot water.....

Immersion heater connected    YES            NO    N/A

Actions .....

Signature.....





# SERVICE HISTORY

SERVICE 21 Date.....

Engineer's Name.....

Company Name.....

Telephone Number.....

Pressure in Potable Expansion Vessel.....

Safety valves functioning    YES            NO

Actions .....

Discharge pipe clear            YES            NO

Actions.....

Temperature of hot water.....

Immersion heater connected    YES            NO    N/A

Actions .....

Signature.....

SERVICE 22 Date.....

Engineer's Name.....

Company Name.....

Telephone Number.....

Pressure in Potable Expansion Vessel.....

Safety valves functioning    YES            NO

Actions .....

Discharge pipe clear            YES            NO

Actions.....

Temperature of hot water.....

Immersion heater connected    YES            NO    N/A

Actions .....

Signature.....

SERVICE 23 Date.....

Engineer's Name.....

Company Name.....

Telephone Number.....

Pressure in Potable Expansion Vessel.....

Safety valves functioning    YES            NO

Actions .....

Discharge pipe clear            YES            NO

Actions.....

Temperature of hot water.....

Immersion heater connected    YES            NO    N/A

Actions .....

Signature.....

SERVICE 24 Date.....

Engineer's Name.....

Company Name.....

Telephone Number.....

Pressure in Potable Expansion Vessel.....

Safety valves functioning    YES            NO

Actions .....

Discharge pipe clear            YES            NO

Actions.....

Temperature of hot water.....

Immersion heater connected    YES            NO    N/A

Actions .....

Signature.....



# GUARANTEE - TERMS & CONDITIONS

guarantee applies only to the product named EHC Neptune Unvented Hot Water Cylinder. Hereafter the term 'product' refers to EHC Neptune Hot Water Cylinder.

Electric Heating Company guarantees to the homeowner that for a period of 2 years on the stainless steel inner vessel and 1 year on parts from the date of commissioning or legal completion if new build, that the products and associated components installed will conform to EHC specification; and be free from defects in materials and workmanship, subject to the conditions set out below.

**Please note:** This guarantee excludes all pipework and connections and excludes any ancillary equipment as may be connected to the product. (Ex: descaling equipment, water softeners)

The guarantee is extended to a total of 25 years for the stainless steel inner vessel and 2 years on parts in domestic properties.

This guarantee means that Electric Heating Company will take responsibility for the cost of guarantee repair of a product by an approved Electric Heating Company Service Engineer, so that the product shall conform to Electric Heating Company specification.

Electric Heating Company reserves the right, at its discretion to replace a product or major component where it considers it to be beyond economical repair.

In the event of a breakdown during the guarantee period please call our Customer Service Department on: **01698 820533**

Guarantee repair is free of charge to you for any parts and labour, providing all the guarantee conditions have been met.

## GUARANTEE TERMS & CONDITIONS

Please read the following conditions before registering your product and before seeking any guarantee service support **IMPORTANT:** Electric Heating Company guarantee is subject to the homeowner registering with the Electric Heating Company Customer Service Department within 30 days of commissioning / occupation if new build to confirm:

- Product Make / Model
- Details of installation

Please complete the registration card provided and return to:  
Customer Service Department,  
Electric Heating Company,  
Unit 40 Block 5 Third Road Blantyre  
Glasgow  
G72 0UP

or register the product on-line at:  
[www.electric-heatingcompany.co.uk/warranty-registration/](http://www.electric-heatingcompany.co.uk/warranty-registration/)

If you do not register the Product then Electric Heating Company Guarantee is limited to twelve months from the date of commissioning.

The product must be maintained by a competent person\* within 12 months after commissioning, and thereafter at 12 monthly intervals. Electric Heating Company reserves the right to seek evidence of this maintenance to our reasonable satisfaction before approving any guarantee servicing / repairs. This may include evidence of completed Service Record and service agreement / invoice. Annual Services are available from the Customer Service/Technical Support team.

\*A competent person is a business that has been adjudged by an accredited body\*\* to be sufficiently competent to self-certify that its work complies with Document (G) Part 3 of the Building Regulations of England and Wales.

\* May Include SEI registered installers and/or FAS trained plumbers who have completed the renewables technology module

\*\* An example of which is BPEC Any exchanged component will become the legal property of Electric Heating Company.

This guarantee is valid provided that:

- The product has been installed by a competent installer and as per the instructions contained in the installation manual and all relevant Codes of Practice and Regulations in force at the time of installation.

- Any disinfection has been carried out in accordance with BS 6700.

- The product has not been modified in any way.

- The system is fed from domestic mains water supply and is in compliance with water regulations 1999, the water supply(Scotland) byelaws 2014, water supply regulations(Northern Ireland) 2009 or the water services act(Ireland) 2007

- The system is fed from domestic mains water supply compliant with Water Regulations 2000 i.e. the water must not be supplied from a well or bore hole.

- The product has only been used for the storage of wholesome water (max. 200mg/l chloride – for hard water areas, EHC recommend the use of an electrolytic scale reducer)

- Any 3rd party labour charges associated with replacing the unit or any of its components have been authorised in advance by the Customer Service/ Technical Support team.

- It has only been used for the storage of potable water.

- The product has not been subjected to frost, nor has it been tampered with or been subjected to misuse or neglect.

- No factory fitted parts have been removed for unauthorised repair or replacement.

- The Commissioning Checklist and Service Record included with this product Installation Manual have been completed.

- Regular maintenance has been carried out by a competent person in accordance with the requirements set out in the maintenance section of the installation manual.

- The owner or installer has registered the product on-line at [www.electric-heatingcompany.co.uk/warranty-registration](http://www.electric-heatingcompany.co.uk/warranty-registration) within 30 days of purchase or by sending completed Guarantee slip (page 28). Failure to do so may result in a reduced warranty period.

- Evidence of purchase and date of supply must be submitted upon making a claim.

- Any replacement parts used should be authorised Electric Heating Company spare parts.

- If a defect arises and a valid claim is received within the warranty period, at its option and to the extent permitted by law the Electric Heating Company shall either:

(1) Repair the defect at no charge, using new or refurbished replacement parts

or

(2) Exchange the product with a product that is new or which has been manufactured using new or serviceable used parts

or



# GUARANTEE - TERMS & CONDITIONS

(3) Refund the purchase price or a reasonable proportion of the purchase price.

The Electric Heating Company reserves the right to inspect the product at your home before proceeding with any guarantee repair or replacement.

Any valid guarantee claim or guarantee service does not extend the original guarantee period. Information on extend warranties is available upon request.

The guarantee only applies to the property at which the product was originally installed and applied only to properties in the United Kingdom & Ireland. The guarantee is fully transferable from a change of legal ownership of the property.

**EXCLUSIONS** – The guarantee does not cover:

Electric Heating Company will not be liable for any fault or costs arising from incorrect installation, incorrect application, lack of regular maintenance or neglect, accidental damage, malicious damage, misuse, any alteration, tampering or repair carried by a non competent person.

- The product if the factory fitted temperature and pressure relief valve has been tampered with or removed.
- Neither the Distributor nor Manufacturer shall be responsible for any consequential damage howsoever caused.
- The effects of scale build up or the effects of corrosion.
- Additional costs that result from inadequate access provision such as removal of walls, ceilings, doors, other equipment or damage to decorative finishes, such as tiles, skirting board, door frames etc. Sufficient access is defined as enough space to reach all parts for servicing and maintenance up to and including the full removal and exchange of the cylinder.

• Any consequential losses caused by the failure or malfunction of the product.

• Faults and any associated costs arising from lack of power or water.

• Failure incurred by water contamination, air pollution and natural disasters.

• This guarantee is not valid for installations outside the United Kingdom and Ireland.

• Any consequential loss, loss of profits, revenues or receipts howsoever arising from any non-conformity or defect affecting the product or from any delay in repair or replacement of the product.

• Any loss or damage caused by delay in conduct of services or supply of parts required to rectify the non-conformity or defect (provided Electric Heating Company will use all reasonable efforts to ensure services are performed on a timely basis).

• For repair or replacement of any product consumables or decorative finishes, such as filters and casings. This guarantee does not affect any legal rights you may have as a consumer under applicable national legislation governing your purchase of this product. For installations outside of the United Kingdom and Ireland, please contact Customer Service/Technical Support. The Electric Heating Company shall make final determination as to the validity of any guarantee claim, and shall be entitled to charge you all reasonable costs incurred in investigating the claim where there is no fault found, or the guarantee claim is rejected in accordance with these conditions.



AFFIX  
YOUR  
STAMP  
HERE

Customer Service Department  
The Electric Heating Company Ltd  
Unit 40 Block 5 Third Road  
Blantyre Industrial Estate  
Blantyre Glasgow  
G72 0UP



# GUARANTEE REGISTRATION CARD

To be completed by the home owner. Please use this card to register within 30 days of commissioning / occupation if new build to benefit from the Electric Heating Company 25 year guarantee.

By completing this form, you consent to Electric Heating Company holding and using those details for all purposes directly related to the administration and conduct of guarantee services. Apart from the necessary usage, your personal data will not be disclosed to third parties by Electric Heating Company.



Homeowner Name  
(Mandatory)

Installation Address  
(Mandatory)

Post code

Email Address:

Phone  
Number:

Make of Product

Model/Size

Serial Number  
(Mandatory)

Installers Contact Details  
(can be found in Commissioning Checklist)

Date of Installation  
(can be found in Commissioning Checklist)

Signature of Homeowner

Date

Or Signature of Developer  
(if new build)

Date