

KONA

Basso NOx

Faible NOx

Niski poziom NOx

Low NOx



CE

GENERAL WARNINGS



- Please read the warnings in this instruction booklet carefully, as they provide important information on installation, use and maintenance.
 - This instruction booklet is an integral and essential part of the product and the user must store it carefully so it can be consulted whenever necessary.
 - If the unit is sold or given to another owner or if its location is changed, the manual must go with it so the new owner or installer can consult it.
 - Installation and maintenance must be performed by an authorized technician, in compliance with applicable regulations and the manufacturer's instructions.
 - Incorrect installation or inadequate maintenance can cause personal injury or material damage. The manufacturer does not accept any liability for damage caused by errors in installation and use or by failure to follow the instructions provided.
 - Before doing any cleaning or maintenance work, disconnect the unit from the power supply using the system switch or another cut-off device.
 - In the event of a fault or malfunction, disconnect the unit and only have it repaired by an authorized technician.
- Only use professionally qualified personnel. Repairs and component replacements may only be carried out by authorized technicians using original replacement parts. Failure to comply with the above may compromise the safety of the unit.
- Regular maintenance performed by qualified personnel is essential to ensure proper operation of the unit.
 - This unit must only be used for its intended purpose. Any other use is considered inappropriate and therefore dangerous.
 - Unpack the unit and check that it is in perfect condition. The packing materials are a potential source of danger, and must be kept out of reach of children.
 - The unit can be used by children aged 8 years and over and by persons with impaired physical, sensory or mental abilities or lacking experience or the necessary knowledge, provided they are supervised and instructed in its safe use and they understand the hazards associated with its use. Children must not play with the unit. The unit's cleaning and maintenance to be done by the user can be performed by children aged 8 and over if they are supervised

at all times.

- If in any doubt, do not use the unit and consult your supplier.
- Dispose of the unit and its accessories in compliance with applicable regulations.
- The images included in this manual are a simplified representation of the

product. This representation can have slight and insignificant differences vis-a-vis the product supplied.

- **UNIT FOR DOMESTIC USE, NOT SUITABLE FOR INDUSTRIAL USE**

	<p><i>This symbol means “Caution,” and is displayed next to safety warnings. Observe these warnings strictly to prevent dangerous situations or injury/damage to people, animals and materials.</i></p>
	<p>This symbol refers to information that does not include hazards for people or materials.</p>



The CE marking certifies that products meet the fundamental requirements of the applicable European directives.

The declaration of conformity can be requested from the manufacturer.

INDEX





1 INSTRUCTIONS FOR USE.....	60
1.1 Presentation	60
1.2 Display symbols	60
1.3 Control panel keys.....	60
1.4 Control Panel.....	60
1.5 OPERATION.....	60
1.5.1 ON and OFF.....	61
1.5.2 NORMAL Operation	61
1.5.2.1 Temperature Setting.....	61
1.5.2.2 Domestic Hot Water	61
1.5.3 ECO mode.....	61
1.5.3.1 Enabling ECO mode	61
1.5.3.2 Temperature Setting in ECO mode	61
1.5.3.3 Disabling ECO mode.....	61
1.5.4 Solar Energy Function.....	61
2 INSTALLATION INSTRUCTIONS.....	62
2.1 General instructions	62
2.2 Installation location	62
2.3 Installing the water heater	62
2.4 Hydraulic connections	63
2.5 Gas connection	63
2.6 Electrical connections.....	64
2.7 Air and flue gas ducts	64
2.7.1 Connection with coaxial pipes.....	64
2.7.2 Connection with separate pipes	65
3 SERVICE AND MAINTENANCE.....	66
3.1 ADJUSTMENTS	66
3.1.1 Gas conversion	66
3.1.2 Gas valve calibration.....	67
3.1.3 Electronic board replacement.....	68
3.2 COMMISSIONING	68
3.2.1 Before turning the water heater on.....	68
3.2.2 Checks during operation	68
3.3 MAINTENANCE	68
3.3.1 Regular check	68
3.3.2 Opening the casing	69
3.4 ERRORS	69
3.4.1 Error list.....	69
3.4.2 Error History	69
3.5 PARAMETERS.....	69
3.5.1 Parameter list	70
4 CHARACTERISTICS AND TECHNICAL DATA	71
4.1 Dimensions and connections	71
4.2 Overview and main components	72
4.3 Technical Data Table	73
4.4 Electrical diagram.....	74

1 INSTRUCTIONS FOR USE

1.1 Presentation

The new **KONA** is a COMPLETELY SEALED high-performance water heater with low environmental pollution emissions for providing domestic hot water, supplied with **Natural Gas, LPG or propane-air** and fitted with a latest technology burner, with high modulation, which reduces the emission of pollutant gases and provides stable and precise combustion. It also includes a fan that works in combination with the burner, and from an **intuitive and touch-sensitive microprocessor control system**. This water heater **can also work together with solar panels**.

1.2 Display symbols

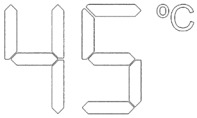
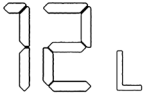
SYMBOL	DESCRIPTION
	FLAME: This symbol lights when the burner is on.
	TAP: This symbol lights when water flows through the unit.
	FAN: This symbol lights when the fan's motor is on.
	ECO: This symbol lights when the ECO function is enabled.
	TOP DIGITS: 1. Water temperature (shows the real temperature of the water outlet by default) 2. Temperature setpoint (touching the + / - keys) 3. Error codes 4. Value of each parameter
	BOTTOM DIGITS: 1. Water flow 2. Reference Parameters

1.3 Control panel keys

SYMBOL	DESCRIPTION
ECO	ECO Function: This key is used to enable/disable the ECO mode.
	STANDBY: This key is used to put the unit into STANDBY mode and/or OPERATIONAL mode.
+	These keys change the temperature setpoint, both NORMAL and ECO, and the internal parameters.
-	

1.4 Control Panel

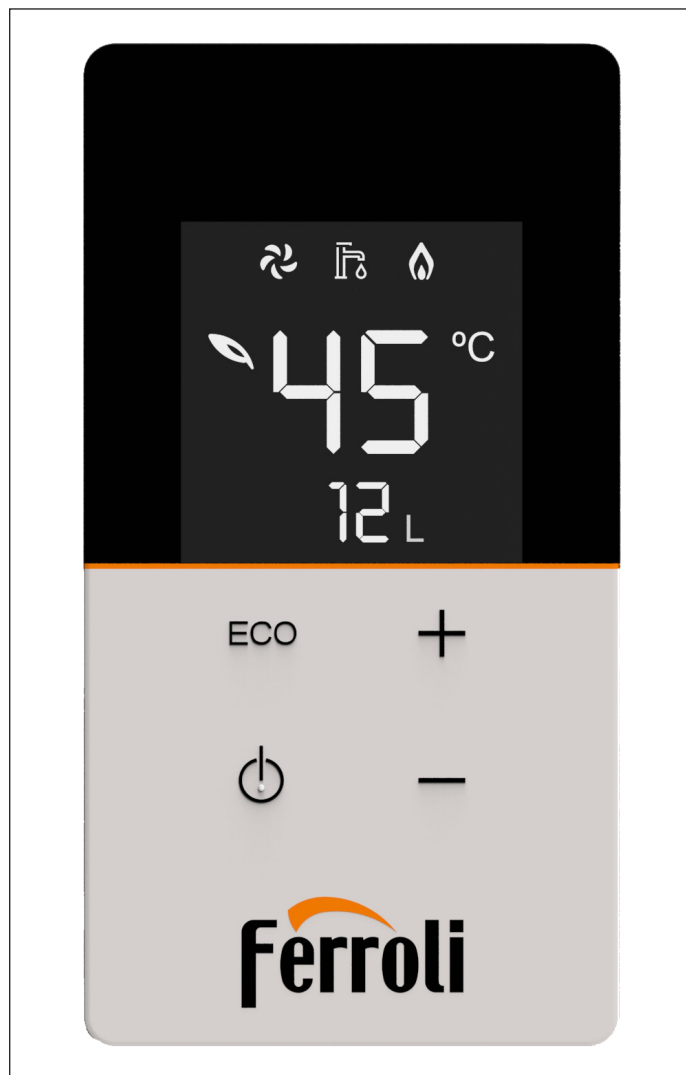

1.5 OPERATION

This Gas Water Heater OPERATES as follows:

- STANDBY (in Stand-by Mode)
- OPERATIONAL:
 - NORMAL Mode
 - NORMAL Mode with support from Thermal Solar Energy
 - ECO Mode
 - ECO Mode with support from Thermal Solar Energy

1.5.1 ON and OFF

From the STANDBY mode, by touching the **Standby** key the unit becomes OPERATIONAL, turning the display on. From OPERATIONAL state, by touching the **Standby** key the unit goes to STANDBY mode, turning the display off. In both cases an acoustic signal confirms each action.

In STANDBY mode the burner does not start when a tap is opened.

1.5.2 NORMAL Operation

The water heater's NORMAL operation instantly provides domestic hot water at the required temperature and set by the user. When the water heater's normal operation is activated, the real water outlet temperature is shown, and the  symbol is turned off.



1.5.2.1 Temperature Setting

The outlet water temperature can be set with the “+” and “-” keys.

The NORMAL temperature setting is between 35 °C and 50 °C (*the maximum value, initially 50 °C, can be changed via the nS parameter, see Section 3.5*). The normal temperature setting is 50 °C by default.

1.5.2.2 Domestic Hot Water

When the tap is opened and a water flow is detected by the flowmeter, the unit begins to operate, and the  symbol lights on the display.

The fan symbol  and the flame symbol  come on according to the state they are in.

When the tap opens the bottom digits display shows the current water flow rate ().

The water heater will heat water continually for a maximum of 60 minutes (*value which can be changed via the nE parameter, see Section 3.5*), after which it will stop for safety reasons.

1.5.3 ECO mode

This mode is generally used to reduce energy consumption. When this function is enabled the  symbol is shown on the top digits display.

In ECO mode the outlet capacity is limited to 80 % of the maximum value, and a separate temperature setting is used.

1.5.3.1 Enabling ECO mode

If this mode is disabled, you must touch the **ECO** key. The  symbol will then light immediately on the display.

During this mode, when opening the tap the burner begins the ignition sequence and when the electrode detects the flame, the unit keeps the burner on and modulating the fan and the gas.

1.5.3.2 Temperature Setting in ECO mode

In this mode the water temperature setpoint can be different to that in the NORMAL mode, but it will never be higher than it. This ECO temperature setting, just like the NORMAL one, can be changed with the “+” and “-” keys.

The ECO temperature setting is therefore between 35 °C and the NORMAL temperature setting. The normal ECO temperature setting is 42 °C by default.

1.5.3.3 Disabling ECO mode

To deactivate this mode, touch the **ECO** key on the control panel. The  symbol goes off.

1.5.4 Solar Energy Function

To operate the water heater together with solar panels and use the solar energy they supply, there are some parameters that define the water heater's behavior. The water heater will only activate when the inlet water temperature, produced by solar energy, is lower than the set temperature.

In the description of parameters (**see Section 3.5**), “**FC**” must be on “ON”, as there are 3 other key parameters:

S1: Hysteresis to turn the burner on (default 10 °C)

S2: Hysteresis to turn the burner off (default 10 °C)

t1: Delay time to turn the burner on (default 10 s)

- When the inlet water T is < (setting T - S1), the burner starts the t1 timing, or the time after which the burner ignites.
- When the inlet water T is > (setting T + S2), the burner turns off.

Once the burner has ignited, for the first 30 seconds, to prevent it from continuously going on and off when starting, the control unit automatically increases the turned off T to the setting T + 30 °C.

To change these parameters, S1, S2 and t1, see Section 3.5. Parameter list.

2 INSTALLATION INSTRUCTIONS

2.1 General instructions



The installation must only be performed by an authorized installation technician, as must the electrical, gas and fumes/air exhaust/intake connections respectively, complying with all instructions provided in this manual, the EN 26 standard, as well as the local regulations for installing and venting combustion products.

2.2 Installation location

- The combustion circuit is sealed off from the installation environment, so the unit can be installed in any room. However, the room must be sufficiently ventilated to prevent dangerous situations if there is a gas leak.
- **REGULATION (EU) 2016/426** stipulates the safety standards for all installations that work with gas, including those with a sealed chamber.
- The unit can operate in a location partially protected in accordance with the **EN 26** standard.

In any case, the unit must be installed in a location free of dust, flammable objects or materials, or corrosive gases.

The unit can be installed on the wall:

- Attach to the wall according to the dimensions shown in **Section 4.1**. The wall installation must be firm and stable.
- Do not install the unit over a heat source.

👉 If the unit is installed inside a closet, for example, or if it connects laterally to other elements, a space must be left to remove the unit's casing and to perform regular maintenance work.

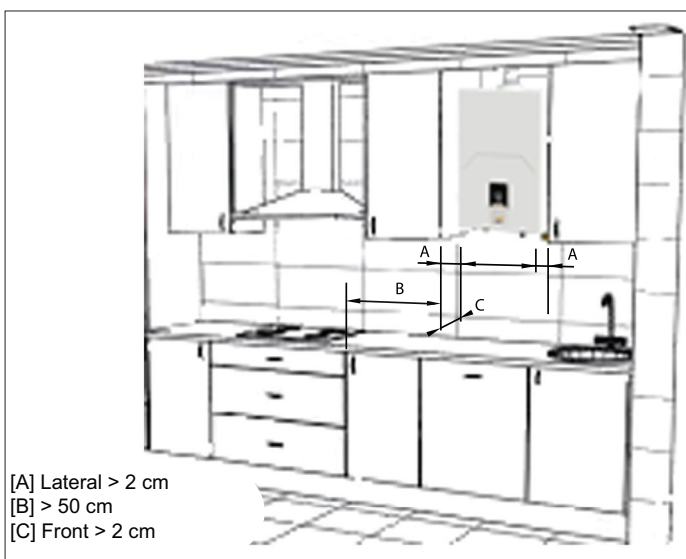

[A] Lateral > 2 cm
[B] > 50 cm
[C] Front > 2 cm

2.3 Installing the water heater



Before installing the water heater make sure the water and gas connections are correctly secured, identified and positioned.

See the dimensions and connections in Section 4.1.

- 1 - The installation template is on the back of the packaging. Cut it out and place it on the wall at the correct height (check distances), making sure that the template is as horizontal as possible (use a level).
- 2 - Mark the position of the attachment holes.
- 3 - With a drill and \varnothing 8 mm bit, make the attachment holes and attach the expansion plugs.
- 4 - Remove the unit from the packaging, take out the bag of accessories that comes with the unit, remove the screws and/or attachment hooks and place the unit in its position.
- 5 - Make sure all the documentation is provided.
- 6 - Remove the plugs from the water and gas connections.
- 7 - On the rating plate check the destination country reference and type of gas for which the supplied unit is regulated.



KONA 12

ODK96KAA Ser. n.: 2219LE9006

B32-C12-C22-C32-C42-C52-C62-C82-C92

II2HM3B/P (IT)	II2H3B/P (IE)
II2R3R (FR)	II2H3P (GB)
II2Esi3P (FR)	II2Er3P (FR)
II2ELwLs3B/P (PL)	

3P - G31 - 37 mbar

Q_n (Hi)	=	max	-	min	
		23	-	4	kW
$P_n - P_{min}$	=	20.9	-	3.6	kW

t_{max}	=	65	°C	p_w	=	10	bar
				D	=	10	l/min

NOx 6 (< 56 mg/kWh) H₂O

0085 / 22

8 430709 516557

2219LE9006

230 V ~ 50 Hz

34 W

IPX4D

For outdoor installation in partially protected place
Temp. min.: -5 °C

MADE IN SPAIN

Fig. 1 - Rating plate

2.4 Hydraulic connections

Never support the water heater on water/gas connections. Make the connections in accordance with the dimensions and connections in Section 4.1.

The inlets (water and gas) and water outlet are identified on the bottom of the unit. All are 1/2".

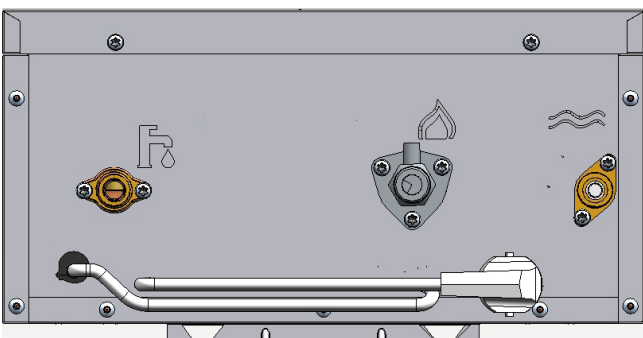

SYMBOL	DESCRIPTION
	Symbol for the mains WATER inlet
	Symbol for the mains GAS inlet
	Symbol for the HOT WATER outlet

If the water hardness is over 25 °fH (1 °fH = 10 ppm CaCO₃), the water must be treated to avoid possible deposits on the unit.

2.5 Gas connection

Before connecting, check that the unit has been prepared for operation with the fuel type and carefully clean all the gas pipes to remove residues that could impair the unit's operation. Make this connection in accordance with the dimensions and connections in Section 4.1.

- 1 . Connect the gas inlet (see Section 4.1) in accordance with the applicable regulations of the country where the water heater is installed.
- 2 . Connect with a **rigid metal pipe** (connection to mains gas supply) or a **flexible pipe** (approved, do not confuse with flexible elastomer connection) for LPG installation, continuous stainless steel from the wall, adding a shut-off valve between the installation and the unit (**AS CLOSE TO THE UNIT AS POSSIBLE**).
- 3 . After completing the connection to the gas mains, check that all gas connections are tight. For this purpose, a tightness test must be performed. To avoid damage to the unit due to excess pressure, leave the gas inlet valve closed.

Check that the supply pressure and the flow supplied in the unit are those indicated for the unit's consumption.

See and check the Technical Data Table, **Section 4.3**.

In installations with flexible pipe for LPG (approved, do not confuse with flexible elastomer connection), pay special attention to the following:

- The pipe must comply with applicable regulations.
- Avoid areas with heat emissions.
- Prevent the pipe from bending or being pinched shut.
- The connections on both sides (gas valve and other components) must comply with the regulations of the country where the water heater is installed.

2.6 Electrical connections

The unit's electrical safety must be ensured with grounding, as established by safety standards. Have qualified personnel check the effectiveness of the grounding system, as the manufacturer will not be liable for any damage caused by a lack of grounding on the installation.

The unit's power cable may not be replaced by the user. If the cable is damaged, turn off the unit and call the authorized technical support center to have it replaced.

To replace it use only **HAR H05 VV-F** cable, 3 x 0.75 mm² with a maximum outer diameter of 8 mm.

2.7 Air and flue gas ducts

This is a type C unit, with a sealed chamber and forced draft. The air inlet and flue gas outlet must be connected to systems such as those indicated below.

The unit is approved for operation with all configurations of the **Cxy** flue shown on the technical data card (some of these are shown as an example below).

It is however possible that some configurations are limited or prohibited by law, standards or local regulations.

Before installing, check and strictly comply with the requirements in question.

Also comply with the provisions for hanging on walls and/or ceilings and the minimum distances to windows, cables, ventilation openings, etc. **Section 2.2**

2.7.1 Connection with coaxial pipes

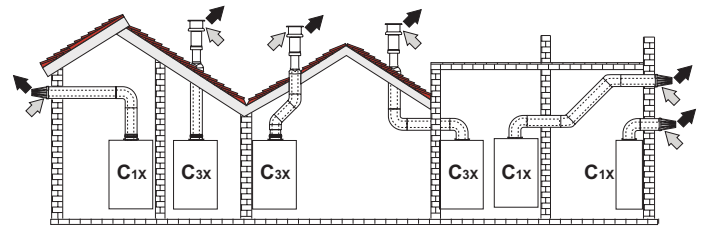

Fig. 2 - Example of a connection with coaxial pipes

- C1x** - Horizontal aspiration and evacuation on the wall.
- C3x** - Vertical aspiration and evacuation on the ceiling.

➡ = Air
➡ = Flue gases

	Coaxial 60/100	Coaxial 80/125
Maximum permitted length	4 m	10 m
Elbow reduction factor 90°	1 m	0.5 m
Curve reduction factor 45°	0.5 m	0.25 m

For coaxial connection, install one of the following initial accessories on the unit. For drilling dimensions on the wall, **see Section 4.1**. Horizontal exhaust segments must slope slightly toward the outside to prevent any condensation from returning to the unit.

- For coaxial vertical pipe connection Ø 60/100 (**010037X0**):

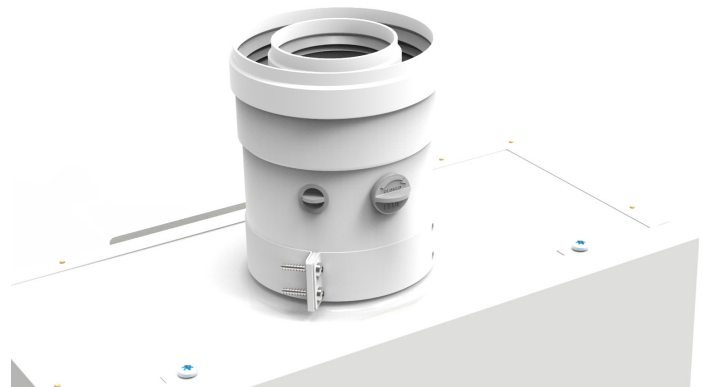

- For coaxial vertical pipe connection adjusted from Ø 60/100 to Ø 80/125 (**010038X0**):

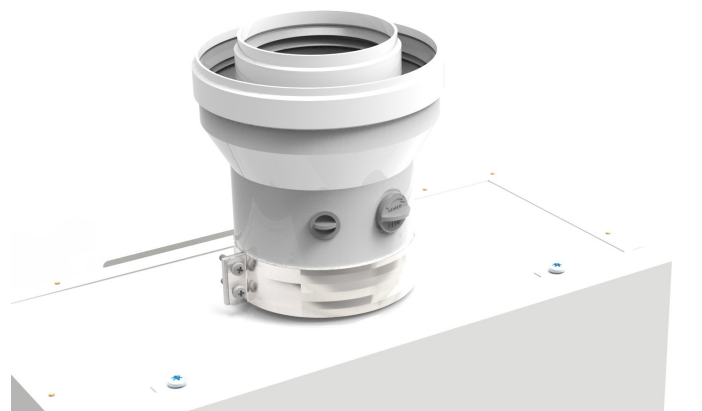

- Aspiration duct Kit / coaxial exhaust
For 90° connection + coaxial pipe, Ø 60/100 (010040X0):



- For connecting separate pipes to Ø 80/100 (010039X0):

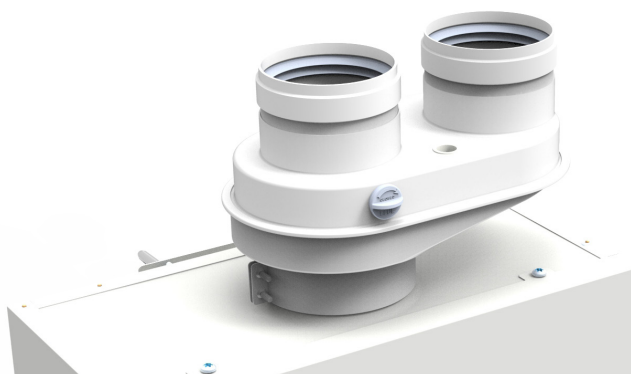

Before proceeding with the installation, check, by means of a simple calculation, that the maximum chimney length allowed is not exceeded:

2.7.2 Connection with separate pipes

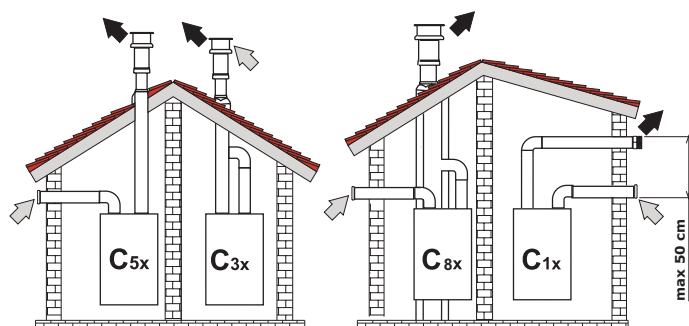

Fig. 3 - Example of a connection with separate pipes

- C1x** - Horizontal aspiration and evacuation on the wall. Intake and exhaust terminals must be concentric, or close enough to be exposed to similar wind conditions (maximum distance of 50 cm).
- C3x** - Vertical aspiration and evacuation on the ceiling. Intake/exhaust terminals suitable for C12.
- C5x** - Separate aspiration and evacuation on the wall or ceiling or, in any case, in areas under different pressure. Aspiration and evacuation may not be placed on opposite walls.
- C6x** - Aspiration and evacuation with separate certified pipes (EN 1856-2).
- B3x** - Aspiration from the installation environment and evacuation in the collector system.

- = Air
- = Flue gases

IMPORTANT – THE INSTALLATION LOCATION MUST HAVE APPROPRIATE VENTILATION.

- Design the entire system of separate flues, including the accessories and the exhaust terminals.
- Check **Table 1** and determine the losses in m_{eq} (equivalent meters) for each component, depending on its assembly position.
- Make sure that the total sum of the losses is less than or equal to the maximum length indicated on **Table 2**.

Table 1

		Loss in m_{eq}		
		Air inlet	Flue gases outlet	
			Vertical	Horizontal
Ø 80	PIPE	0.5 m M/H	0.5	1
		1 m M/H	1	2
		2 m M/H	2	4
	CURVE	45° H/H	1.2	2.2
		45° M/H	1.2	2.2
		90° H/H	2	3
		90° M/H	1.5	2.5
	HOSE	90° M/H + outlet for testing	1.5	2.5
		With outlet for testing	0.2	0.2
	T	For condensate discharge	-	3
		For condensate discharge	-	7
	TERMINAL	Wall air	2	-
		Wall fumes with wind screen	-	5
	FLUE	Separate for air/fumes 80/80	-	12
Only exhaust vent Ø 80		-	4	

Table 2

MAXIMUM PERMITTED LENGTH		
KONA 12	KONA 15	KONA 17
65 m_{eq}	55 m_{eq}	45 m_{eq}

3 SERVICE AND MAINTENANCE

All adjustments, start-up work and regular checks described below must be performed by an authorized technician and in compliance with applicable regulations. FERROLI does not accept any responsibility for personal injury or material damages resulting from work on the unit by people that are not authorized to do so.

3.1 ADJUSTMENTS

3.1.1 Gas conversion

FERROLI KONA water heater is only provided set for one of the following three gases:

- **G20** (METHANE, NATURAL GAS)
- **G31** (PROPANE, LPG)
- **G230** (propane-air)

depending on the model purchased, as indicated on the packaging and on the technical data plates.

The unit can operate with NATURAL GAS (G20, G25), with PROPANE AIR (G230) or with LPG (G30, G31). The unit can be adjusted to work with a gas that is different to that set in the factory, with the following steps according to the type of gas conversion:

- 1 - Close the gas valve
- 2 - Convert via the GAS TRANSFORMATION KIT
Except for changes between G30 and G31
- 3 - Set the FA parameter (type of water heater and gas)
- 4 - Open the gas valve
- 5 - Calibrate the gas valve
Except for changes between G30 and G31
- 6 - Place the new data label

1 - Close the gas valve

Before beginning any conversion:

- The gas valve must be closed.
- The water heater must then be connected to the new gas that it is to be converted to.

2 - Convert via the GAS TRANSFORMATION KIT



The conversion for operation with a gas that is different to that set in the factory must be performed by an authorized technician, using original parts and in compliance with the applicable regulations of the country of use.



All components damaged during the conversion work must be replaced.

For every gas conversion in the KONA water heater, **except in the LPG model to change between G30 to G31 (from PROPANE to BUTANE and vice versa, without a Kit)**, the appropriate Transformation Kit must be purchased and installed, according to the type of gas the water heater will work with, and the model in liters of the KONA that we have:

TRANSFORMATION KIT		CODE
- KONA 12	TO G20 GAS	R83000280
	TO G30 / G31 GAS (LPG)	R83000290
	TO G25 / G230 GAS	R83000300
- KONA 15 - KONA 17	TO G20 GAS	R83000250
	TO G30 / G31 GAS (LPG)	R83000260
	TO G25 / G230 GAS	R83000270

The following steps apply to install the Transformation Kit:

1. Disconnect the KONA water heater from the power supply.
2. Remove the burner's collector and mount the new one according to the instructions of the **Transformation Kit** provided.
3. Connect the KONA water heater to the power supply.

3 - Set the FA parameter (type of water heater and gas)

A simple setting must be made on the electronics; simply configure the "FA" parameter correctly. This indicates the water heater's model type, that is, the liters and type of gas setting:

- 1 Activate the parameter list by pressing the **ECO** key for 5 seconds until "PP" appears on the display. Touch the **Standby** key and the first "FA" parameter appears.
- 2 To do this you must touch the **Standby** key and change the value of the current parameter with the "+" and "-" keys, according to the water heater model and its type of gas (**see Section 3.5.1 Parameter list**).
- 3 Once configured, **confirm this initial "FA" parameter with the Standby key.**

These steps always apply for the following 2 cases:
(Cases A and B)

A. Gas conversion from G31 to G30, Propane to Butane and vice versa (from G30 to G31, Butane to Propane)

If you have purchased the KONA LPG model, which will be preset at the factory to G31 (Propane), **to convert it to G30 (Butane) the “FA” parameter must simply be set**, which in this example would be the following setting:

	Model:	12 L / 15 L / 17 L
From factory value, for G31 (Propane):		2 / 7 / 12
to the new value, for G30 (Butane):		3 / 8 / 13

according to the liters of the water heater model, as shown in the parameter table (see Section 3.5.1). To convert the other way, always with the KONA LPG model, from G30 to G31, the process would be the same up to this point, changing the FA parameter with the corresponding value.

In this case, after changing the FA parameter no more changes must be made on the electronics, so you can continue by touching the “+” key until you reach the last “qU” parameter. From this final parameter, **you must confirm and leave by touching the Standby key**.

B. Gas conversion with Transformation Kit

If the gas conversion has been performed by converting the water heater, **the FA parameter must also be set first, according to the gas that the KONA water heater will work with:**

	Model:	12 L / 15 L / 17 L
- Transformed to G20:		1 / 6 / 11
- Transformed to GLP (G31, Propane):		2 / 7 / 12
(G30, Butane):		3 / 8 / 13
- Transformed to G25:		4 / 9 / 14
- Transformed to G230:		5 / 10 / 15

and according to the liters of the water heater model, as shown in the parameter table (see Section 3.5.1).

In this case, after changing the FA parameter the gas valve must be calibrated, via consecutive parameters to FA.

4 - Open the gas valve

After confirming the new FA parameter value the water heater is already set for the new gas and the gas valve can be opened.

5 - Gas valve calibration

The gas valve must be calibrated for every gas conversion on the KONA that has been converted with the corresponding Kit (**that is, for every conversion except the LPG model, which converts from G31 to G30 and vice versa**).

For this follow **Section 3.1.2 entirely to perform this step correctly**.

6 - Placing the new gas technical data label

To show that the gas conversion has been correctly completed, place the new adhesive technical data label on the water heater’s casing, replacing the one that came from the factory with the new one:

- Additional G30 gas label which comes with your KONA LPG (for conversions from G31 to G30).

- Corresponding gas label (G20, G30, G31, G25, G230) which comes with the corresponding Transformation Kit.

3.1.2 Gas valve calibration

This must only be performed in the following cases:

- GAS VALVE REPLACEMENT
- ELECTRONIC CARD REPLACEMENT
- GAS CHANGE WITH TRANSFORMATION

The gas valve (with integrated modulating actuator) is not calibrated mechanically; the minimum and maximum capacity is adjusted electronically via 2 parameters:

Par.	Description	Range
PH	Total Maximum Pressure (entire burner)	20 - F0
P2	Minimum Pressure (burner minimum section)	20 - F0

GAS VALVE CALIBRATION

- 1 **Check that the supply pressure according to the type of gas complies with that shown on the Technical Data Table (see Section 4.3).**
- 2 **On the same Technical Data Table, check the Maximum Pressure and Minimum Pressure values of your water heater, according to the water heater model and type of gas, to take them into account in the following steps.**
- 3 Connect a gauge to check the outlet pressure of the gas valve.
- 4 Touch the **Standby** key
- 5 Activate the parameter list by touching the **ECO** key for **5 seconds** until “PP” appears on the display. Touch the **Standby** key and the first “FA” parameter appears.
- 6 Touch the “+” key once and the first parameter of the valve to be calibrated appears, “PH”, relative to Maximum Pressure.
- 7 Selecting “PH”, you must touch the **Standby** key to enter its calibration, showing its internal value of the Maximum Pressure parameter.
- 8 To set the “PH” parameter, touch the “+” or “-” key on the panel until the gauge shows the Maximum nominal Pressure minus 1 mbar. Wait 10 seconds for the pressure to stabilize. If the gauge shows a different value to the maximum nominal pressure, increase the “PH” parameter in steps with the “+” key. After each change, wait 10 seconds for the pressure to stabilize. If the gauge shows the same value as the Maximum nominal Pressure, confirm it with the **Standby** key.

- 9 To set the next parameter to be calibrated, from “PH” you must touch the “+” key 8 times, until you reach the “P2” parameter, relative to the Minimum Pressure.
- 10 Selecting “P2”, you must touch the **Standby** key to enter its calibration, showing its internal value of the Minimum Pressure parameter.
- 11 To adjust the “P2” parameter, touch the “+” or “-” key on the panel until the gauge shows the Minimum nominal Pressure plus 0.5 mbar. Wait 10 seconds for the pressure to stabilize. If the gauge shows a different value to the minimum nominal pressure, reduce the “P2” parameter in steps with the “-” key. After each change, wait 10 seconds for the pressure to stabilize. If the gauge shows the same value as the Minimum nominal Pressure, confirm it with the **Standby** key.
- 12 To complete the calibration process you must then touch the “+” key until you reach the final “qU” parameter. **From this final parameter**, you must confirm and exit by touching the **Standby** key.
- 13 Disconnect the gauge.
- 14 Touch the Standby button again to turn on the water heater.

3.1.3 Electronic board replacement

- Remove the power supply.
- Replace the electronic board and restore the power supply.
- Turn the water heater OFF using the **Standby** key.
- Press the **ECO** key (about 5 s) until the **PP** symbol appears.
- Press the **Standby** key. The **FA** symbol will appear.
- Press the **Standby** key.
- Press the + or - keys to set the correct value (see table 3.5.1).
- Press the Standby key to confirm the value. The **FA** symbol appears.
- To exit the parameters menu, press the + key until the **qU** symbol appears.
- Press the **Standby** key. The water heater switches off.
- Press the **Standby** key again to turn on the device.

3.2 COMMISSIONING



Commissioning of the water heater must be performed by a trained, specialized technician.

Checks that must be performed during the first ignition, after maintenance work which requires the unit to be disconnected and after every intervention on the unit's safety devices or components.

3.2.1 Before turning the water heater on

- Check the tightness of the gas installation carefully for leaks on the connections using a soap and water solution.
- Let the water flow into the hydraulic circuit and check that there are no water leaks in the system or in the appliance.
- Check that there are no water leaks in the installation or the unit.
- Check that the connection to the electrical system and the grounding are correct.
- Check that the gas pressure is correct.
- Check that there are no flammable liquids or materials near the water heater.
- Do not place the water heater on the floor with the connections facing down, so the connections are not damaged.

3.2.2 Checks during operation

- Turn the unit on.
- Make sure the fuel and water systems are tight.
- Check the efficiency of the air and flue gas ducts while the water heater is operating.
- Check that the gas valve modulates correctly.
- Check that the water heater ignites easily by doing a few on and off tests.
- Check that the fuel consumption indicated on the meter matches that shown in the Technical Data Table, **Section 4.3**.

3.3 MAINTENANCE

3.3.1 Regular check

In order for the unit to operate correctly, an authorized technician must perform an annual inspection, checking that:

- The control and safety devices (gas valve, flowmeter, etc.) work correctly.
- The exhaust vent is perfectly efficient.
- The air and flue gas ducts and terminal are free of obstacles and leaks.
- The burner and the exchanger have no dirt or deposits. Do not use chemicals or steel brushes to clean them.
- The electrode is free of deposits and properly positioned.
- The gas and water systems are perfectly tight.
- The gas delivery and operating pressure values are as indicated on the tables.

 ***A soft, damp cloth may be used to clean the casing and exterior parts of the water heater, using soapy water if necessary. Do not use abrasive detergents or solvents.***

3.3.2 Opening the casing

To open the casing:

- 1 Unscrew the screws
- 2 Remove the front panel
- 3 Disconnect the Display Panel's wiring



Before doing any work inside the water heater, disconnect the power supply and close the gas valve.

3.4 ERRORS

The water heater is fitted with an advanced self-testing system. If a problem arises with the unit, the fault symbol will flash on the display and the respective code will be displayed, with an acoustic signal sounding at the same time. If a fault occurs, all gas valves close immediately. The fan continues moving for 30 seconds, until it stops. **With the E2 error, the fan will continue moving until the flame signal disappears, at which point it will stop 30 seconds later.**

To reset the unit's operation after an error, it is enough to just close the hot water tap, or to touch the **Standby** key, to put the water heater into STANDBY. **With the E2 error, the user must unplug the water heater and plug it in again to reset it.** If the error persists after these reset steps, the fault must be resolved.

3.4.1 Error list

Code	Error	Possible cause
E0	Fault in the outlet temperature probe	Water outlet NTC temperature probe sensor open or shorted
E1	No ignition or no flame	The system does not detect a flame after two attempts to ignite, or there is no flame during normal operation
E2	Presence of a flame anomaly or parasitic flame	Before starting the system detects the flame, or after the system stops for 5 s and then detects the flame
E3	Overheating cut-off thermostat	Overheating safety cut-off thermostat circuit open
E4	Fault with the inlet temperature probe	Water inlet NTC temperature probe sensor open or shorted
E5	Fan fault	Speed continuously under 600r/min for 2 s, or the system cannot detect the speed signal
E6	ACS overheating	Water outlet NTC probe sensor temperature above 85 °C for 5 s
E7	Valve fault	Valves that activate shorted transistors or valves in open circuit
E8	Blocked pipe	Fan speed above the wind screen pressure warning speed preset by the software, or above the HC or LC values shown in the parameter menu (see HC and LC parameters)
En	ACS time up	Maximum continuous heating time, according to nE (60 min by default, see nE parameter)
EC / Ec	Display panel connection	Fault on the main electronic card's communication wiring with the display panel

3.4.2 Error History

From the **STANDBY** state, keep the “ – ” **key pressed for 5 seconds** to access the Error History Interface, initially showing “HI”. Touching the **Standby** key you begin to see the last 10 Errors that occurred in the water heater. At this point the lower display shows the last error code that occurred, and the upper display shows “01”, beginning to list the errors that occurred. Scrolling through them, 01~10, the last ten water heater error codes appear. Touch the **Standby** key to exit the history view.

Touch the “ – ” key to change from “HI” to recovery of Errors “rE”; from this option, keep the ECO key pressed for 5 seconds to delete the history (the 10 Errors) and exit the interface at the same time. From either of the two modes, “HI” or “rE”, keep the “ – ” key pressed for 5 seconds to exit the error history interface.

3.5 PARAMETERS

There is a parameter list (which the user cannot change), to make internal settings in the water heater. Access to the Parameter menu is made from the **STANDBY** state keeping **the ECO key pressed for 5 seconds**, until “PP” appears on the display. Touch the **Standby** key and the first “FA” parameter appears on the display.

All parameters can be changed from the control panel. The “+” key or the “-” key are used to scroll through the parameter list, to reach the parameter you want to set. Once you have selected the parameter you want, touch the **Standby** key and you will see its current value. To change the parameter’s value touch the “+” or “-” keys until you reach the value you want.

To confirm the value touch the **Standby** key, returning to show the parameter list, to go forward or back to a different parameter to set it. **After setting the parameters you want, you must reach the last parameter of the “qU” list (touching the “+” key until you get to it), and confirm the completed configuration by touching the Standby key from this parameter, to exit saving all changes.**

3.5.1 Parameter list

Par.	Description	Range	Default value														
			KONA 12					KONA 15					KONA 17				
FA	Unit regulation: - Water heater type (12 L, 15 L, 17 L) - Gas type (G20, G31, G30, G25, G230)	1 - 15	G20	G31	G30	G25	G230	G20	G31	G30	G25	G230	G20	G31	G30	G25	G230
			1	2	3	4	5	6	7	8	9	10	11	12	13	14	15
PH	TOTAL MAXIMUM PRESSURE – Entire burner	20 - F0	b7	dE	C1	C6	b7	9A	bC	A6	A9	9d	A9	d3	b2	bC	AC
FH	Maximum fan speed – Entire burner	20 - F0	A4	A3	A3	A4	A3	bb	Ad	b4	A5	bb	Cd	d1	Cd	Cd	Cd
PL	Minimum pressure – Entire burner	20 - F0	6c	6F	6F	6c	6F	71	7d	75	7B	74	71	7d	75	7B	74
FL	Minimum fan speed – Entire burner	20 - F0	4E	4d	4d	4E	4d	67	64	62	67	67	67	64	62	67	67
dH	Start pressure	20 - F0	83	8F	8F	83	8F	80	A0	A0	84	83	80	A0	A0	84	83
dF	Fan speed during Start-up	20 - F0	5F	4d	4d	5F	4d	6A	60	75	6A	6A	6A	60	75	6A	6A
P1	Maximum pressure – Burner minimum section	20 - F0	C1	dA	dA	C1	dA	A8	F0	d6	b7	Ab	A8	F0	d6	b7	Ab
F1	Maximum fan speed – Burner minimum section	20 - F0	9b	98	98	9b	98	dA	C3	C8	dA	dA	dA	C3	C8	dA	dA
P2	MINIMUM PRESSURE – Burner minimum section	20 - F0	6d	75	71	6E	6E	6E	83	7b	72	71	6E	83	7b	72	71
F2	Minimum fan speed – Burner minimum section	20 - F0	53	4A	4A	53	4A	6d	77	76	6d	6d	6d	77	76	6d	6d
P3	Maximum pressure – Burner section 2	20 - F0						97	bF	b1	A0	9A	97	bF	b1	A0	9A
F3	Maximum fan speed – Burner section 2	20 - F0						bE	A3	Ad	bE	bE	bE	A3	Ad	bE	bE
P4	Minimum pressure – Burner section 2	20 - F0						66	70	6d	68	69	66	70	6d	68	69
F4	Minimum fan speed – Burner section 2	20 - F0						45	4E	4E	45	45	45	4E	4E	45	45
P5	Maximum pressure – Burner section 3	20 - F0						A5	d3	b6	b3	A8	A5	d3	b6	b3	A8
F5	Maximum fan speed – Burner section 3	20 - F0						C9	C8	C8	C9	C9	C9	C8	C8	C9	C9
P6	Minimum pressure – Burner section 3	20 - F0						71	80	77	75	74	71	80	77	75	74
F6	Minimum fan speed – Burner section 3	20 - F0						64	69	69	64	64	64	69	69	64	64
HC	Fan safety cut-off speed at Maximum Pressure	20 - 89	67 Hz					82 Hz					82 Hz				
LC	Fan safety cut-off speed at Minimum Pressure	20 - 89	34 Hz					56 Hz					56 Hz				
nE	Burner continuous operation timing	OFF / 20 - 60	60 min														
nP	Enable or Disable Operational State memory	OFF - ON	ON														
FC	Enable or Disable Solar Energy Function	OFF - ON	OFF														
S1	Solar function – ON hysteresis	1 - 20	10 °C														
S2	Solar function – OFF hysteresis	1 - 20	10 °C														
t1	Solar function – Initial time to turn burner on	0 - 20	10 s														
nS	Maximum hot water temperature Setting	50 - 65	50 °C														
nL	Minimum water flow options for Start/Stop -- 0: 4/3.5 L/min -- 1: 3.5/3 L/min -- 2: 3/2.5 L/min -- 3: 2.5/2 L/min -- 4: 2/1.5 L/min	0 - 4	2 (3/2.5 L/min)														
qU	EXIT and SAVE changes	-	-														

Notes:

The parameters that show different values, vary the operating mode (never the range) in relation to the initial FA parameter (*water heater model according to the type of Gas and Liters*). The parameters marked in gray (from P3 to F6) only appear in the real parameter list if the FA value is between 6 and 15 (*that is, for all models other than the 12 Liters*).

4 CHARACTERISTICS AND TECHNICAL DATA

4.1 Dimensions and connections

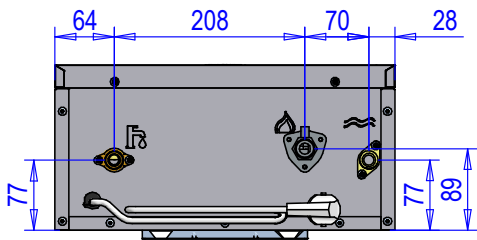

15L-17L

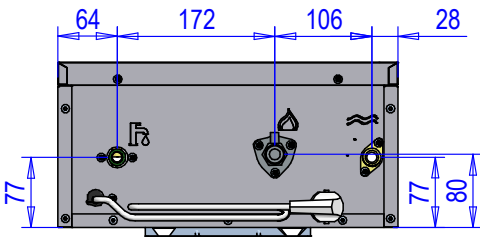

12L

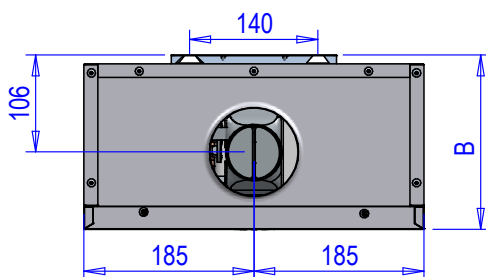
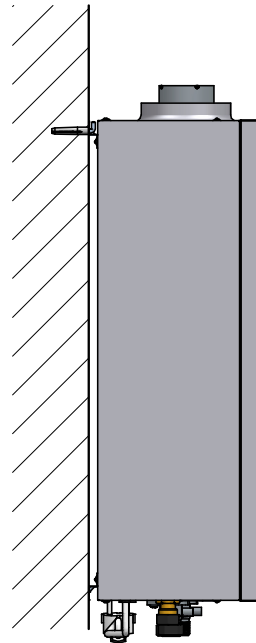
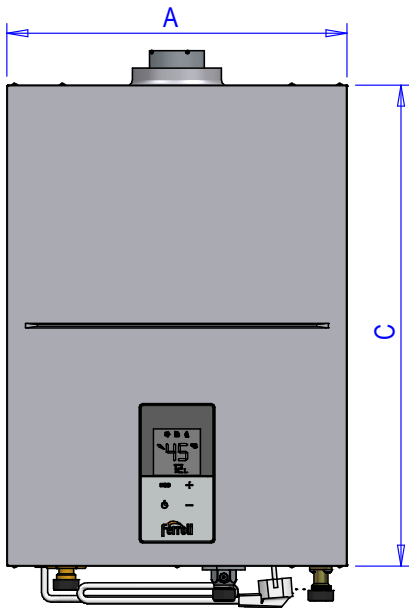

Model	A (mm)	B (mm)	C (mm)	Connections		
				Cold Water	Hot Water	Gas
KONA 12	370	190	525	1/2"		
KONA 15						
KONA 17						

4.2 Overview and main components

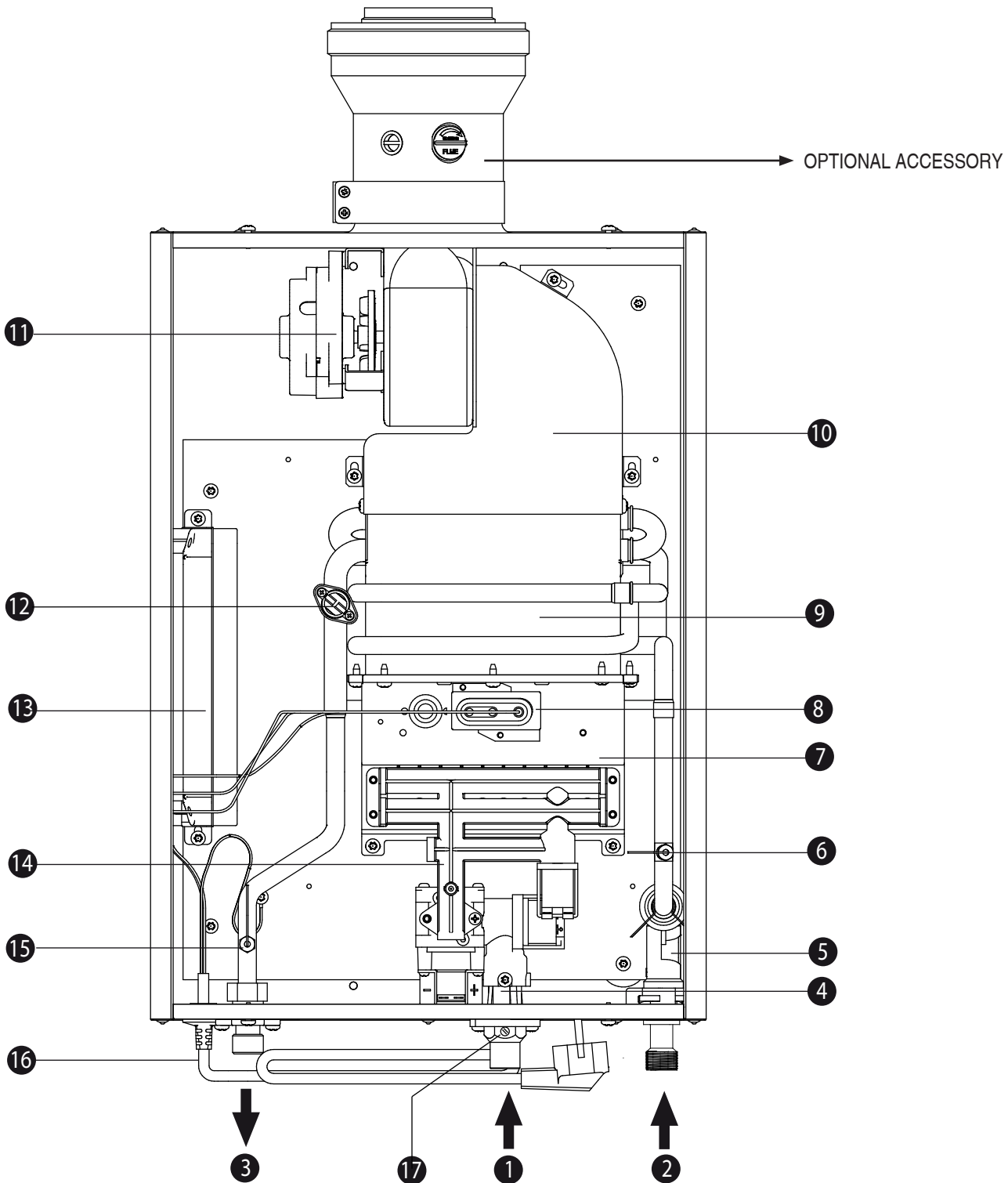

- | | |
|-------------------------------------|-----------------------------------|
| [1] Gas inlet | [9] Copper exchanger |
| [2] Cold water inlet | [10] Smoke chamber |
| [3] Domestic hot water outlet (ACS) | [11] Fan |
| [4] Gas valve | [12] Temperature limiter |
| [5] Flowmeter | [13] Electronic card (PCB) |
| [6] Cold water temperature sensor | [14] Gas collector |
| [7] Burner assembly | [15] Hot water temperature sensor |
| [8] Electrode assembly | [16] Power cable (230 V) |
| | [17] Gas pressure point |

4.3 Technical Data Table

Data	Unit	KONA 12	KONA 15	KONA 17	Notes
CODE	-	ODK96IAA	ODK95IAA	ODK97IAA	G20
		ODK96KAA	ODK95KAA	ODK97KAA	G31
- Unit categories - Destination countries: IT - IE- GB - FR - PL	-	II _{2HM3B/P} (IT) II _{2R3R} (FR) II _{2Esi3P} (FR) II _{2ELwLs3B/P} (PL)	II _{2H3B/P} (IE) II _{2H3P} (GB) II _{2Ei3P} (FR)		
Maximum heat capacity (Hi)	kW	23	29.7	33	Q (Hi)
Minimum heat capacity (Hi)	kW	4	4	4	Q (Hi)
Maximum heat capacity	kW	20.9	27	30	P
Minimum heat capacity	kW	3.6	3.6	3.6	P
Burner injectors G20	N.º x Ø	10 x 0.74 10 x 1.07	16 x 0.75 16 x 1.13	16 x 0.75 16 x 1.13	
G20	Supply pressure G20	mbar	20		
	Maximum Pressure burner G20	mbar	12.5	7.3	9
	Minimum Pressure burner G20	mbar	2.5	3	3
	G20 flow rate – Max / min	m³/h	2.43 / 0.42	3.14 / 0.42	3.49 / 0.42
	CO ₂ – G20 – Max / min	%	5.7 / 1.9	4.4 / 1	4.8 / 1
Burner injectors G25 / G230	N.º x Ø	10 x 0.80 10 x 1.15	16 x 0.85 16 x 1.20	16 x 0.85 16 x 1.20	
G25	Supply pressure G25	mbar	25		
	Maximum Pressure burner G25	mbar	14.5	8.7	10.5
	Minimum Pressure burner G25	mbar	3	3.6	3.6
	G25 flow rate – Max / min	m³/h	2.83 / 0.49	3.66 / 0.49	4.06 / 0.49
	CO ₂ – G25 – Max / min	%	5.7 / 1.9	4.4 / 1	4.8 / 1
G230	Supply pressure G230	mbar	20		
	Maximum Pressure burner G230	mbar	14.8	9.2	11
	Minimum Pressure burner G230	mbar	3.2	3.8	3.8
	G230 flow rate – Max / min	m³/h	1.88 / 0.33	2.43 / 0.33	2.7 / 0.33
	CO ₂ – G230 – Max / min	%	6.5 / 1.9	5 / 1.2	5.4 / 1.2
Burner injectors G30 / G31	N.º x Ø	10 x 0.50 10 x 0.75	16 x 0.47 16 x 0.75	16 x 0.47 16 x 0.75	
G30	Supply pressure G30	mbar	29		
	Maximum Pressure burner G30	mbar	15,5	10,8	12,8
	Minimum Pressure burner G30	mbar	3.8	5,7	5,7
	G30 flow rate – Max / min	kg/h	1,81 / 0,32	2,34 / 0,32	2,6 / 0,32
	CO ₂ – G30 – max/min	%	6,5 / 1,9	5 / 1,2	5,4 / 1,2
G31	Supply pressure G31	mbar	37		
	Maximum Pressure burner G31	mbar	20,5	14,5	18
	Minimum Pressure burner G31	mbar	4.3	7,5	7,5
	G31 flow rate – Max / min	kg/h	1,79 / 0,31	2,31 / 0,31	2,56 / 0,31
	CO ₂ – G31 – Max / min	%	6,5 / 1,9	5 / 1,2	5,4 / 1,2
NOx emission class	-	6 (< 56 mg/kWh)			NOx
Max. operating pressure	bar	10			pw
Min. operating pressure	bar	0.2			
ACS flow rate	Δ 25 ° Max	l/min	12	15.5	17
	Δ 30 ° Max	l/min	10	12.9	14.3
Max operating temp. (configurable via param.)	°C	65			tmax
Protection rating	IP	IPX4D			
Supply voltage	V - Hz	230 V - 50 Hz			
Absorbed electrical power	W	34	36	48	
Empty weight	kg	13.7	14.5	14.5	
Types of unit	-	B32-C12-C22-C32-C42-C52-C62-C82-C92			
CE	-	0085 / 22			
Maximum flue pressure at Pmax	Pa	80			

Brand: FERROLI					
Type of product: Sealed water water heater					
MODEL			KONA 12	KONA 15	KONA 17
KONA M – METHANE			CODE	0DK96IAA	0DK95IAA
KONA LPG – LIQUEFIED PETROLEUM GAS				0DK96KAA	0DK95KAA
Element	Symbol	Unit	Value		
Declared load profile	-	-	XL	XL	XL
Energy efficiency class for water heating (A + a F)	-	-	A	A	A
Daily electricity consumption	Qelec	kWh	0.082	0.082	0.082
Annual electricity consumption	AEC	kWh	18	18	18
Water heating energy efficiency	NWh	%	85	85	85
Daily fuel consumption	Qfuel	kWh	21.052	20.996	20.996
Annual fuel consumption	AFC	GJ	18	18	18
Thermostat temperature settings, as placed on the market	-	-	MAX		
Sound power level, indoors	LWA	dB	54	56	56
Nitrogen oxide emissions	NOx	mg/kWh	32	26	26

4.4 Electrical diagram

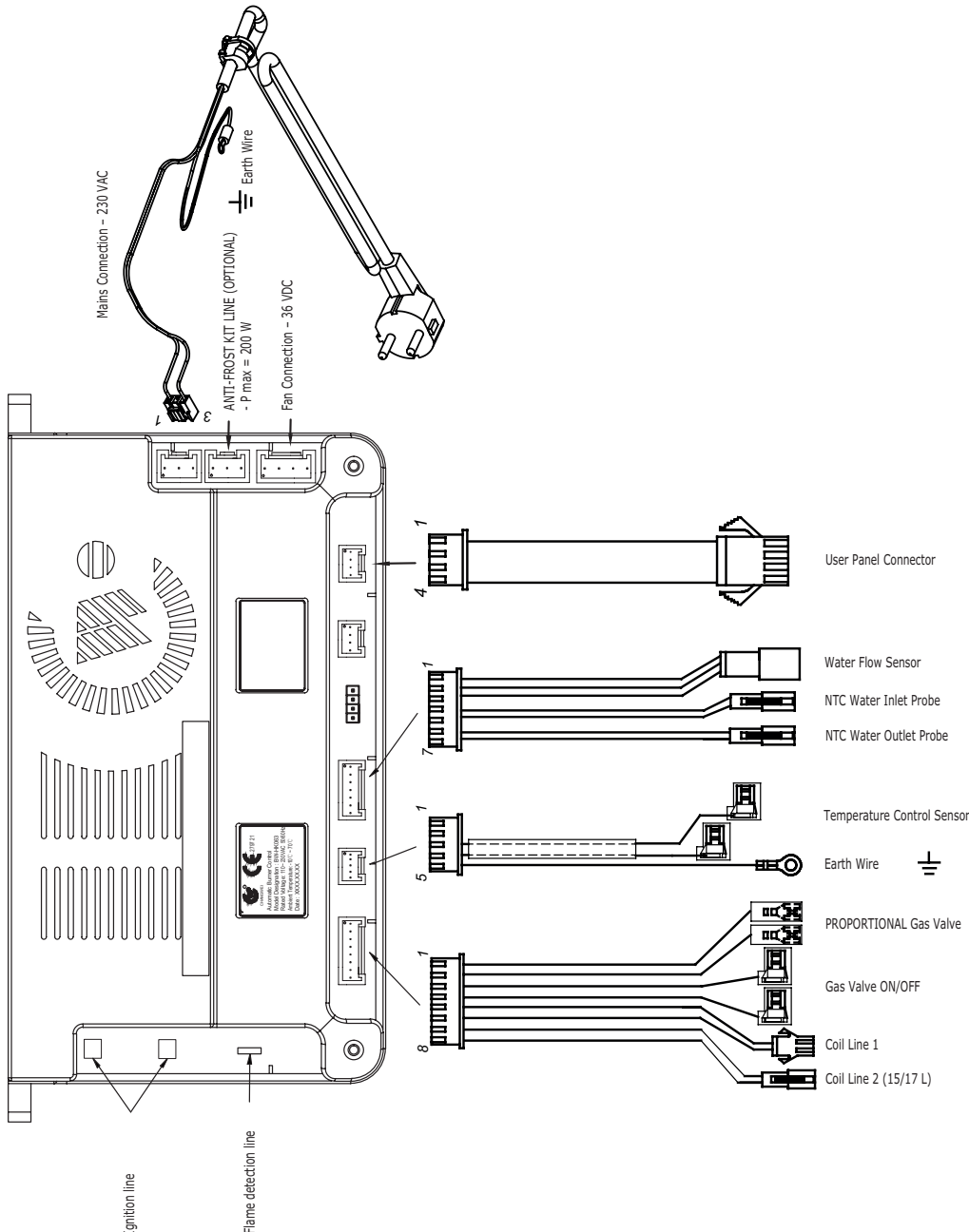



FERROLI S.p.A.

Via Ritonda 78/a

37047 San Bonifacio - Verona - ITALY

www.ferroli.com

Fabbricato in Spagna - Fabriqué en Espagne
Wyprodukowane w Hiszpanii - Made in Spain