

Technical Specification Sheet

GENESIS BN II

GENESIS BN II

dual lever mixer



Specification

Finish	Brushed Nickle
Body	Stainless Steel
Fitting	Deck Mounted
Connections	1/2" M10
Spout Rotation (°)	360

Dimensions

Tap Hole Size (mm)	35
Height (mm)	394.5
Base Width (mm)	55
Reach (mm)	214.9
Weight (kg)	1.15
Box Dimensions (mm)	420 x 225 x 70
Packed Weight (kg)	1.7

Bar Pressure

Minimum Pressure	0.5
Maximum Pressure	3
Maximum Temperature (°C)	60

Flow Rates

@ 0.5 bar	@ 1 bar	@ 3 bar
6.47	9.26	16.3

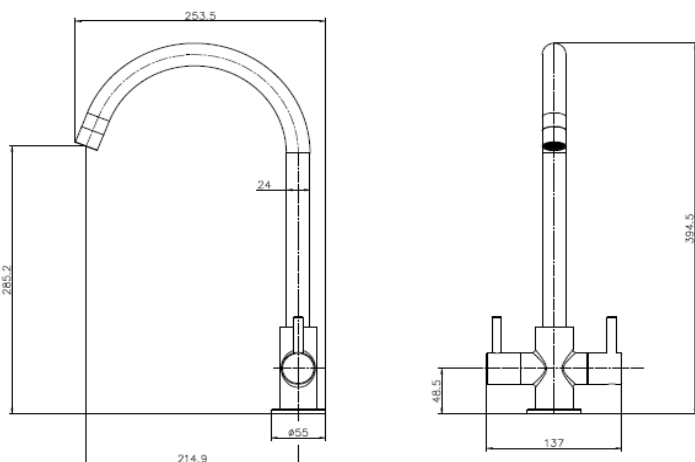

Additional Features/Benefits

Dual lever	
Aerator included	
Suitable for low pressure	
Thread length is 50mm, It can manage 40mm worktops max	
EAN	5060964934259

Warranty

10 Year Warranty (Casting Only)

Care & Maintenance

Reginox recommends cleaning your tap regularly with non-abrasive cleaners. Warm, soapy water would be best.

All pressures are in bar.
 Dimensions supplied are nominal and subject to tolerance.
 Inclusion of aerator (if supplied) or restrictors (supplied separately) will affect flow rate result.
 Performance details are based on trials under test conditions and are for guidance only,
 The manufacturer reserves the right to change product specification without prior notice.

Certifications

