

Multifit

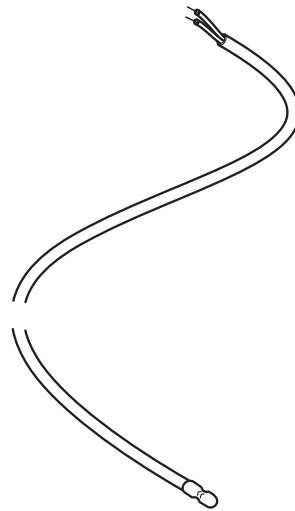

Part No. 7724181

Installation & Commissioning Instructions

IFOS - In Flue Outdoor Sensor Kit
Temperature Compensation Device

**Suitable for Combination boilers fitted in conjunction
with horizontal or vertical flue terminals ONLY &
flue systems up to 4 metres**

(optional extension cable available for longer flues)

These instructions should be read in conjunction with the
Boiler Installation and Service Manual and left with the User when completed.

Please keep these instructions in a safe place.
If you move house please hand them over to the next occupier.

The In Flue Outdoor Sensor is suitable for use with the following boilers:-

BOILER GROUP 'A'

- Baxi Duo-tec Combi range
- Baxi Platinum Combi range
- Main Eco Elite Combi range
- Potterton Promax Combi range
- Potterton Gold Combi range
- Potterton Titanium Combi range

BOILER GROUP 'B'

- Baxi 100 Combi range
- Potterton Promax Ultra Combi range

BOILER GROUP 'C'

- Baxi EcoBlue + Combi & Advance Combi ranges

BOILER GROUP 'D'

- Baxi 200 Combi range
- Baxi 400 Combi range

BOILER GROUP 'E'

- Baxi 600 Combi range
- Baxi 800 Combi range
- Main Eco Compact Combi range
- Potterton Assure Combi range

Refer to the Installation & Service Manual supplied with the appliance if the boiler being installed is not on the above list.

Contents

Section	Page
1.0 Legislation	2
2.0 Introduction	3
3.0 Contents of pack	3
4.0 Fitting the in flue outdoor sensor	4
5.0 Connecting the in flue outdoor sensor boiler group 'A'	7
6.0 Setting the in flue outdoor sensor curve boiler group 'A'	8
7.0 Connecting the in flue outdoor sensor & setting the curve boiler group 'B'	9
8.0 Connecting the in flue outdoor sensor boiler group 'C'	10
9.0 Setting the in flue outdoor sensor parameters boiler group 'C'	10
10.0 Operating instructions in flue outdoor sensor boiler group 'C'	11
11.0 Fault finding boiler group 'C'	12
12.0 Connecting the in flue outdoor sensor & setting the slope boiler group 'D'	13
13.0 Connecting the in flue outdoor sensor & setting the curve boiler group 'E'	14
14.0 High Heat Loss Resistor	15
15.0 User Information	16

ErP Information

Regulation EU811/2013, supplementing Ecodesign and Energy Labelling Directives 2010/30EU		
Part Number	This Thermostatic Control Device is rated	Correction Factor (Contribution to system energy efficiency)
7724184	Class 'II'	2 %

1.0 Legislation

NOTES: This kit is suitable only for installation in GB and IE and should be installed in accordance with the rules in force.

In GB, the installation must be carried out by a Gas Safe Registered Installer. It must be carried out in accordance with the relevant requirements of the:

- Gas Safety (Installation & Use) Regulations.
- The appropriate Building Regulations either:-
The Building Regulations, The Building Regulations (Scotland), Building Regulations (Northern Ireland).
- The Water Fittings Regulations or Water Byelaws in Scotland.
- The Current I.E.E. Wiring Regulations.

Where no specific instructions are given, reference should be made to the relevant British Standard Code of Practice.

In IE, the installation must be carried out by a competent Person and installed in accordance with the current edition of I.S. 813 'Domestic Gas Installations', the current Building Regulations and reference should be made to the current ETCI rules for electrical installation.

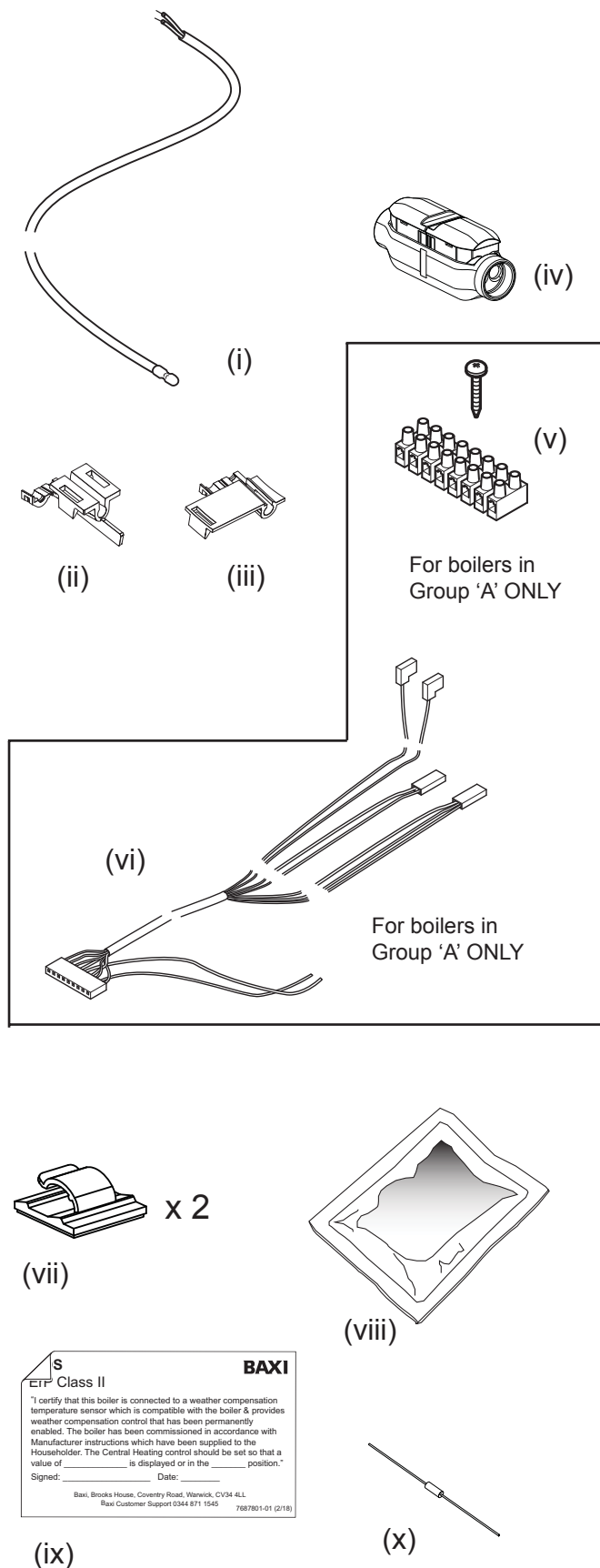

2.0 Introduction

1. The In Flue Outdoor Sensor - IFOS - kit positions a temperature sensor in the horizontal or vertical flue terminal. The flue system can be up to 4 metres of actual length, or a further 5 metres with the optional extension cable. Installation of this kit permits the customer to gain the efficiency benefits of outdoor weather temperature compensation control. The sensor allows the outdoor temperature to be taken into consideration and the boiler flow temperature regulated accordingly to provide required comfort levels.
2. The curve determining boiler flow temperature should be set as low as possible but still maintaining required comfort levels. The selected curve must be noted on the identifying label to be affixed to the boiler.
3. The addition of anything that may interfere with the normal operation of the appliance without express written permission from the manufacturer could invalidate this kit and the appliance warranty. In GB this could also infringe the Gas Safety (Installation and use) Regulations.
4. This kit is only suitable for use with the boiler ranges listed by group on page 2.

IMPORTANT: This kit is for use with horizontal & vertical flue terminals in a flue system of up to 4 metres actual length. A 5 metre sensor cable extension is available as an optional extra. The kit cannot be fitted where other devices such as the MULTIFIT GasSaver are incorporated into the flue system. It is permissible to shorten the cable. If shortening the cable DO NOT cut the sensor end !

Conventional Controls: Standard mains voltage ON/OFF controls do not affect the method of setting the curve or boiler operation when the IFOS is fitted. Conventional controls in conjunction with IFOS represent the simplest solution.

OpenTherm Controls: If an OpenTherm control is also to be connected to the boiler this must be taken into consideration as some devices affect the operation of the boiler control knobs or buttons. Depending on the device used it is possible that the OpenTherm control will assume the role of "master", rendering the boiler controls inoperative or altering their function. It is recommended that the IFOS is fitted and set prior to connecting any OpenTherm device. Consult the instructions supplied with such devices before setting the curve. The Baxi uSense device is recommended for this type of control application.

3.0 Contents of Pack

Description

- (i) In Flue Outdoor Sensor (IFOS) Cable
- (ii) Clip for Horizontal Flue
- (iii) Clip for Vertical Flue
- (iv) Connector for Optional 5 metre Cable Extension
- (v) M2 Terminal Strip & Screw (for boilers in Group 'A' only)
- (vi) Replacement Harness (for boilers in Group 'A' only)
- (vii) 2 x Self Adhesive Routing Clips
- (viii) Cleaning Wipe Sachet
- (ix) Identifying Label
- (x) Resistor for High Heating Loss Applications (for boilers in Group 'E' only)

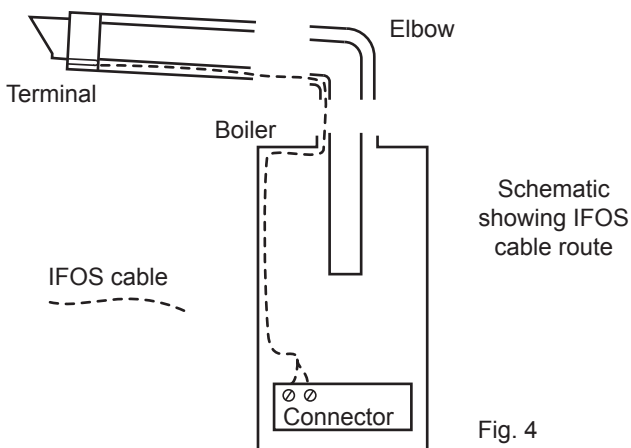
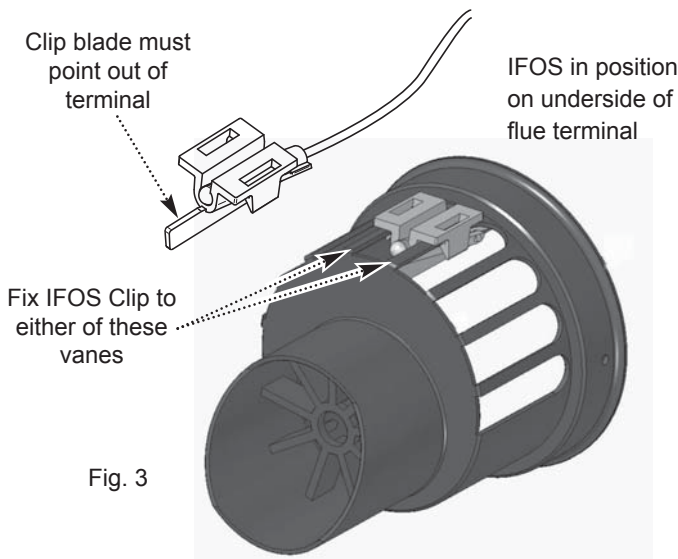
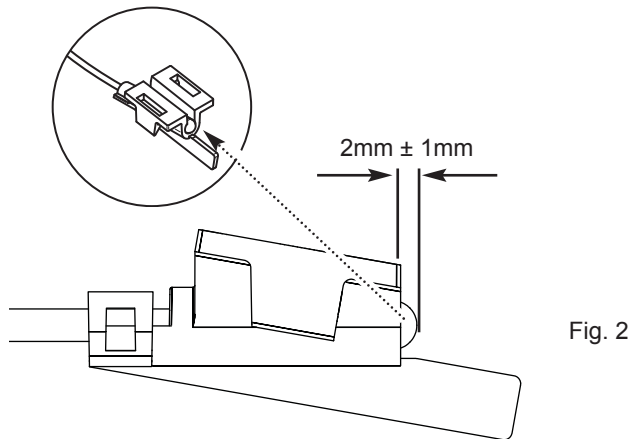
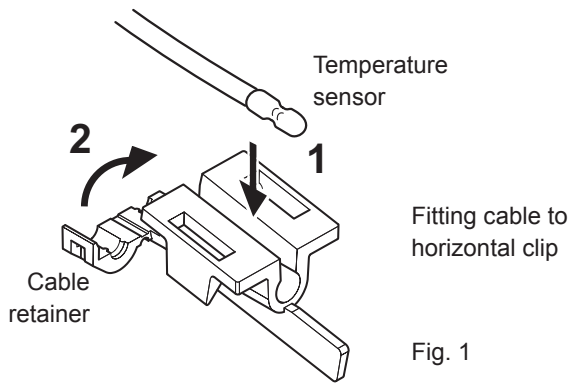

4.0 Fitting the In Flue Outdoor Sensor (IFOS) - Horizontal Flue

1. The IFOS comprises of a length of small diameter flexible 2 core cable. One end is a temperature sensor. The other end has two wires to be connected to the boiler low voltage terminal.

2. The temperature sensor end must be fitted to the clip. Snap the cable retainer into position over the cable (Fig. 1).

NOTE: To ensure effective operation the end of the IFOS sensor must be positioned to protrude 2mm ± 1mm from the body of the clip (Fig. 2).

3. The IFOS must be fixed in the air inlet of the boiler horizontal flue terminal at the time of installation. It **MUST** be positioned as shown (Fig. 3) or to the adjacent vane.

4. Commence the boiler installation as described in the Installation & Service manual to the point where the flue is cut or adjusted and set to length. **Do not cut the flue once the IFOS cable is inserted.**

5. Insert the loose end of the IFOS cable into air inlet of the cut or adjusted flue terminal. Fix the clip to one of the vanes on the air inlet as shown (Fig. 3). Ensure that it is firmly in position.

6. Pull the loose end of the IFOS cable out of the flue air duct.

7. Pass the loose end of the IFOS cable through the air duct of the flue elbow and into the outer part of the boiler adaptor (Fig. 4).

8. Ensure that the IFOS cable is accessible within the boiler and continue to assemble and complete the flue installation.

NOTE: It is recommended that a continuity test is performed on the IFOS cable. A reading of greater than 0Ω indicates continuity.

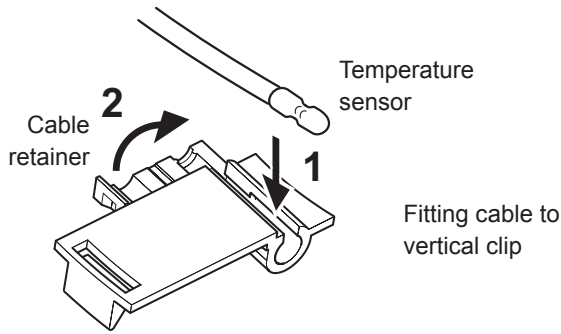

Fig. 5

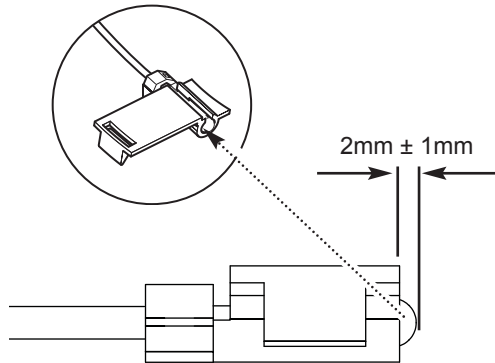

Fig. 6

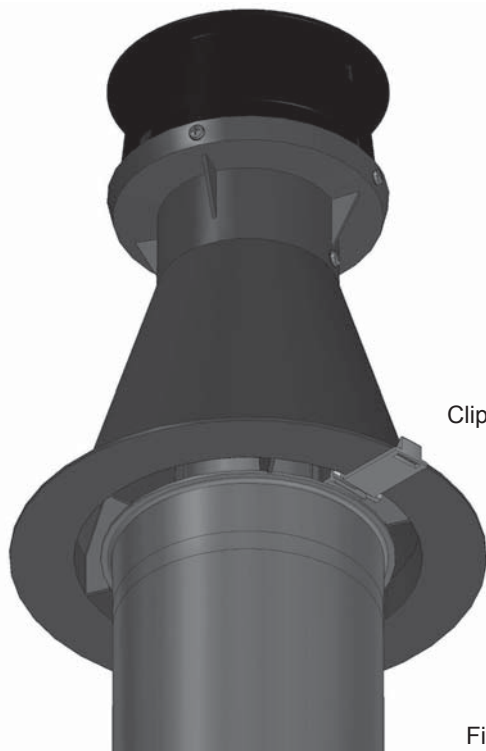

Fig. 7

4.0 Fitting the In Flue Outdoor Sensor (IFOS) - Vertical Flue

9. The IFOS comprises of a length of small diameter flexible 2 core cable. One end is a temperature sensor. The other end has two wires to be connected to the boiler low voltage terminal.

10. The temperature sensor end must be fitted to the clip. Snap the cable retainer into position over the cable (Fig. 5).

NOTE: To ensure effective operation the end of the IFOS sensor must be positioned to protrude 2mm ± 1mm from the body of the clip (Fig. 6).

11. The IFOS must be fixed in the air inlet of the boiler vertical flue terminal at the time of installation. It **MUST** be positioned as shown (Fig. 7).

12. Commence the boiler installation as described in the Installation & Service manual to the point where the flue is cut or adjusted and set to length. **Do not cut the flue once the IFOS cable is inserted.**

13. Insert the loose end of the IFOS cable into the air inlet of the cut or adjusted flue terminal. Fix the clip to the flange as shown (Fig. 7). Ensure that it is firmly in position.

14. Pull the loose end of the IFOS cable out of the flue air duct.

15. Pass the loose end of the IFOS cable into the outer part of the boiler adaptor (Fig. 8).

16. Ensure that the IFOS cable is accessible within the boiler and continue to assemble and complete the flue installation.

NOTE: It is recommended that a continuity test is performed on the IFOS cable. A reading of greater than 0Ω indicates continuity.

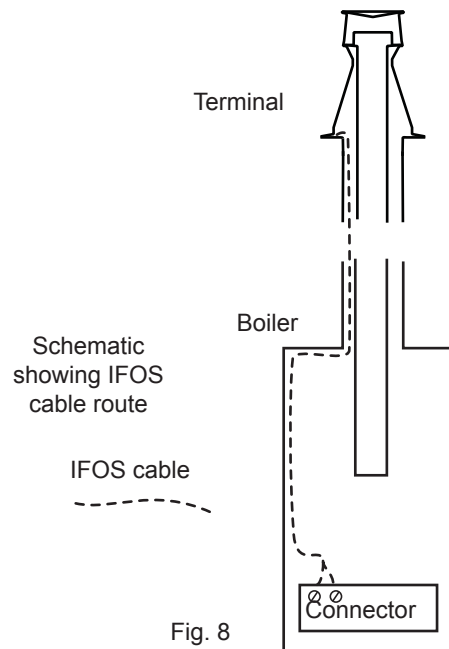

Fig. 8

Fix Routing Clip to inner face of top panel - typical example shown. Depending on boiler model it may be desirable to route the cable to the left.

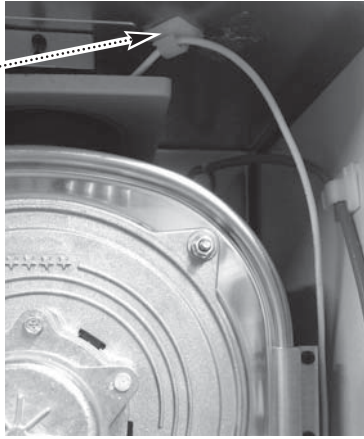

Fig. 9

4.0 Fitting the In Flue Outdoor Sensor (IFOS) - Completion

17. Using the wipe provided clean an area on the inner face of the top panel. Fix one of the self adhesive routing clips to the panel (Fig. 9).

18. Route the IFOS cable through the boiler ensuring that it does not touch any hot surfaces or is adjacent to moving parts, e.g. fan. The second routing clip will assist this.

NOTE: Depending upon boiler type and position of the connection terminals the cable can be run to either the left or right.

Extending the cable - Horizontal & Vertical

19. On longer flue runs (over 4 metres) it will be necessary to extend the IFOS cable using the available cable extension (part no. 7724260, Fig. 10).

20. Take the connector supplied, item (iv) in section 3.0. Ensure that the connector is fully open and insert the IFOS cable wires into one end and the extension cable wires in the other.

21. Press the connector together to retain and connect the cables (Fig. 11).

IMPORTANT: Care must be taken to not damage the cable when securing flue extensions especially if drilling holes for screws.

22. On shorter runs if there are several elbows in the flue (Fig. 11a) it is permissible to cut the standard IFOS cable and use the extension connector to ease installation.

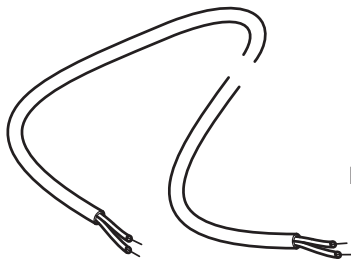

Fig. 10

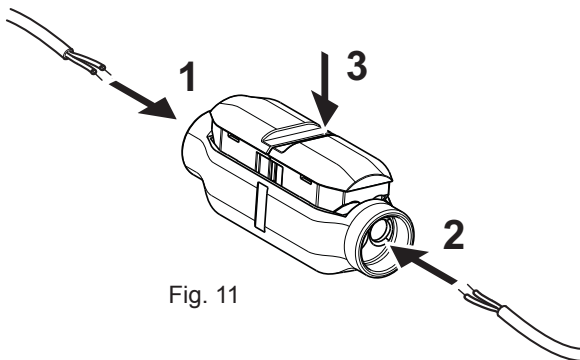

Fig. 11

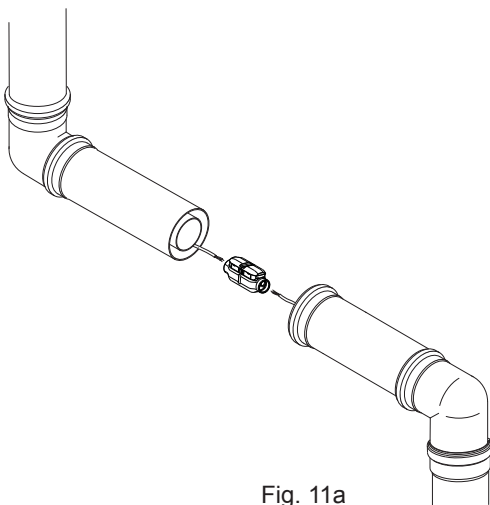

Fig. 11a

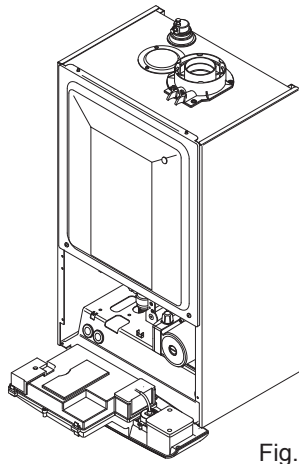

Fig. 13

3 way grommet

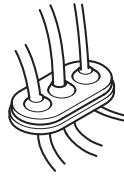

Fig. 12

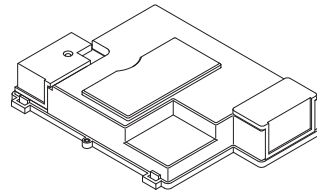

Fig. 14

M2 low voltage terminal strip

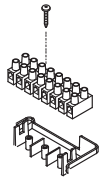

Fig. 15

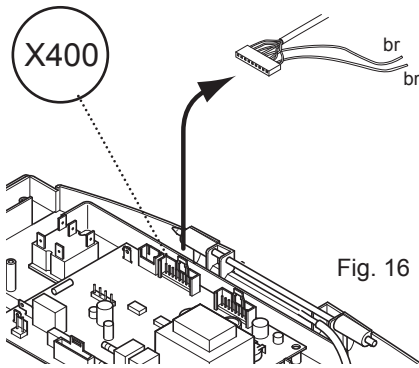
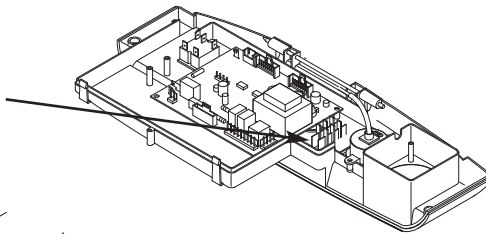

Fig. 16

Combi Hall Effect Sensor

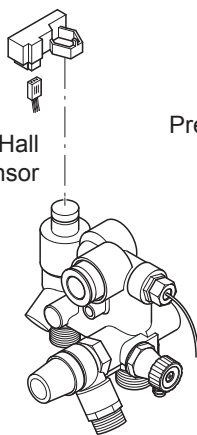

Fig. 17

Combi Water Pressure Switch & DHW NTC

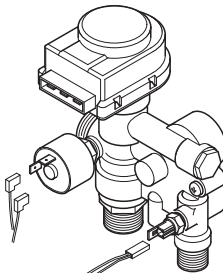

Fig. 18

Brown Wires from New Harness (X400)

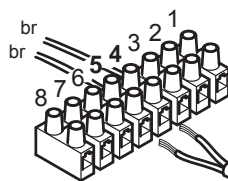

Fig. 19

IFOS Cable

5.0 Connecting the Sensor - boiler Group 'A'

1. Ensure that the electrical supply to the boiler is isolated. Allow the facia to drop down (Fig. 13). Route the IFOS cable through the 3 way grommet (Fig. 12) in the combustion box lower panel.
2. Undo the screws securing the cover and release the cover retaining barbs from their slots. Disengage the rear of the cover from the facia hinge pin and lift the cover away (Fig. 14).
3. Do not touch the PCB unnecessarily, and take care when removing and fitting connectors. The use of an earthing wristband is recommended.
4. Engage the M2 low voltage 8 way terminal strip over the vertical flanges and secure with the screw supplied (Fig. 15).
5. Disconnect the harness connector from position X400 on the PCB (Fig. 16).
6. Disconnect the wiring from the Hall Effect Sensor, DHW NTC and Water Pressure Switch (Figs. 17 & 18). Retain the Hall Effect Sensor.
7. Connect the new harness supplied to position X400 on the PCB.
8. Connect the harness terminals to the Hall Effect Sensor, DHW NTC and Water Pressure Switch (see Figs. 17 & 18). Refit the Hall Effect Sensor.
9. Connect the two brown wires on the new harness to 4 & 5 on the M2 low voltage 8 way terminal strip (Fig. 19).
10. Connect the IFOS cable to 4 & 5 on the M2 low voltage 8 way terminal strip (Fig. 19). There is no polarity.

Note the boiler setting on the identifying label supplied. It must then be signed and affixed to the front of the boiler or inside the control cover facia. The label must be readily accessible without removing the boiler casing or any other disassembly. This label is required to enable SAP/energy assessors to identify that a weather compensation device is installed.

11. Refit the cover, resecure the facia and door panel.

6.0 Setting the Sensor Curve - boiler Group 'A'

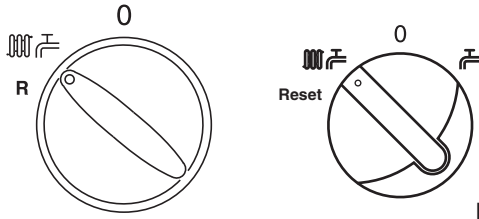

Fig. 20

NOTE: Depending upon model of boiler different types of Selector Switch and Central Heating Control Knob will be fitted (Figs. 20 & 21).

1. Ensure that there is power to the boiler (though it is not necessary for there to be any heating demand). Turn the Selector Switch (Fig. 20) to the boiler ON (central heating & domestic hot water) position.

2. The Central Heating Control Knob should be turned clockwise to the position in Fig. 21 which corresponds with the desired curve as shown on the graph below.

3. Normally the display will show the current temperature of the water in the boiler (e.g. 41°C, Fig. 22). As the knob is turned the display will show the selected curve (Fig. 23).

For example, if Curve '35' is selected (Fig. 23), at an outside temperature of 0°C the boiler flow temperature will be 80°C.
Consider the type of dwelling and discuss with the user their requirements to determine the most appropriate curve.

4. Explain to the user how to select a different temperature curve.

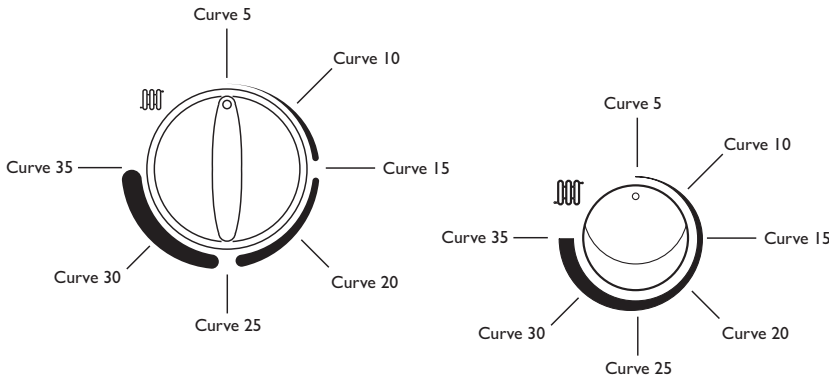

Fig. 21

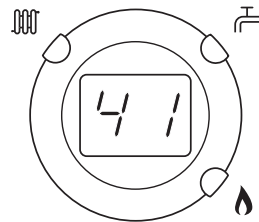
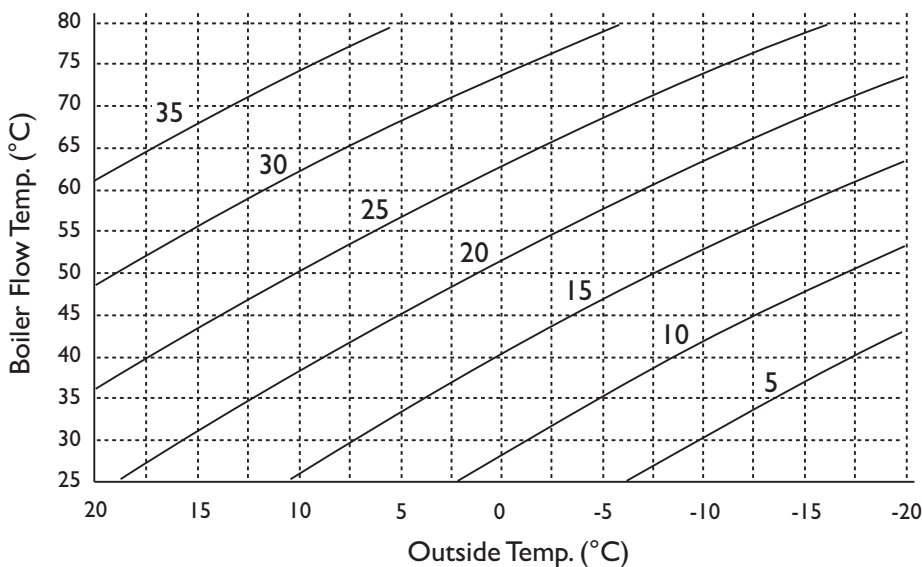

Fig. 22



Fig. 23



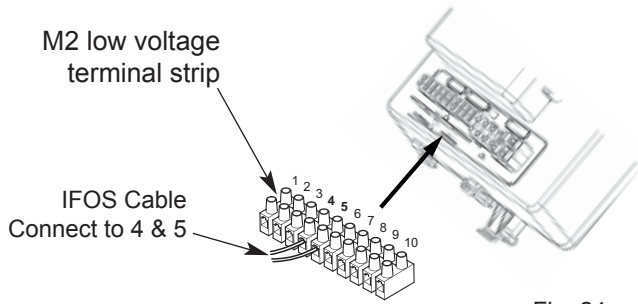

Fig. 24

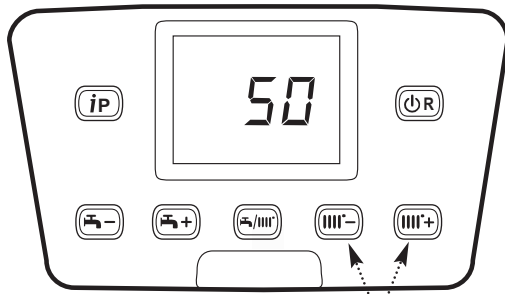

Fig. 25

Central Heating
Temperature
Adjustment Buttons

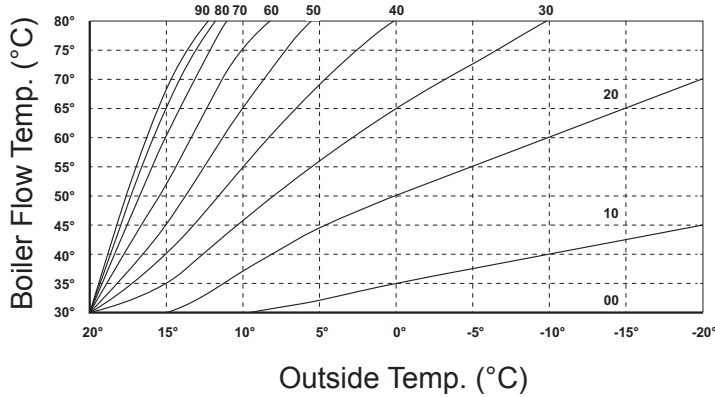

Fig. 26

7.0 Connecting the Sensor & Setting the Curve - boiler Group 'B'

Connecting

1. Ensure the electrical supply to the boiler is isolated. Undo the securing screws and lift the case front panel off.
2. Disengage the securing tab and hinge the control box downwards. Undo the terminal block cover securing screw and remove the cover.
3. Connect the IFOS cable to 4 & 5 on the M2 low voltage 10 way terminal strip (Fig. 24) then refit the cover. There is no polarity.

Note the boiler setting on the identifying label supplied. It must then be signed and affixed to the front of the boiler or inside the control cover facia. The label must be readily accessible without removing the boiler casing or any other disassembly. This label is required to enable SAP/energy assessors to identify that a weather compensation device is installed.

Setting

4. Ensure that there is power to the boiler.
5. The Central Heating temperature buttons **||||-** & **||||+** are used to select the desired curve as shown on the graph.
6. Normally the display will show the current temperature of the water in the boiler (e.g. 41°C). As the buttons are pressed (Fig. 25) the curve identification code will be shown, from '00' to '90'.

For example, if Curve '40' is selected (Fig. 26), at an outside temperature of 0°C the boiler flow temperature will be 80°C. Consider the type of dwelling and discuss with the user their requirements to determine the most appropriate curve.

7. Explain to the user how to select a different temperature curve.

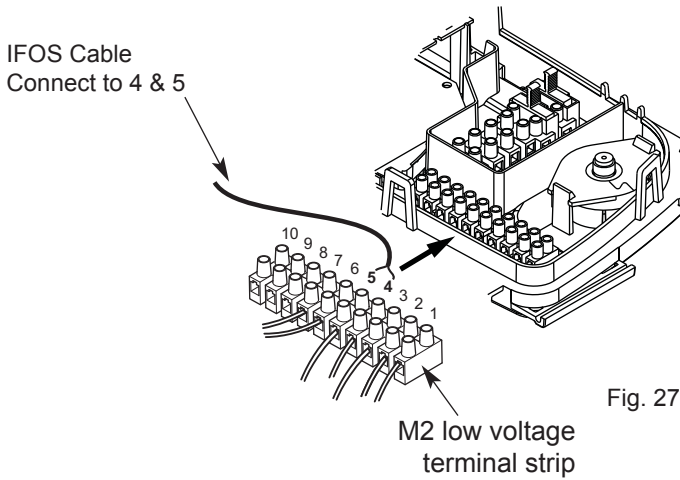

Fig. 27

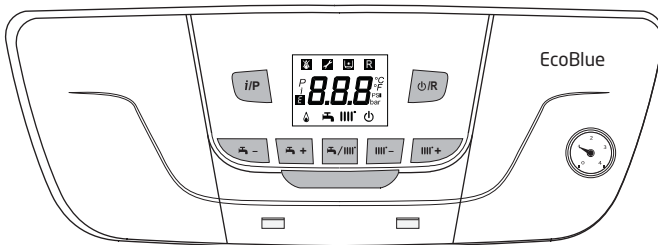

Fig. 28

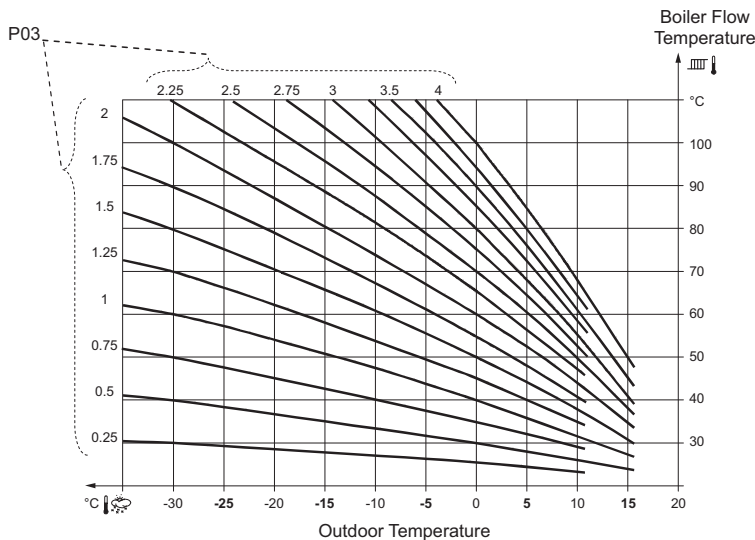

Fig. 29

Consider the type of dwelling and discuss with the user their requirements.

8.0 Connecting the Outdoor Sensor - boiler Group 'C'

1. Ensure that the electrical supply to the boiler is isolated. Hinge down the control box and remove the boiler terminal block cover.
2. Connect the IFOS cable to 4 & 5 on the M2 low voltage 10 way terminal strip (Fig. 27). There is no polarity.

Note the boiler setting on the identifying label supplied. It must then be signed and affixed to the front of the boiler or inside the control cover facia. The label must be readily accessible without removing the boiler casing or any other disassembly. This label is required to enable SAP/energy assessors to identify that a weather compensation device is installed.

3. Refit the boiler terminal block cover, hinge back the control box and replace the boiler case.

9.0 Setting the parameters for the outdoor sensor - boiler Group 'C'

With the IFOS fitted, the boiler central heating flow temperature is adjusted automatically to accommodate the change in heat required to optimise the efficient performance of the boiler whilst maintaining a comfortable room temperature. The central heating buttons on the boiler adjust a "simulated room temperature" used for this optimisation.

This functionality requires the setting of three parameters on the boiler, to suit the heating system and the optimisation can be adjusted by the user with the central heating control buttons on the boiler control panel.

The parameters which must be set are:

P06 = Minimum CH Flow temperature. This should be set to the lowest temperature at which the heat emitters are effective.

P07 = Maximum CH Flow temperature. This should be set to the highest flow temperature which can be permitted in the CH circuit.

P03 = Heating curve (Fig. 29). This should be calculated using the following formula:

$$\text{where: } P03 = \frac{P07 - T_{room}}{T_{room} - T_{outmin}}$$

T_{room} = The normal room thermostat setting used by the customer (if this is in doubt or unknown use 20°C), and the temperature to be set on the boiler.

T_{outmin} = The minimum expected outdoor temperature, as used for sizing the heating system (recommended value -5°C)

NOTE: parameter P03 can be set to a value in the range 0 - 4 in increments of 0.02.

9.0 Setting the parameters for the outdoor sensor (cont) - Group 'C'

Example Parameter Recommendations:

Radiator systems (Fig. 30):

P03 = 2.4

P06 = 50°C

P07 = 80°C

If the IFOS is fitted to a boiler serving a low temperature system or underfloor heating please contact Baxi Customer Support for advice.

IMPORTANT: Do not change any other parameters other than those described in these instructions otherwise the warranty of this kit and the boiler could be invalidated.

The parameters are set as follows (See Fig. 28):

1. Ensure that there is power to the boiler.
2. Press and hold **||||-** and **||||+** until P02 is displayed on screen.
3. Press and hold **i/P** until On is displayed.
4. Press **||||-** or **||||+** to scroll until the required parameter is displayed.
5. Press **i/P** to edit the program.
Press **||||-** or **||||+** to change the setting to the desired value.
Press **i/P** to confirm selection.
6. Repeat steps 4 and 5 as required for each parameter.
7. When parameter changes are complete press **⏻/R** to return to the normal operating screen.

NOTE: If at any time when setting parameters an error is made or it is desired to restart the process press **⏻/R**.

10.0 Operating instructions with outdoor sensor - boiler Group 'C'

1. While there is no DHW demand the boiler flow temperature is limited according to the heating curve setting
2. If the **||||+** or **||||-** are pressed while CH is enabled, the display shows a simulated room temperature set point. Ensure that this set point is the same as the room thermostat to ensure optimal outdoor weather temperature compensation operation. The user can adjust this temperature should the optimisation not suit their requirements.
3. While DHW is enabled, if the **🔥+** or **🔥-** buttons are pressed, the display will show the DHW temperature set point.
4. Explain to the user how to select a different temperature slope.

Radiator Example

$$P03 = \frac{P07 - T_{room}}{T_{room} - T_{outmin}} = \frac{80 - 20}{20 - (-5)} = 2.4$$

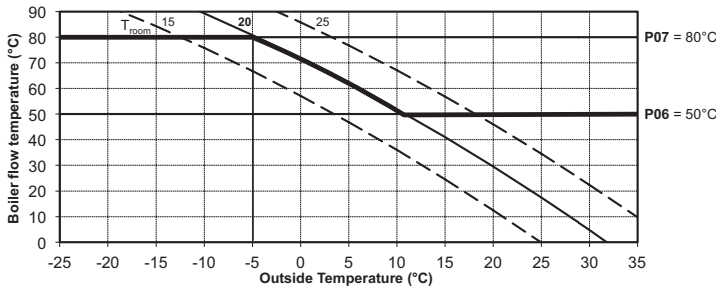
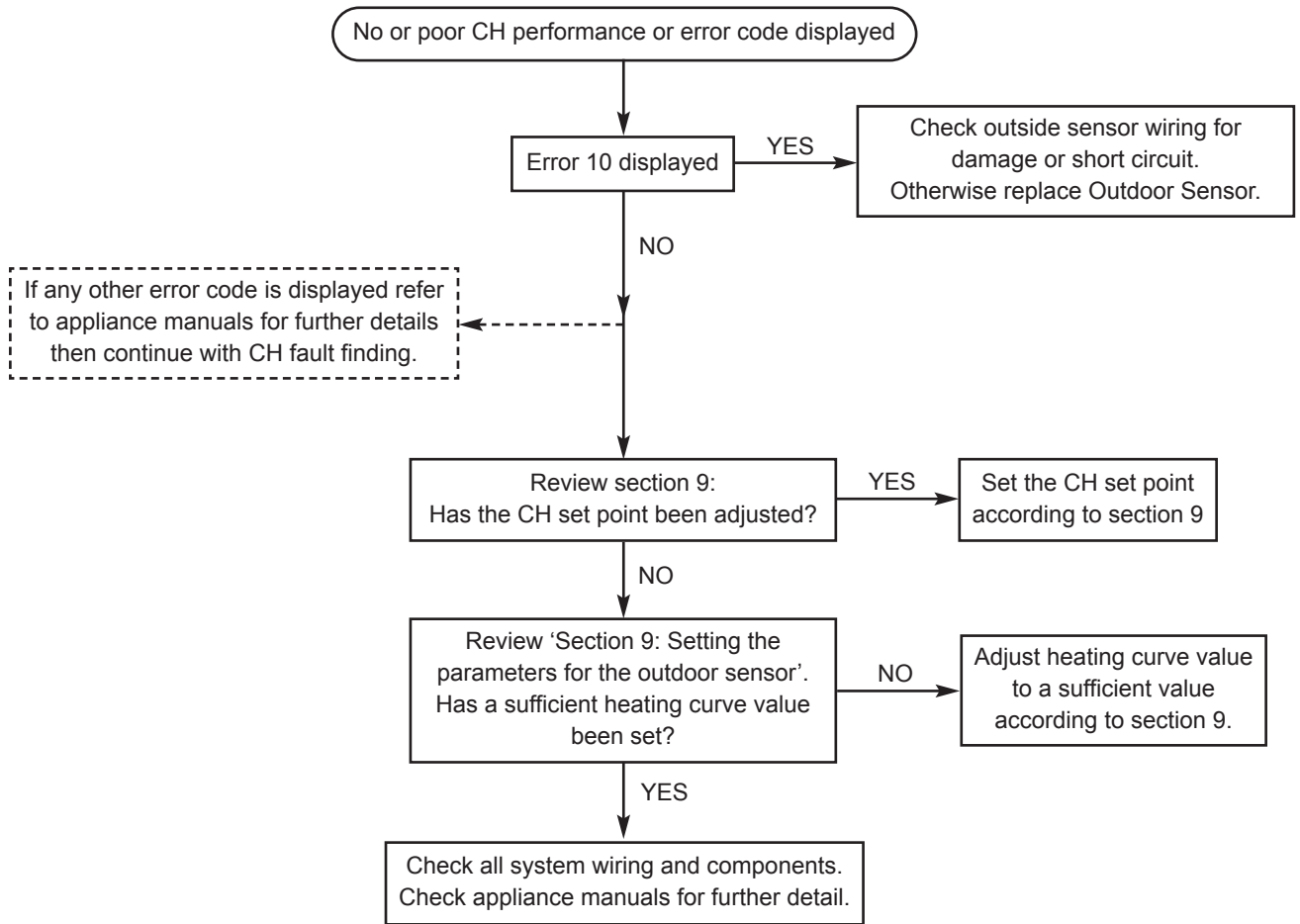

Fig. 30

11.0 Fault Finding - boiler Group 'C'



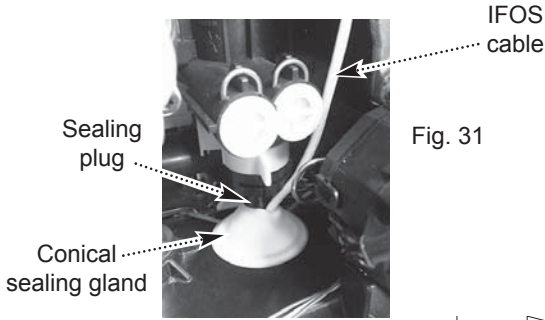

Fig. 31

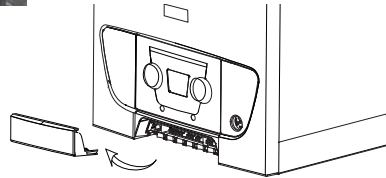

Fig. 32

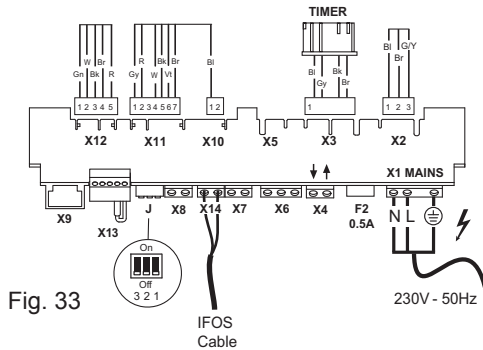

Fig. 33

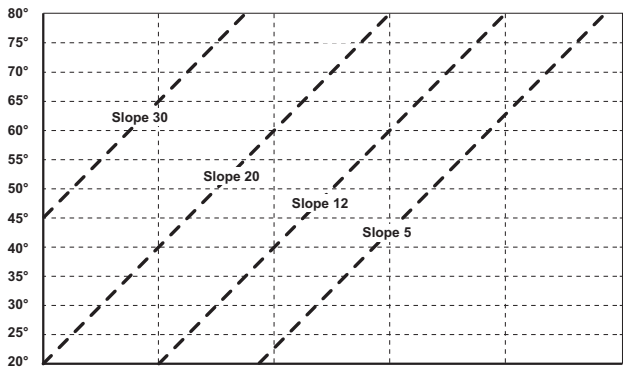

Fig. 34

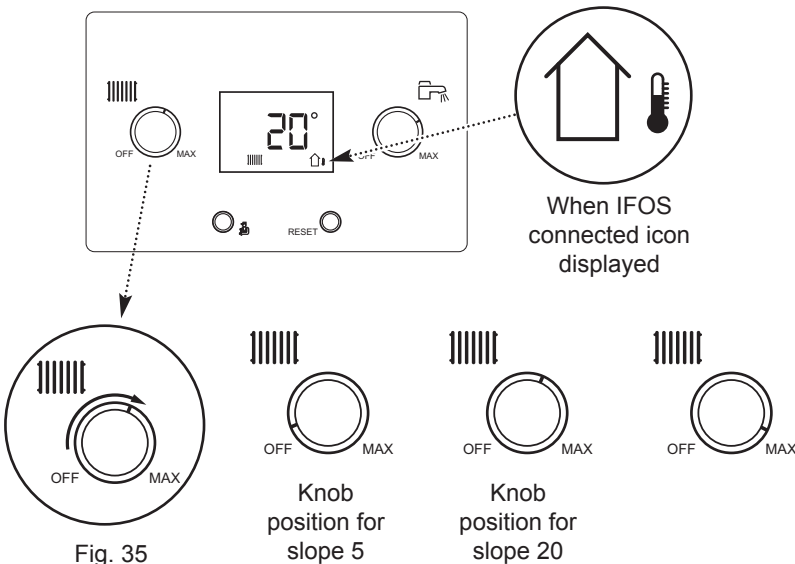

Fig. 35

12.0 Connecting the Sensor & Setting the Slope - boiler Group 'D'

Connecting

1. Ensure the electrical supply to the boiler is isolated.

The IFOS cable must be routed via the conical sealing gland in the lower panel (Fig. 31). Remove the plug from the top of the gland and pass the cable through the gland. Refit the plug to ensure a seal. Within the boiler the cable should be routed to the left side.

2. Fully undo the two screws retaining the electrical cover at the bottom of the front panel. Remove the cover (Fig. 32).

3. Connect the IFOS cable to the grey T-OUT connector (X14 Fig. 33). There is no polarity. Refit and secure the cover.

Note the boiler setting on the identifying label supplied. It must then be signed and affixed to the front of the boiler or inside the control cover facia. The label must be readily accessible without removing the boiler casing or any other disassembly. This label is required to enable SAP/energy assessors to identify that a weather compensation device is installed.

Setting

4. Ensure that there is power to the boiler (though it is not necessary for there to be any heating demand).

5. The Central Heating Control Knob should be turned clockwise until the value which corresponds with the desired slope (as shown on the graph - Fig. 34) is displayed (Fig. 35).

NOTE: If a Baxi uSense smart thermostat is connected to the boiler the slope must be set using the uSense App. The boiler display will not show the slope but will still be active.

6. Normally the display will show the current temperature of the water in the boiler (e.g. 41°C). As the knob is turned the display will show the selected slope (Figs. 34 & 35).

For example, if Slope '12' is selected (Fig. 34), at an outside temperature of 0°C the boiler flow temperature will be 80°C. Consider the type of dwelling and discuss with the user their requirements to determine the most appropriate curve.

7. Explain to the user how to select a different temperature slope.

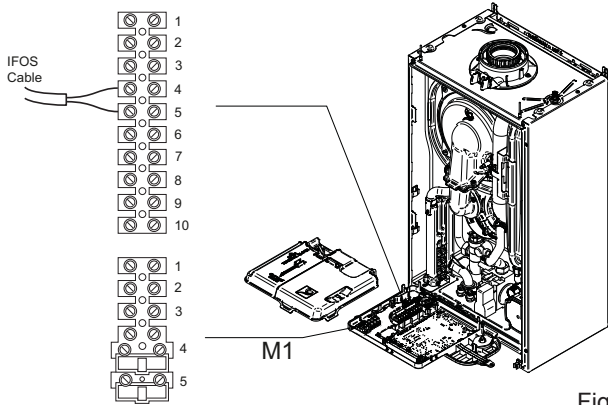

Fig. 36

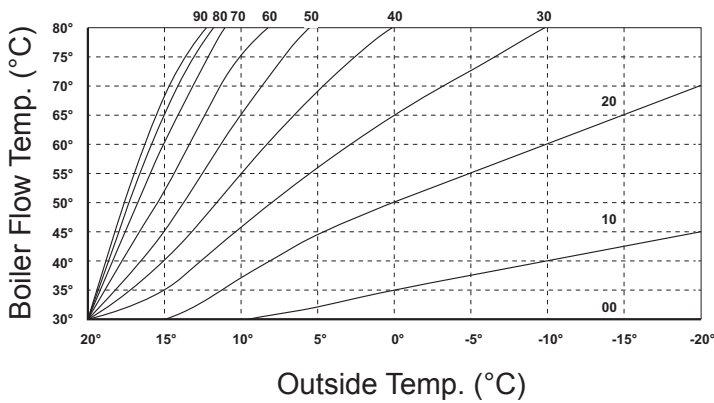

Fig. 37

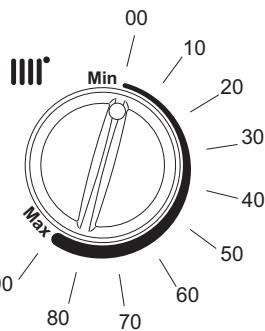

Fig. 38

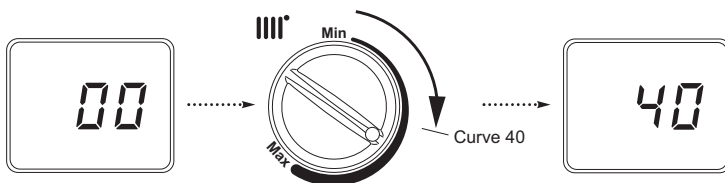

Fig. 39

13.0 Connecting the Sensor & Setting the Curve - boiler Group 'E'

Connecting

1. Ensure the electrical supply to the boiler is isolated.
2. Hinge down the control box and unclip the terminal block cover (Fig. 36).
3. Connect the IFOS cable to 4 & 5 of terminal M2 (Fig. 36).
4. Leave sufficient slack in the cable to allow the control box to be hinged fully open then tighten the gland nut.
5. Refit and secure the cover.

Note the boiler setting on the identifying label supplied. It must then be signed and affixed to the front of the boiler or inside the control cover facia. The label must be readily accessible without removing the boiler casing or any other disassembly. This label is required to enable SAP/energy assessors to identify that a weather compensation device is installed.

Setting

1. Ensure that there is power to the boiler (though it is not necessary for there to be any heating demand).
2. The central heating control knob should be turned clockwise to the position which corresponds with the desired curve as shown on the graph (Fig. 37).

For example, if Curve '40' is selected (Fig. 37), at an outside temperature of 0°C the boiler flow temperature will be 80°C. Consider the type of dwelling and discuss with the user their requirements to determine the most appropriate curve.

NOTE: If a Baxi uSense smart thermostat is connected to the boiler the curve must be set using the uSense App.

3. Normally the display will show the current temperature of the water in the boiler. As the knob is turned the display will show the selected curve (Fig. 38 & 39).

4. Explain to the user how to select a different temperature curve.

14.0 Resistor for High Heat Loss Applications - For use with boilers in groups 'B' & 'E' ONLY !

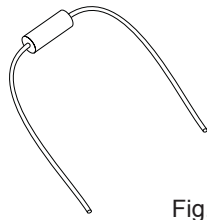

Fig. 40

Introduction

1. The addition of this resistor (Fig. 40) allows the boiler to achieve higher flow temperatures for a given outside temperature when compared with the standard outdoor sensor.

2. It is intended for applications where higher temperatures are required in the dwelling whilst retaining the benefit of weather compensation.

Fitting (Fig. 41)

3. Isolate the power to the boiler.

4. Remove the front panel, hinge down the control box and unclip the terminal block cover.

5. Identify the low voltage terminal block M2.

6. Connect the IFOS cable to terminals 4 & 6. Connect one end of the High Heat Loss resistor to terminal 5.

7. Connect the other end of the resistor to terminal 6 with the IFOS cable.

8. Ensure all terminal screws are tight and reassemble the boiler.

9. Reinstate the power supply.

10. Set the boiler as described in Section 7.0 (boiler group 'B') or section 13.0 (boiler group 'E') to correspond with the desired curve as shown on the graph (Fig. 42).

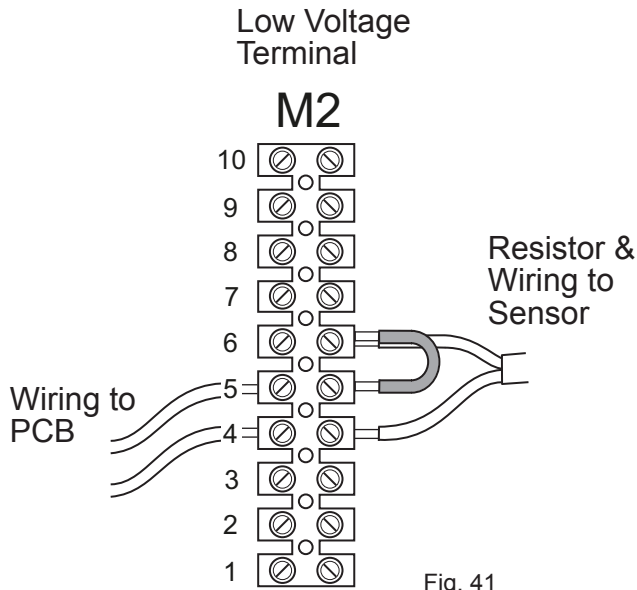

Fig. 41

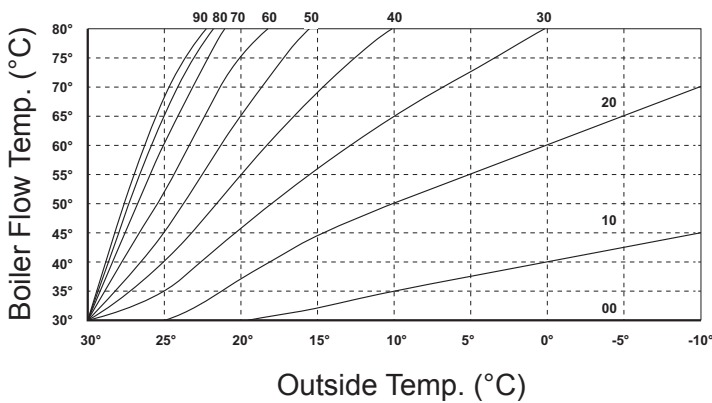

Fig. 42

Graph - Resistor Fitted

For example, if Curve '40' is selected (Fig. 42), at an outside temperature of 10°C the boiler flow temperature will be 80°C. Consider the type of dwelling and discuss with the user their requirements to determine the most appropriate curve.

NOTE: Boiler group 'B' - when using the *iP* button to select the outside temperature on the display the value shown will be 10°C LESS than the actual temperature.

15.0 User Information

NOTE: The Central Heating Temperature Control will NOT operate in the same way as described in the User Instructions supplied with the boiler !

1. Your installation has been fitted with an In Flue Outdoor Sensor (IFOS) that acts as a Temperature Compensation Device.
2. The IFOS enables the boiler to respond effectively to changes in the ambient temperature outside the dwelling.
3. As the outside temperature decreases, the boiler flow temperature will increase, thus maintaining comfort levels within the dwelling.
4. Your installer will have set the boiler according to the anticipated outside temperature range.
5. If you require a different comfort level consult your installer or follow the instructions in this booklet. See the list on page 2 to determine which Section is relevant. Do not attempt to adjust the boiler if you are unsure how to proceed !

Baxi Customer Support



0344 871 1545



Baxi
Brooks House,
Coventry Road,
Warwick, CV34 4LL



baxi.co.uk



e&oe

All descriptions and illustrations provided in this document have been carefully prepared but we reserve the right to make changes and improvements in our products which may affect the accuracy of the information contained in this leaflet. All goods are sold subject to our standard Conditions of Sale which are available on request.