

# Mono Basin Mixer

## Fitting instructions

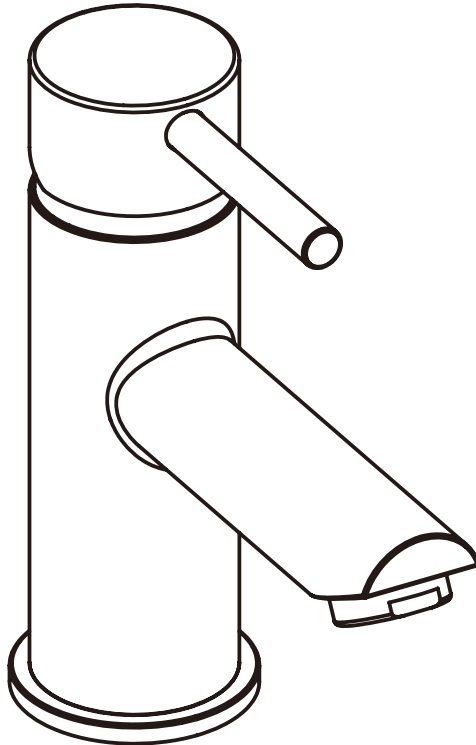

**Please note: Tap head shown is for illustration purposes only.  
Please keep these instructions for future reference and request of replacement parts.**

We have taken great care to ensure that this product reaches you in perfect condition. However should any parts be damaged or missing please contact your point of purchase. This does not affect your statutory rights. In addition if you require replacement parts your point of purchase will be happy to assist.

<b>Contents</b>	<b>Page</b>
<b>1. Tools required</b>	<b>3</b>
<b>2. Parts Supplied</b>	<b>3</b>
<b>3. Specifications</b>	<b>3</b>
<b>4. Installation</b>	<b>4</b>
<b>5. Aftercare</b>	<b>4</b>

## Tools required (Tools not supplied)

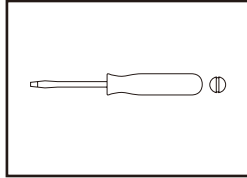
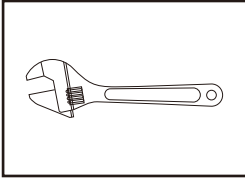

## Parts Supplied

NO.	Description	Qty
1	Tap Body	1
2	Flange (if supplied)	1
3	Sealing Washer	1
4	Fixing Studs	2
5	Rubber Horseshoe Washer	1
6	Metal Horseshoe Washer	1
7	Fixing Nuts	2
8	Braided Connectors	2

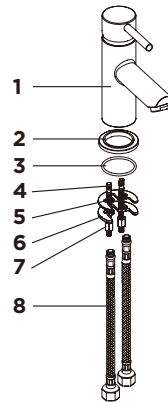

## Specifications

The tap is suitable for use at water supply pressures of 0.3 bar (min.) to 5 bar (max.). BS 8558 recommends hot water should be stored and distributed at a temperature of not less than 60°C which will help minimise the build-up of limescale. For further details contact your Local Water Authority.

This taps should be installed in compliance with the Water Regulations.

- (a) Identify all components and check pack contents.
- (b) Turn off water mains supply.

# Installation

1. Fit Fixing Studs (4) to Tap Body (1) and tighten it.
2. Make sure that Sealing Washer (3) has been fitted to Flange (2). Fit Flange (2) to the Tap Body (1). if the Flange (2) is not supplied, fit Sealing Washer (3) directly to the Tap Body (1).
3. Screw 2x Braided connectors (8) into Tap Body (1) through the hole of flange, do not over tighten.
4. Locate the tap assembly down through the tap hole in basin.
5. Fit Rubber Horseshoe Washer (5) and Metal Horseshoe Washer (6) onto the Fixing Studs (4). And then fix Fixing Nuts (7) onto the Fixing Studs (4). Do not over tighten.
6. Fit Braided Connectors (8) to the water supply using suitable plumbing joints.
7. Turn on the hot and cold and mains water supply. Check for leaks immediately. It is always advisable at this stage to flush out the system. To do this, open both valves fully and allow water to flow for approx. 1 minute. This will remove any foreign matter within the installation.
8. Finally turn on all the water heating arrangements.

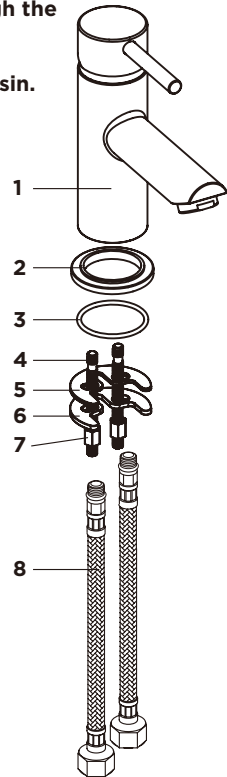

# Aftercare

Whilst modern plating techniques are used in the manufacture of these fittings, the plating will wear if not cleaned properly. The safest way to clean your product is to wipe with a soft damp cloth. Stains can be removed using washing up liquid. All cleaning powders and liquids will damage the surface of your fitting even the non-scratch cleaners.