

# Caspian® UV

Education | Healthcare | Places of worship | Leisure and sport | Office | Hospitality | Retail | Showroom | Industrial | Residential



## One heating solution, suitable for high, low or ceiling mounted applications

Caspian fan convectors are both a practical and high quality heating solution for any commercial project

Incorporating the latest EC motor technology, which can result in running-cost savings as high as 70%, and with variable speed control as standard, the Caspian delivers heat quickly and quietly

It is possible to have master and slave Caspian fan convectors that integrate the entire range of EC Caspian products. Please contact either our sales team or technical team to ensure that this is correctly specified

Caspian are compatible with most types of wet central heating systems, functioning equally efficiently with conventional boilers, biomass technology or ground or air source heat pumps

The airflow can be reversed so that the warm air is discharged from the lower vent. Please contact either our sales team or technical team to ensure that the correct inlet/discharge positioning is specified

Available with [Smart Control](#) and [Antibacterial paint](#)

## Product Information

### Motor

EC (BMS compliant).

### Finish

Casing: zinc-coated steel 1.2mm .

Polyester powder-coated: white RAL 9010.

Available to special order in any colour and with anti-microbial or antibacterial paint.

### Filter

Class G2, 100% polyester, non-washable.

### Installation

Suitable for two-pipe central heating systems.

Maximum installation height for high or ceiling mounting - 4m to underside.

Pipework access holes on the rear and underside.

Key operated front access panels.

Bleed valve accessible on removal of front casing.

Unit must be earthed.

### Commissioning

Check water is hot enough to activate the low temperature cut-out thermostat.

### Controls

See accessories table.

### Specification

To specify state:

Fan Convector with EC motor, in 1.2mm zinc coated steel, 660mm

high and 595mm, 895mm, 1195mm, 1495mm or 1795mm wide.

With variable heat output controller. As Smith's Caspian UV 60, 90, 120, 150, 180.

## Technical Data

### Heat output - EC

Model Reference	Fan Speed	Control Voltage VDC	40°C MWT	45°C MWT	50°C MWT	55°C MWT	60°C MWT	65°C MWT	70°C MWT	75°C MWT	80°C MWT
EC 60	Low	3.8	0.85	1.20	1.55	1.96	2.37	2.78	3.19	3.61	4.02
	Mid	4.9	1.13	1.62	2.10	2.58	3.06	3.55	4.03	4.51	5.00
	High	6.4	1.47	2.05	2.63	3.21	3.79	4.36	4.94	5.52	6.10
EC 90	Low	3.2	1.98	2.55	3.11	3.67	4.24	4.80	5.37	5.93	6.50
	Mid	4.6	2.80	3.58	4.36	5.14	5.91	6.69	7.47	8.25	9.03
	High	6.1	3.68	4.65	5.62	6.59	7.55	8.52	9.49	10.46	11.42
EC 120	Low	3.1	3.03	3.61	4.19	4.78	5.36	5.94	6.53	7.11	7.69
	Mid	4.3	3.91	4.87	5.82	6.78	7.74	8.70	9.65	10.61	11.57
	High	5.5	4.84	6.00	7.17	8.33	9.49	10.66	11.82	12.99	14.15
EC 150	Low	2.9	3.59	4.57	5.55	6.53	7.51	8.49	9.47	10.45	11.44
	Mid	4.0	4.77	6.10	7.43	8.76	10.08	11.41	12.74	14.07	15.39
	High	5.1	6.47	7.71	8.96	10.21	11.45	12.70	13.94	15.19	16.43
EC 180	Low	2.8	4.69	5.92	7.15	8.39	9.62	10.85	12.08	13.31	14.55
	Mid	3.9	4.93	7.15	9.38	11.60	13.82	16.05	18.27	20.49	22.72
	High	4.9	7.90	9.74	11.58	13.42	15.27	17.11	18.95	20.79	22.63

Model Reference	Fan Speed	Air Volume (m³/h)	Air Volume (l/s)	Specific Fan Power w/l/s	Power Consumption (W)	NR in typical room*	Hydraulic Resistance (KPA)	Nominal Weight (KG)	Water Capacity (L)
EC 60	Low	201.00	55.90	0.14	8.00	34.00	1.38	23.00	0.92
	Mid	290.50	80.75	0.26	21.00	41.50	1.69		
	High	380.00	105.60	0.32	34.00	49.50	2.00		
EC 90	Low	297.00	80.75	0.20	16.00	34.00	4.70	36.00	1.50
	Mid	450.50	124.38	0.34	42.00	41.50	5.85		
	High	604.00	168.00	0.40	68.00	49.97	7.00		
EC 120	Low	419.30	116.50	0.14	16.00	34.00	17.78	45.00	2.08
	Mid	549.65	152.68	0.26	40.00	42.00	20.59		
	High	680.00	188.89	0.34	64.00	49.96	23.40		
EC 150	Low	459.80	127.72	0.17	22.00	34.70	22.23	60.00	2.58
	Mid	598.10	166.14	0.35	59.00	41.50	29.46		
	High	736.40	205.56	0.47	96.00	49.38	36.69		
EC 180	Low	542.00	150.56	0.19	29.00	34.90	47.83	78.00	3.18
	Mid	690.00	191.67	0.40	78.50	41.50	60.76		
	High	838.00	232.78	0.55	128.00	49.00	73.70		

\*a typical room is taken as a room with a volume of 173m³ and a reverberation time of 0.8 seconds at 500 Hz with one unit installed, situated against a wall or ceiling (radiating noise in a quartersphere). No allowance is made for attenuation provided by ceilings, enclosures or ductwork. Outputs based upon testing at EN442: 2014 using mean water temperature and an entering air temperature of 20°C with a 10°C temperature drop between flow and return.

### Correction factors

Mean Water Temp °C	45 - 80				
Water Temperature drop °C	5	10	15	20	
Entering Air Temperature °C	<b>15</b>	1.13	1.10	1.07	1.05
	<b>18</b>	1.08	1.05	1.02	0.99
	<b>20</b>	1.04	1.00	0.95	0.89
	<b>25</b>	0.93	0.91	0.89	0.86

### How to calculate Mean Water Temperature

$$\text{Mean water temperature } (\Delta T) = \left[ \frac{\text{Flow temperature} + \text{Return temperature}}{2} \right]$$

Factors are approximate data based upon a standard coil.

## Ordering Guide

Model	Packed Wt (kg)	Product Codes
CASPIAN UV 60 EC	23	HPCA20001
CASPIAN UV 90 EC	36	HPCA20002
CASPIAN UV 120 EC	45	HPCA20003
CASPIAN UV 150 EC	60	HPCA20004
CASPIAN UV 180 EC	78	HPCA20005

## Mounting Options

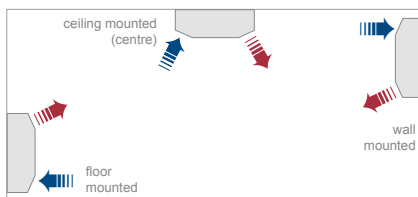

## Dimensions

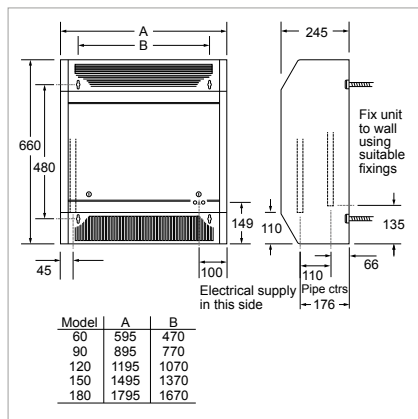

Plinths	Product Codes	
	100mm	150mm
CASPIAN UV/LST 60 PLINTH BLACK	HACA33106	HACA33097
CASPIAN UV/LST 90 PLINTH BLACK	HACA33107	HACA33098
CASPIAN UV/LST 120 PLINTH BLACK	HACA33108	HACA33099
CASPIAN UV/LST 150 PLINTH BLACK	HACA33109	HACA33100
CASPIAN UV/LST 180 PLINTH BLACK	HACA33110	HACA33101
CASPIAN UV/LST 60 PLINTH WHITE	HACA33111	HACA33006
CASPIAN UV/LST 90 PLINTH WHITE	HACA33112	HACA33007
CASPIAN UV/LST 120 PLINTH WHITE	HACA33113	HACA33008
CASPIAN UV/LST 150 PLINTH WHITE	HACA33114	HACA33009
CASPIAN UV/LST 180 PLINTH WHITE	HACA33115	HACA33010

Accessories	Product Codes
PENCIL PROOF GRILLE INSERT (PAIR TO SUIT FF, SL & UV 60)	HACA33069
PENCIL PROOF GRILLE INSERT (PAIR TO SUIT FF, SL & UV 90)	HACA33070
PENCIL PROOF GRILLE INSERT (PAIR TO SUIT FF, SL & UV 120)	HACA33071
PENCIL PROOF GRILLE INSERT (PAIR TO SUIT FF, SL & UV 150)	HACA33072
PENCIL PROOF GRILLE INSERT (PAIR TO SUIT FF, SL & UV 180)	HACA33073
FLEXIBLE HOSES 22MM PAIR	HAGA95003
ROOM THERMOSTAT HARD WIRED	HAGA95001
ROOM THERMOSTAT TAMPER PROOF	HAGA95004
CASPIAN PROPORTIONAL HEAT OUTPUT CONTROLLER 15°-25° INTEGRAL (EC)	HACA33005
CASPIAN PROPORTIONAL HEAT OUTPUT CONTROLLER 15°-25° REMOTE SENSOR (EC)	HACA33037
CASPIAN PROPORTIONAL HEAT OUTPUT CONTROLLER 11°-21° INTEGRAL (EC)	HACA33117
CASPIAN PROPORTIONAL HEAT OUTPUT CONTROLLER 11°-21° REMOTE SENSOR (EC)	HACA33118
BLANK CONFIGURABLE PROPORTIONAL HEAT OUTPUT CONTROLLER (PROGRAMMED AT FACTORY)	HACA33126
CASPIAN ADJUSTABLE LOW TEMPERATURE CUT-OUT	HACA33001
CASPIAN EXTERNAL CONTROL HARNESS (EC)	HACA33004
CASPIAN EC LINKING KIT (MASTER/SLAVE)	HACA33068
CASPIAN REMOTE SWITCHING ON/OFF RELAY (24V AC COIL)	HACA33127
CASPIAN EC THERMOSTAT (T1) & AUTO-SPEED CONTROL (T2) C/W CIRCUIT BOARD	HACA33039
CASPIAN THERMOSTAT (T1) (EC LOW LEVEL)	HACA33002
CASPIAN EC AUTO-SPEED CONTROL (T2) C/W CIRCUIT BOARD	HACA33038