



INSTALLATION AND OPERATION INSTRUCTIONS

EN

Smith's ENERGY SAVING

ES2

ES2 ADAPT

#ThinkSmiths

1 Declaration of conformity

We Taco Italia S.r.l. declare under our sole responsibility that the family of products ENERGY SAVING to which this declaration relates are in conformity with the Council Directives on the approximations of the laws of the EC Member State relating to:

- **EMCD Directive** (2014/30/EU)
Standard used: EN 61000-3-2:2014, EN 61000-3-3:2013, EN 55014-1:2006, EN 55014-2:1997 (including amendments)
- **LVD Directive** (2014/35/EU)
Standard used: EN 62233:2008, EN 60335-1:2012, EN 60335-2-51:2003 (including amendments)
- **ErP Directive** (2009/125/EC-2012/27/EU)
Commission Regulations n. 641/2009 and n. 622/2012
Applies only to circulators marked with the energy efficiency index EEI. See the pump nameplate.
Standard used: EN16297-1:2012 and EN16297-2:2012
- **RoHS II Directive** (2011/65/EU)

Sandriago, 20th April 2016



Luca Bolcati
General Manager and Managing Director

Person authorised to compile technical file and empowered to sign the EC declaration of Conformity.

2 Contents

1	Declaration of conformity	2
2	Contents.....	3
3	Indication of instructions	4
4	Important safety and installation instructions	5
5	Field of application.....	8
5.1	Types of system	8
5.2	Pumped liquids.....	8
6	Product information	9
6.1	Description of the product.....	9
6.2	Type key.....	9
6.3	Name plate.....	10
6.4	Components.....	10
6.5	Supply	10
6.6	Technical data.....	11
7	Installation at Site	12
7.1	Installation	12
7.2	Permissible installation positions	13
7.3	Motor housing regulation	13
7.4	Insulation of pump housing.....	14
8	Electric connection.....	15
9	Commissioning	16
9.1	Start-up of the circulator	16
9.2	Operating elements.....	16
9.3	Mode of operation	17
9.4	Automatic detection of the presence of air - Vent system.	18
10	Circulator setting	19
11	Performance curves.....	20
11.1	Performance curves - ES2 60.....	20
11.2	Performance curves - ES2 ADAPT 60	20
12	Maintenance.....	21
13	Faults, causes and remedies.....	21
13.1	Fault finding table.....	21
13.2	Unlocking procedure	22
14	Warranty.....	22
15	Disposal.....	22

These instructions include information necessary to assemble and use the product correctly. Besides respecting the general safety regulations, it is necessary to observe all points specifically and specially marked.

3 Indication of instructions

This manual contains information and prescriptions marked by the following symbols.



The inobservance of the safety provisions marked by the symbol “caution: hazard” may endanger the safety of people.



The inobservance of the safety provisions marked by the symbol “caution: electricity” may endanger the safety of people, as well as the integrity of things.

CAUTION

The inobservance of the safety provisions marked by the word “CAUTION” may endanger the integrity and functionality of the equipment and of the machines.

The Quick Guide contains following warning symbols.



The circulators are not to be used to transfer flammable liquids such as petroleum, oils, gas oil or similar liquids.



The circulators are not to be used to transfer aggressive liquids, such as acids and sea water.



CAUTION
The removal of the screws can cause the output of hot fluids under high pressure from heating system. Drain the system or close the isolating valves.



CAUTION
High temperature surface. Take utmost care to prevent people from getting in contact with the hot surfaces of the circulator.

4 Important safety and installation instructions

Prior to installation, read these installation and operating instructions. The installation and operation should also be in accordance with national regulations and accepted codes of good practice.



This appliance can be used by children aged from 8 years and above and persons with reduced physical, sensory or mental capabilities or lack of experience and knowledge, only if they have been given supervision or instruction concerning use of the appliance in a safe way and understand the hazards involved. Children shall not play with the appliance. Cleaning and user maintenance shall not be made by children without supervision.



To guard against injury, basic safety precautions should be observed, including the following:

1. Read and follow all safety instructions and all the important notices on the appliance before installing, using and maintaining the circulator. Failure to do so may cause personal injury or damage to the circulator or installation.



2. Always disconnect electrical supply before putting on or taking off parts and whilst the equipment is being installed, maintained or handled. Never work with bare feet and/or with wet hands.



3. To avoid possible electric shock, special care should be taken since water is used with electrical equipment. Carefully examine the circulator before and after installation. Do not operate the circulator if it has a damaged supply cord or enclosure, or if it is malfunctioning or it is dropped or damaged in any manner. Inspect the circulator periodically.

The circulator should not be electrically supplied if there is water on parts not intended to be wet.



4. Risk of scalding.

To avoid injury before any servicing operation wait until the water has cooled inside the circulator. Do not touch the fluid or the circulator when temperature is higher than 60°C.

5. Improper use

This is a circulator to be used in heating systems and for the circulation of clean water without abrasive particles. This is not a submersible pump.

Do not use this circulator:



- With liquids other than water (e.g. flammable liquids, etc.) (EN60335-2-51);
- For handling drinkable water or food related liquids;
- For the circulation of domestic water;
- In locations where special condition prevail, such as the presence of a corrosive or explosive atmosphere (dust, vapor or gas) (EN60335-2-51);
- For other than intended use.

Never run the circulator dry. The circulator must always be fully filled with water when operating.

6. Installation

The circulator must be mounted in a stable/fixed position in a dry, well ventilated, frost-free, waterproof and protected place, with sufficient ventilation around it. Make sure that the circulator is securely and correctly installed before operating it and that there is enough room around it for maintenance operations, dismantling, checking for free inspection.

The maximum ambient temperature at which the pump is to be used is 40°C (EN60335-2-51).

To avoid circulator overheating, do not place any object on the circulator itself.

7. Electric connection



IMPORTANT: Connection to the power supply must be effected by means of a fixed power cable which is fitted with a plug-type connection or an all-pole isolating switch with a minimum contact opening of 3 mm.

Electrical connection must be carried out only by a qualified electrician and in accordance with local regulations and both data on the name-plate and the appropriate diagram inside the terminal box cover.

Follow all safety standards.

Do not connect to mains supply unless circulator is fully and correctly assembled.



8. Supply cord must be selected following the requirements of EN60335-2-51 Chapter 25. Supply cord must be protected against any kind of mechanical damage (cuts, abrasion, etc.). It must not touch the pipe or the pump. (EN 60335-2-51). If the insulation of the Supply cord can come in contact with parts having a temperature exceeding 70°C the supply cord insulation must be protected, for example, by insulating sleeving having an appropriate temperature rating. (EN60335-2-51) .



9. Connect circulators only to a mains supply protected by a Residual Current Device (RCD or Ground-Fault Circuit-Interrupter) with a rated residual operating current not exceeding 30mA.

10. Prior to any modification being made to the equipment, it must be agreed with and authorised by the manufacturer. Original spare parts and accessories authorised by the manufacturer are integral part contributing to the safety of the equipment and of the machines. The use of non original components or accessories may endanger the safety and causes the termination of the

warranty. Safe operation is only assured for the applications and conditions described in → **5 Field of application** of this manual.

Non-observance of the safety instructions results in the loss of any claims to damages.



The indicated limit values are binding and cannot be exceeded for any reason whatsoever.

KEEP THESE INSTRUCTIONS FOR FUTURE REFERENCE.

5 Field of application

5.1 Types of system

Models	Uses
ES2	<p>Circulation of water/liquids in hot water heating systems for all kinds and in similar systems:</p> <ul style="list-style-type: none"> • One-pipe systems • Two-pipe systems • Systems with constant or variable flows • Underfloor heating systems • Boiler or primary circuit • Storage tank circuit
ES2 ADAPT	<p>Circulation of water/liquids in hot water heating systems and in renewable energy solar thermal systems:</p> <ul style="list-style-type: none"> • Solar thermal systems • One-pipe systems • Two-pipe systems • Systems with constant or variable flows • Underfloor heating systems • Boiler or primary circuit • Storage tank circuit

5.2 Pumped liquids

For use with clean liquids, that are not aggressive or explosive and not containing solid particles, fibres or mineral oils.

In heating systems:

Water for heating according to VDI 2035.

Mixtures of water and glycol with glycol percentages not greater than 30%.

In domestic hot water circulation systems, max. 38°d water hardness.

Any other use is regarded as incorrect use. For the use with other fluids, manufacturer's authorisation is required.



- The circulators are not to be used to transfer flammable liquids such as gasoline, oils, gas oil or similar liquids.
- The circulators must never be used in refrigeration systems, air conditioning systems and similar installations.

6 Product information

6.1 Description of the product

The ENERGY SAVING are a range of innovative wet rotor circulators with an integrated frequency converter (INVERTER). ENERGY SAVING circulators combine an advanced hydraulic system, a high efficiency motor, an intuitive electronic control and an operating software that allows the pump to perfectly adapt to the various operating conditions and the actual needs of the system.

The motor with electronic control module is mounted on the pump housing by four screws. The criteria for differential pressure control depend on the set operating mode. In all operating modes, the circulator adapts to the different loads of the system.

ENERGY SAVING provides excellent benefits:

1. Energy saving
2. Compact design
3. Ideal performance
4. Easy installation and adjustment

The ENERGY SAVING circulator range is available in the following versions:

ES2	Standard version with operating modes P, C and min-max. Pump housing available in cast iron, plastic composite material (C) and plastic composite material with air separator (C A)
ES2 ADAPT	Premium version with operating modes activeADAPT, P, C and min-max. Pump housing available in cast iron.

6.2 Type key

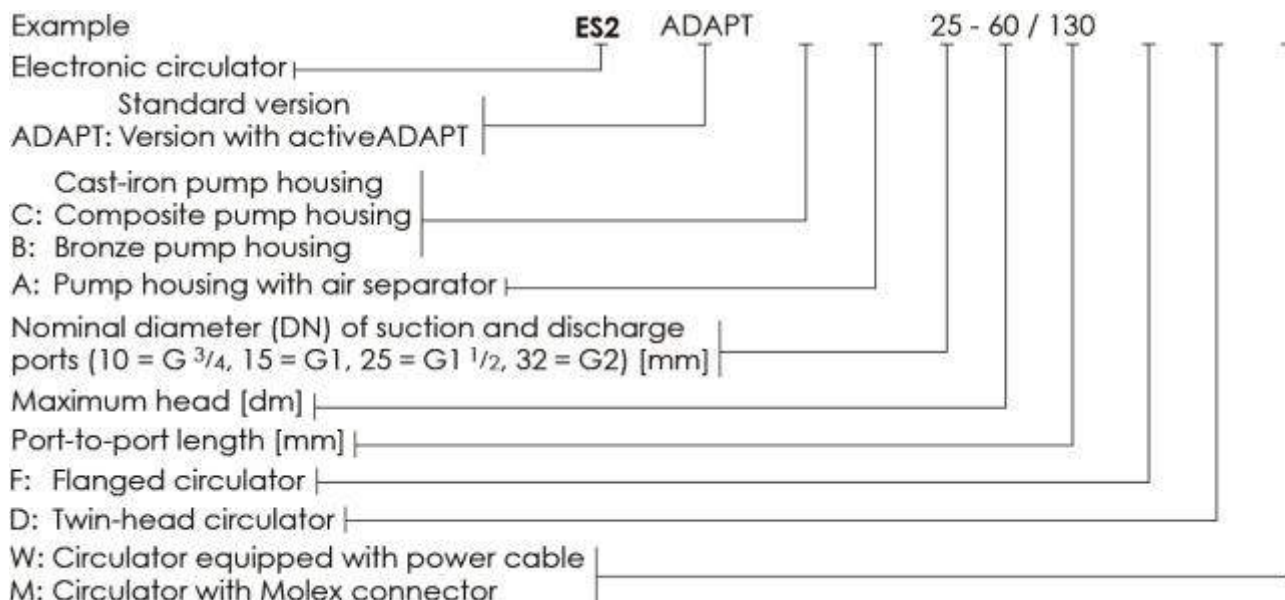

6.3 Name plate



- 1 Type
- 2 Code
- 3 Input power P_1 [W] / Input current I_1 [A] / System pressure [MPa]
- 4 Voltage, frequency
- 5 Temperature class / Protection class
- 6 Energy Efficiency Index (EEI)
- 7 CE mark / Appliance class / Quality mark

Fig. 6.1: Name plate (example)

6.4 Components



Fig. 6.2: Exploded view

A	Pump housing
B	Impeller and bearing plate
C	Rotor
D	Can

E	Stator
F	Electronics
G	Motor housing
H	Front cover

6.5 Supply

- Complete circulator.
- Two flat seals in EPDM.
- Thermal insulation shells in EPP (supplied as standard only for mod. ES2 ADAPT)
- Instructions for assembly, use and maintenance.

6.6 Technical data

Power supply	1x230 V \pm 10%, 50 Hz	
Adjustment of the rotation speed	Manual by selector	
Motor protection	Not required	
Insulation class	H	
Protection class	IP 44	
Appliance class	II	
Ambient temperature	from +2°C to +40°C	
Allowed liquid temperature	ES2	from +2°C to +95°C
	ES2 ADAPT	from +2°C to +110°C
Maximum relative humidity	\leq 95%	
Maximum operating pressure	ES2	0,6 MPa (6 bar)
	ES2 ADAPT	1,0 MPa (10 bar)
Minimum pressure on the intake opening¹	Minimum pressure	Liquid temperature
	0.03 MPa (0.3 bar)	50°C
	0.10 MPa (1.0 bar)	95°C
	0.15 MPa (1.5 bar)	110°C
Sound pressure level	< 43 dB(A)	
EMC (electromagnetic compatibility)	EN 61000-3-2 / EN 61000-3-3 EN 55014-1 / EN55014-2	
Specific EEI values ²	ES2 60	EEI \leq 0,20 - Part 2
	ES2 ADAPT 60	

To avoid condensation in the motor and the electronics the temperature of the pumped liquid must always be greater than the ambient temperature.

	Ambient temperature	Liquid temperature	
	[°C]	Min. [°C]	Max. [°C]
ES2	0	2	95
	10	10	95
	20	20	95
	30	30	95
	35	35	90
	40	40	70
ES2 ADAPT	0	2	110
	10	10	110
	20	20	110
	30	30	110
	35	35	90
	40	40	70

¹ To avoid cavitation noise, minimum pressure values on the intake opening must be strictly respected.

² The benchmark for most efficient circulators is EEI \leq 0,20.

7 Installation at Site



Installation and service by qualified personnel only!

7.1 Installation

The circulator must be mounted in a stable/fixed position in a dry, well ventilated, frost-free, waterproof and protected place, with sufficient ventilation around it.

Assemble the circulator only after having ended all welding and brazing works on the hosing.

Before installing the circulator, make sure that the internal part of the tubes is clean.

Install the circulator in an accessible place for future checks and disassembly procedures. Foresee enough space for inspections and disassembling.

Foresee isolating valves at intake and output (before and after the circulator) to allow the disassembly without emptying the plant. The assembly of the interception organs must be carried out in such a way as to prevent possible water leaks from involving the terminal board.

Perform the assembly without mechanical stresses acting on the circulator.



Avoid the installation in misaligned pipe work.

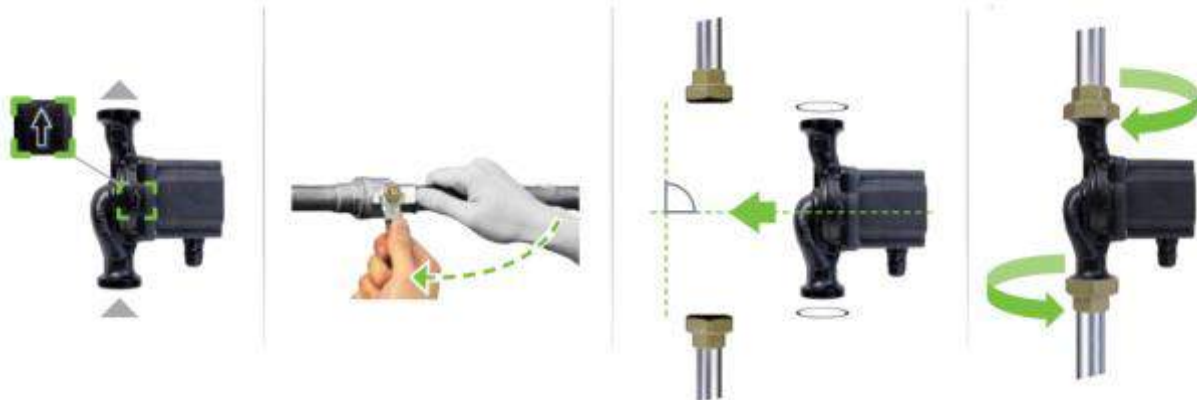

Fig. 7.1: Mounting procedure.

The direction of the water flow is indicated by the arrow on the pump housing, as shown in Fig. 7.1.

1. Check that both isolating valves are closed.
2. Install the circulator with the motor shaft in horizontal position. Connect the piping without transmitting any stresses and strains.
3. Accurately insert the two gaskets supplied.
4. Establish a screwed connection between circulator and piping.
5. Tighten the screwed connection hand with an assembly tool (e.g. pipe wrench).

Thread	Pump housing material	Tightening torque
G1	Composite PA 66 GF	Max. 50 Nm
G1	Cast Iron EN-GJL-200	Max. 85 Nm
G1½	Cast Iron EN-GJL-200	Max. 125 Nm
G2	Cast Iron EN-GJL-200	Max. 165 Nm

7.2 Permissible installation positions



Install the circulator with horizontal motor shaft axis (Fig. 7.2).



Fig. 7.2: Permissible installation positions

7.3 Motor housing regulation



Fig. 7.3: Motor housing positions

The motor body can be rotated in the positions shown in Fig. 7.3.



Take utmost care to prevent people from getting in contact with the hot surfaces of the circulator. Drain the system or close the isolating valves on either side of the pump before the screws are removed. The pumped liquid may be scalding hot and under high pressure.

CAUTION

Pay attention not to damage the seal of the pump housing.



Fig. 7.4: Changing the motor body position

Procedure (Fig. 7.4):

1. Slacken and remove the four screws M5 holding the motor.
2. Turn the motor to the desired position without extracting it from the pump housing.
3. Insert and tighten the pump housing screws (The tightening torque of the screws of the pump housing must correspond to a value of 3.3 ± 0.5 Nm).

7.4 Insulation of pump housing



Fig. 7.5: Insulation of pump housing

The heat loss from the pump and pipework can be reduced by insulating the pump housing and the pipe with the thermal insulation shells supplied with the circulator (supplied as standard only with model ES2 ADAPT) → Fig. 7.5.

The thermal insulation shells can be ordered separately.

CAUTION

Do not insulate the control box or cover the control panel.

8 Electric connection



The electric connection has to be performed by a qualified electrician in compliance with the national regulations. **Follow the safety regulations and installation regulations of your country.**



Connection to the power supply must be carried out in compliance with the standards via a fixed power cable which is fitted with a plug-type connection or an all-pole isolating switch with a minimum contact opening of 3 mm.

The circulator belongs to class II and therefore grounding is not necessary. The circulator does not require any external protection of the motor. Compare the frequency and the voltage of the mains with the rating data. All electric information concerning the circulator is on the signaling plate. The connection cord must be laid in such a way as it cannot come in contact with the hosing or the motor body. In case of use of the circulator with fluids at a temperature higher than 70 °C, use a connection cord resistant to high temperatures.

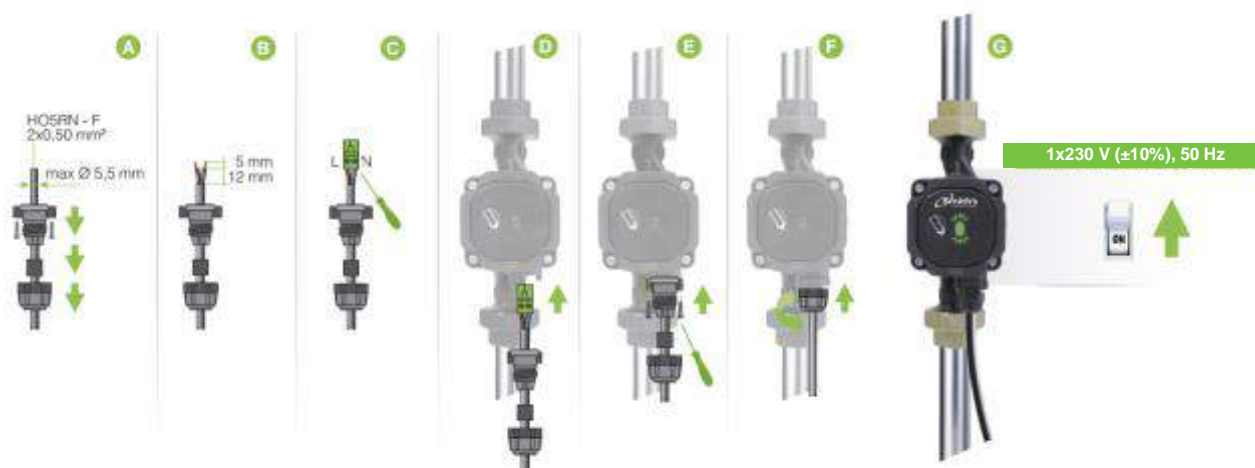

Fig. 8.1: Electric connection

1. Connect the power supply conductors to the terminals according to the diagram given in Fig. 8.1, from A to C.
2. Insert the terminal board in the proper seat, connecting the blue wire (neutral) with letter N and the black/brown wire (phase) with letter L. (Fig. 8.1.D).
3. Screw the two screws (Fig. 8.1.E - The tightening torque of the screws must correspond to a maximum value of 0,3 Nm).
4. Tighten the sealing nuts to the fairlead (Fig. 8.1.F - The tightening torque must correspond to a maximum value of 2 Nm).
5. The LED light, if lighted, indicates that the power supply is present. (Fig. 8.1.G).

To ensure drip protection and strain relief at the PG screwed connection, a connected load with an adequate outer diameter is necessary (e.g. H05VV-F 2x1, H05RN-F 2x1, H05VV-F 3x1 o H05RN-F 3x0,75).

9 Commissioning

9.1 Start-up of the circulator

CAUTION

You must avoid dry operation. Start the circulator only after having completely filled the plant.

CAUTION

Circulators with permanent magnets can not be driven in speed by means of phase control of the supply voltage.

CAUTION

Circulators driven by an electronic frequency converter have a current peak at each activation (inrush current) greater than traditional circulators (asynchronous). The activation stage of the circulator has to be size taking into account this current peak. For further details contact the manufacturer.

Activation frequency: activations/deactivations through the mains voltage $\leq 20/24$ h.

9.2 Operating elements

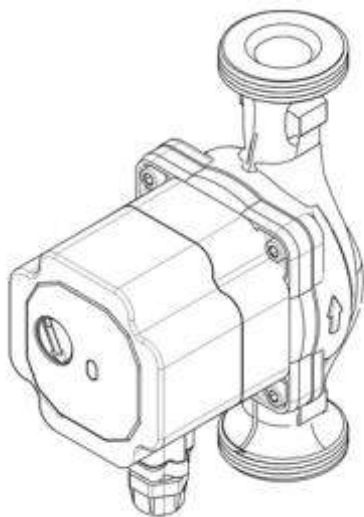
**Selector**

All settings are made using the selector on the housing front.
The selector can be adjusted in a continuous way with a rotation angle of 270° .
The arrow on the selector indicates the operating mode chosen.







LED light

The LED light on the front advises the commissioning/fault of the circulator.
Every operating mode is characterised by a fixed light of different colour.
After a change of operating mode, the LED pulses 5 times. The pulse will be a change of brightness intensity of the LED light.

Fig. 9.1: Selector and LED light

9.3 Mode of operation

An LED provides information about the operation status of the circulator.

LED	COLOR	DESCRIPTION
 activeADAPT	Violet	<p>activeADAPT mode</p> <p>The activeADAPT mode enables the circulator to actively adapt its performance to the demands of the system during short control intervals inside a defined control area.</p> <ul style="list-style-type: none"> • Improves the hydraulic balance of the system • Ensures optimum performance during partial load periods • Enables quick installation
	Green	<p>P mode ($\Delta p-v$) – Proportional differential pressure</p> <p>The circulator head is proportionally reduced at falling water demand and increased at rising water demand.</p> <p>The circulator head is proportionally reduced with decreasing of the heat demand from the heating system (flow rate decrease) and is proportionally increased with increasing demand of the heat demand from the heating system (flow rate increase).</p>
	Orange	<p>C mode ($\Delta p-c$) - Constant differential pressure</p> <p>The circulator maintains a constant pressure level (head) irrespectively of the heat demand required from the heating system (flow rate).</p>
	Blue	<p>min-max mode– Fixed speed</p> <p>The circulator maintains a fixed speed irrespectively of the heat demand from the heating system (flow rate). The speed regulation is done by positioning the selector in a gradual manner at any point between the Min and Max positions. Should this performance be insufficient, progressively increase the set value. Should this performance be excessive or should noise arise due to the speed of the pumped fluid, progressively reduce the calibration.</p>
	Flashing white	<p>Automatic detection of the presence of air. Proceed with the vent routine</p>
	Red	<p>Fault or malfunction → 13 Faults, causes and remedies</p>

9.4 Automatic detection of the presence of air - Vent system.



Fig. 9.2: Filling and venting of heating systems

Fill and bleed the system correctly.

The circulator can be noisy at start due to the presence of air. Such noise should stop after few minutes of operation. The pump rotor chamber normally bleeds automatically after a short time in operation.

The circulator is equipped with a special software system that detects the presence of excess air within the heating system. The LED shows the presence of air in the hydraulic circuit by flashing and performing a rapid succession of WHITE colour.

Following the light signal, it's possible to easily vent the heating system as follows:

1. Open the air vent valve in the hydraulic circuit above the circulator;
2. set the circulator to MAX position (maximum performance setting);
3. let the circulator run for a short period, according to the construction and the plant size;
4. once vented the system - the guide light (LED) stops blinking and the possible noise stops - set the circulator as indicated in **Par.10 Circulator setting**

Repeat the procedure if necessary.

CAUTION

The system cannot be drained by using the circulator.

With solar thermal systems, fill the system with mixtures prepared for that application. The circulator cannot be used to mix the fluids in the system.



Do not touch the fluid or the circulator when the temperature is greater than 60 °C. Hazard of scalding by simple contact.

10 Circulator setting

Modify the performance of the circulator (head) as needed by rotating the selector using a flat screwdriver, as given in the following table. The selection of the right functioning curve depends on the characteristics of the heating system in question and the actual heat demand.

LED	MODEL	
	ES2 ADAPT	ES2
activeADAPT	 activeADAPT *	-
Δ^p	 Lowest proportional curve P1	 Lowest proportional curve P1 *
	 Intermediate proportional curve P2	 Highest proportional curve P2
	 Highest proportional curve P3	-
Δ^c	 Lowest constant curve CI	 Lowest constant curve CI
	 Intermediate constant curve CII	 Highest constant curve CII
	 Highest constant curve CIII	-
min - max	 Fixed speed curves min - max	 Fixed speed curves min - max

* Factory setting

11 Performance curves

11.1 Performance curves - ES2 60

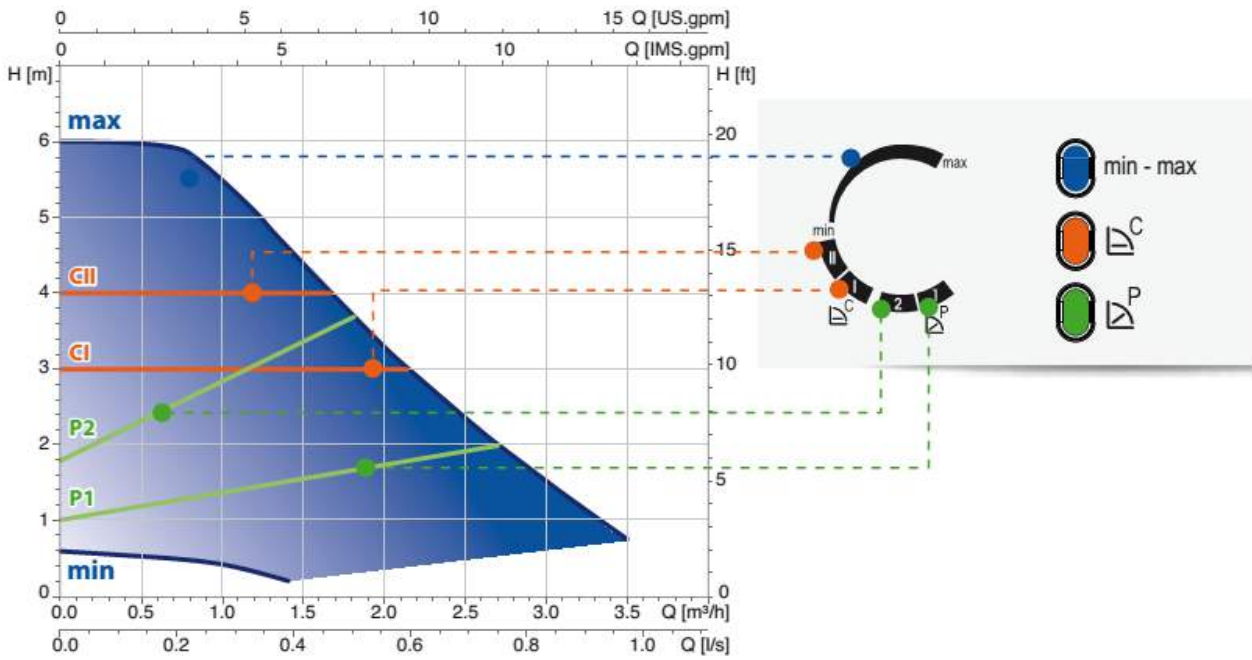

11.2 Performance curves - ES2 ADAPT 60

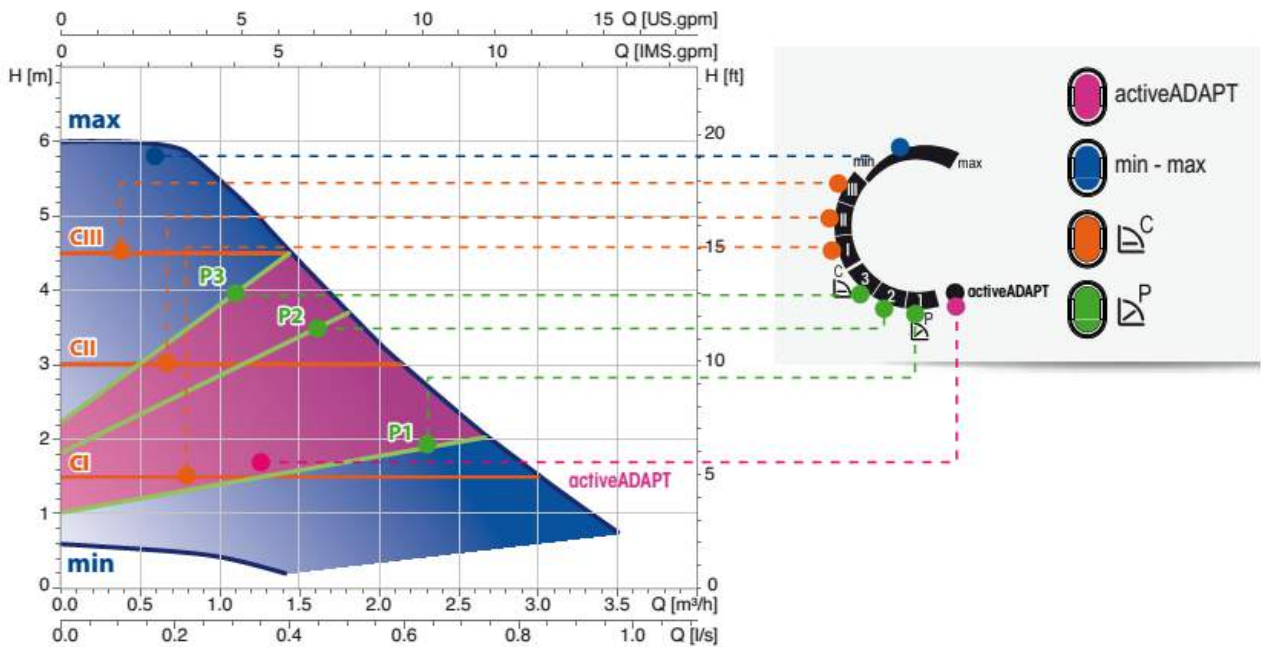

12 Maintenance

The circulator does not require any special maintenance during operation. Motor bearings are lubricated by the pumped liquid.



Before each maintenance intervention, disconnect power supply and wait for the circulator to cool.

13 Faults, causes and remedies

13.1 Fault finding table

FAULTS	CONTROL PANEL	CAUSES	REMEDIES
The circulator is noisy	LED on	Suction pressure is insufficient - cavitation	Increase the system suction pressure within the permissible range.
	LED on	Presence of foreign bodies in the impeller	Disassemble the motor and clean the impeller
Loud noises of water circulation	Flashing white LED	Air in the system	Vent the system (→ 9.4 Automatic detection of the presence of air - Vent system.)
	LED on	The flow is too high	Reduce the rotation speed (→ 10 Circulator setting)
Circulator is not running although the electrical power supply is switched on	LED off	Lack of power supply	Verify voltage value of the electric plant Verify the connection of the motor
		One fuse in the installation is blown	Verify the fuses of the plant
	The circulator is defective	Replace the pump.	
	LED red	Overheating	Let the pump cool down for some minutes. Then try to re-start it. Verify that the water and ambient temperature are within the indicated temperature ranges. Disassemble the motor and clean the impeller. Should you fail to eliminate the cause of the malfunction, refer to the Distributor or nearest Service Centre. If this doesn't succeed (→ 13.2)
		The rotor is blocked	
	Insufficient supply voltage	Verify that the power supply matches the data on the name plate.	
Building does not get warm.	LED on	The circulator performance is too low	Increase the suction head (→ 10 Circulator setting)

Should you fail to eliminate the cause of the malfunction, refer to the Distributor or nearest Service Center.

13.2 Unlocking procedure

A red light in the LED indicates a locking.

Turn the selector to the position **max**, disconnect and connect power supply to start the automatic release process.

The circulator operates 100 attempts to restart (process lasts approximately 15 minutes).

Every restart is signalled by a short flash of LED light. If the locking is not removed through the automatic release process after 100 attempts to restart the circulator, it goes into standby and the LED remains red. In this case follow the manual procedure described in the next steps:

during any attempt, the red LED light keeps blinking; after that the circulator tries again to start. If the locking is not removed through the automatic release process (the warning light returns to be red), it is necessary to perform the manual procedure described in the next steps:

Disconnect power supply - the warning light switches off.

Close the interception organs upstream and downstream of the circulator and let it cool.

Disassemble the motor and clean the impeller.

1. Disconnect power supply - the warning light switches off.
2. Close both isolating valves and allow cooling. If there are no shut-off devices, drain the system so that the fluid level is beneath that of the circulator.
3. Carefully pull the rotor/impeller
4. Remove impurities and deposits with appropriate agents.
5. Reinsert the rotor/impeller
6. Set the selector on the wished position.
7. Connect power supply.

If the circulator doesn't run → **13 Faults, causes and remedies.**



**With high fluid temperatures and pressures there is the risk of burning.
Hazard of scalding by simple contact.**

14 Warranty

The Smith's 5 year warranty covers manufacturing or material defects on domestic heating circulators. It does not cover installation or system design faults, damaged packaging or pumps seized due to system deposits. Proof of purchase required for administrating warranty claims.

15 Disposal

The correct disposal and recycling of this product will prevent damage to the environment and risks to human health.

1. Use public or private disposal organisations when disposing of all or part of the product.
2. For information about proper disposal, it is necessary to ask to the city administration, the authorised office or the retailers of the product.

Reserved right of modification



For product information, customer services or sales support call us on
01245 324900

sales@smithsep.co.uk

Smith's Environmental Products Ltd

Backall Industrial Estate, South Woodham Ferris, Chelmsford, Essex CM3 5UW

www.SmithsEP.co.uk



#ThinkSmiths