

# Zip Hydroboil Econoboil

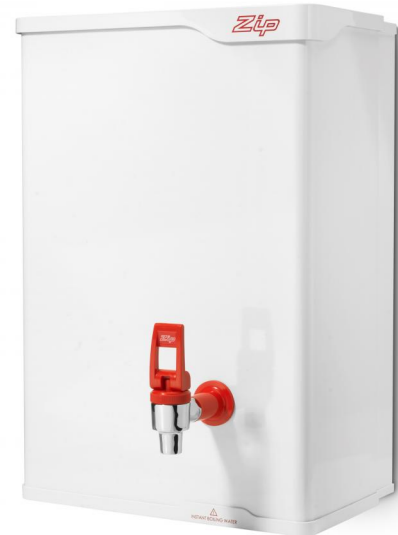

## Instant on-wall boiling water

The EconoBoil is a thermostatically controlled instant boiling water system for settings where affordable reliability is required. The 5 litre Econoboil delivers boiling water at a constant temperature from a smart, compact unit.



MODEL	TANK SIZE (litres)	HEAT UP TIME (INLET 15°C)	HEAT UP TIME (INLET 10°C)	NOMINAL POWER RATING KW	DIMENSIONS W X D X H	FILLED WEIGHT
405542	5	16mins	17mins	2.2 kW @ 230V AC	329mm x 201mm x 473mm	16.5kg

## Features and benefits

### Convenience

The Hydroboil range delivers reliable boiling water instantly, saving time and helping to increase workplace productivity.

### Space saving

Wall-mounted units save much-needed counter-top and under-counter space.

### Easy and safe to use

Simple controls and a range of safety features give you complete peace of mind.

### Energy efficient

Steam-Heat-Boost technology saves energy by recycling steam to pre-heat incoming cold water – making boiling quicker and less costly.

### Wide range

With capacities ranging from 1.5 to 40 litres, there is a model for every situation.

## Product detail

---

### Specification type

Product code	405542 (HS505)
Product name	EconoBoil HS505 5ltr Instant on-wall boiling water heater in white
Case material	Corrosion Resistant White Enamelled Steel
Instant boiling water	Twin chamber
Control	N/A
Service Access Port	Top and bottom

---

### Capacity, weights & dimensions

Capacity	5ltrs
Unit dimension (W x D x H)	329mm x 201mm x 473mm
Product weight	16.5kg

---

### Plumbing

Wholesome cold water inlet supply required	Yes
Supply pressure range	0.07 MPa (0.7bar) - 0.5 (5bar)
Inlet pipe	1/2" BSP
Vent pipe	15mm
Vent discharge	Visible tundish or drainage board
Installation	Must comply with current water supply regulations

---

The minimum water pressure will vary if a limescale filter is installed. Please contact us to discuss your requirements.

### Electrical

Nominal power rating kw	2.2 kW @ 230V AC
Power supply 40L models	Separate 220-240V AC 50Hz ring main rated at 32A isolated by double pole isolation switch
Installation	Must comply with current IEE regulations

---

### Warranty

1 Year on-site parts and labour on site	Terms and conditions apply (visit website for more information)
---	---

---

# Technical drawings & dimensions

All dimensions in mm

All dimensions in mm

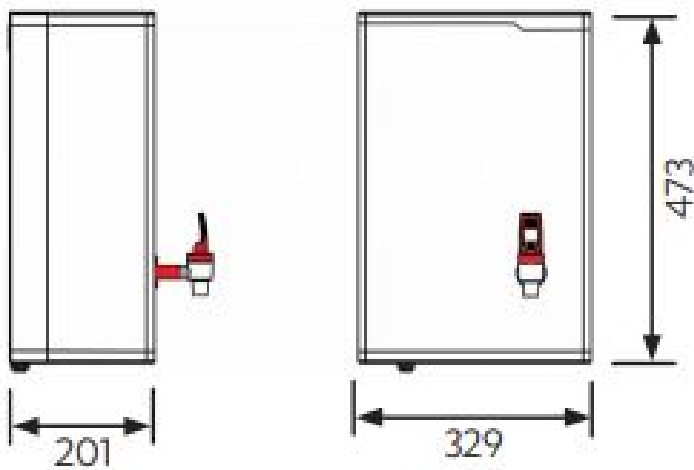
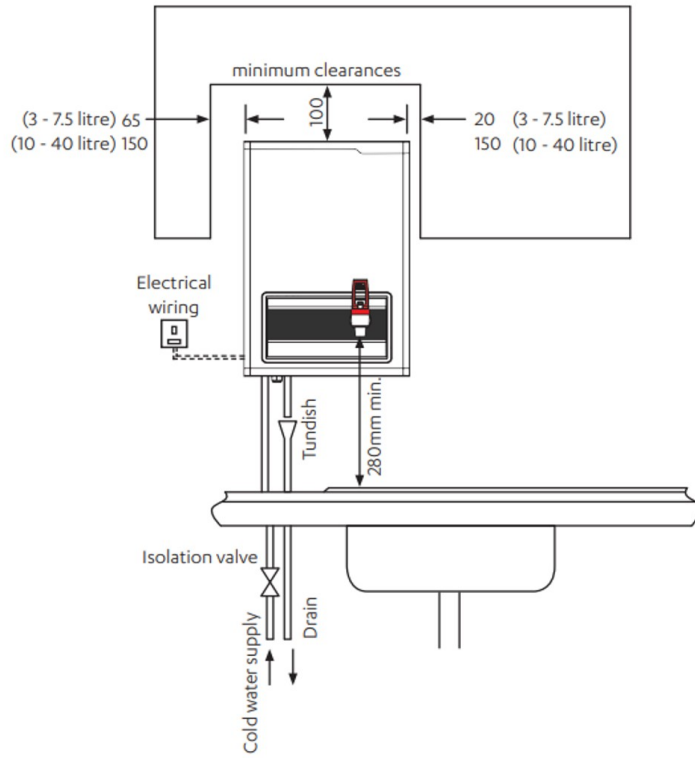

405542 5.0 litre